

UNC HEALTH EASTOWNE

EASTOWNE DRIVE
CHAPEL HILL, NC, 27560

CONDITIONAL ZONING PLAN

PROJECT NUMBER: UNH22001
DATE: DECEMBER 19, 2022

GENERAL NOTES

- EXISTING FARM POND IS TO BE DRAINED. THE RESULTING STREAMS AND PROPOSED STREAM ENHANCEMENT PROJECT DOWNSTREAM OF THE EXISTING POND DAM WILL BE SUBJECT TO A COINCIDENT 50-FOOT WIDE JORDAN RIPARIAN BUFFER AND RCD.
- STREETS AND/OR ACCESS POINTS ON EASTOWNE DRIVE MAY BE REQUIRED TO SHIFT TO ADDRESS THE FINAL INTERNAL BLOCK LAYOUT OR TO ACCOMMODATE TRANSPORTATION/TRAFFIC STUDY AND DESIGN REQUIREMENT BY NCDOT AND/OR THE TOWN. FINAL ALIGNMENTS TO BE DETERMINED WITH THE FINAL PLAN (ZCP).
- IMPROVEMENTS SHOWN ON US HWY 15-501, EASTOWNE DRIVE IN THE PROXIMITY OF THE INTERSECTIONS WITH US HWY 15-501 AND DOBBINS DRIVE ARE SUBJECT TO THE REVIEW AND APPROVAL OF NCDOT.
- STORMWATER MANAGEMENT WILL BE IN ACCORDANCE WITH THE STORMWATER MANAGEMENT NARRATIVE SUBMITTED WITH THE CONDITIONAL ZONING APPLICATION. FINAL LOCATIONS AND DESIGNS OF THE STORMWATER CONTROL MEASURES WILL BE DETERMINED WITH THE FINAL PLAN (ZCP) SUBMITTAL.
- EXISTING BUILDINGS AND SURFACE PARKING LOTS MAY REMAIN IN USE AS NEEDED DURING THE DEVELOPMENT OF THE PROJECT.
- PROPOSED CROSSINGS AND IMPACTS TO THE RCD SHOWN ON THE CONCEPTUAL PLAN ARE APPROVED AS PART OF THE CZ APPROVAL AND WILL MEET THE REQUIREMENTS OF LUMO SECTION 3.6.3-2 PERMITTED USES IN THE RCD AND SEC. 3.6.3.(G) STANDARDS FOR DEVELOPMENT IN THE RCD. DETAILED DESIGN OF THE CROSSINGS OR OTHER IMPACTS TO BE PROVIDED WITH THE FINAL PLAN (ZCP) SUBMITTAL.
- PROPOSED MULTI-USE PATH, OR GREENWAY, MAY BE CONSTRUCTED IN THE OUTER 20-FEET OF THE JORDAN RIPARIAN AND RCD BUFFERS.
- THE PROPOSED CENTER GREEN WILL BE A MINIMUM OF 60,000 SQUARE FEET, INCLUDE HANDSCAPE AND LANDSCAPE AREAS AND MAY INCLUDE UN-ENCLOSED ROOFED OR COVERED AREAS.
- PHASING OF THE DEVELOPMENT WILL BE DETERMINED DEPENDING ON THE NEEDS OF UNC HEALTHCARE. ADDITIONAL PHASE SPECIFIC TRAFFIC STUDIES MAY BE REQUIRED TO IDENTIFY PHASE SPECIFIC TRAFFIC IMPROVEMENTS REQUIRED.

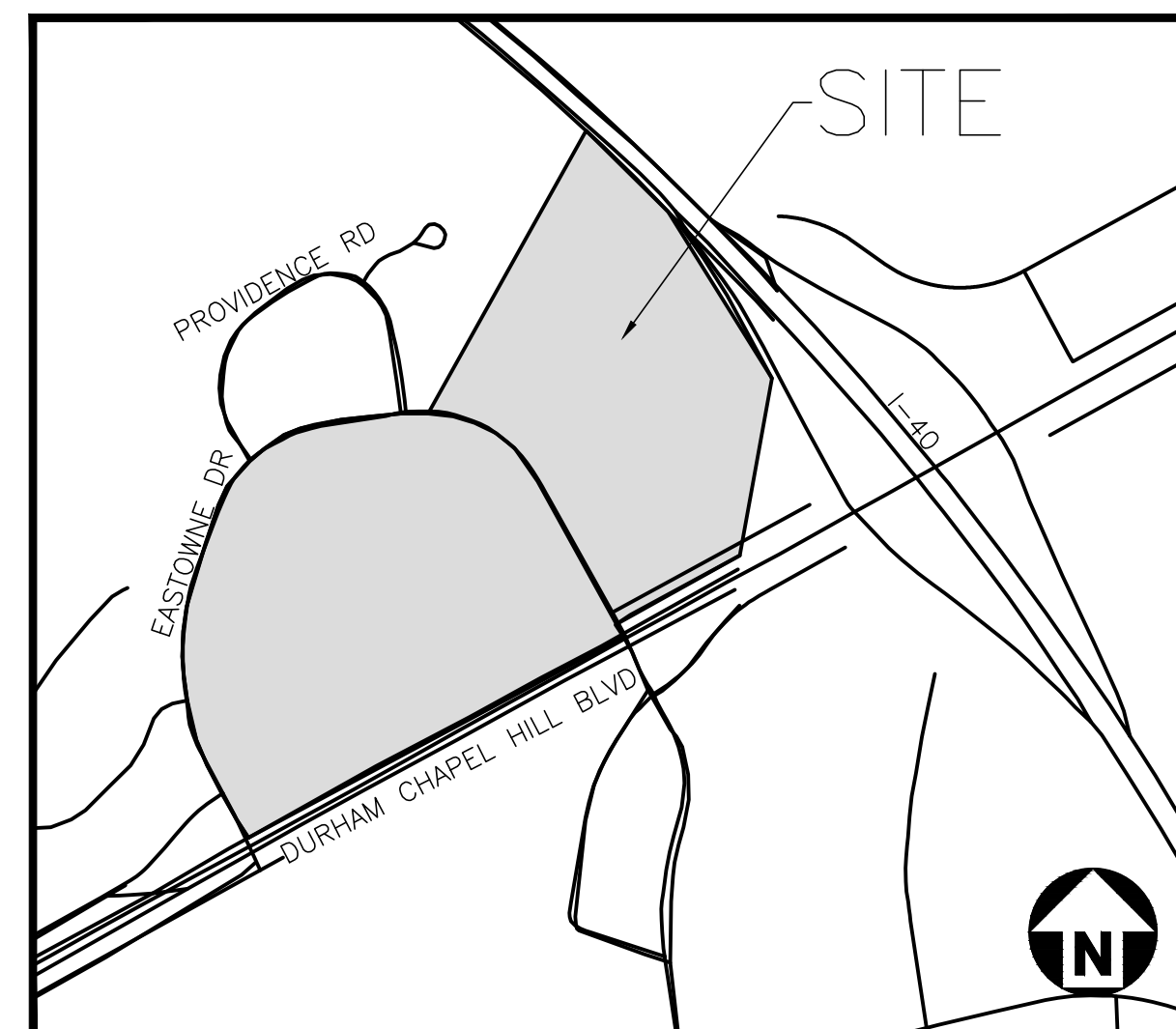

VICINITY MAP
N.T.S.

SHEET INDEX

C0.00	COVER SHEET
C1.00	EXISTING CONDITIONS
C1.01	AREA MAP
C1.02	STEEP SLOPES
C2.00	OVERALL CONCEPT PLAN
C2.01	MOB 2 CONCEPT PLAN
C3.00	STREET SECTIONS

SITE DATA

PHYSICAL ADDRESS	400 EASTOWNE DR	
OWNER	HEALTH SYSTEM PROPERTIES, LLC	
PIN	9890800195, 9890800643, 9890802764, 9890803947, 9890807564, 9890911209	
EXISTING ZONING	OI-3, OI-2, MU-OI-1	
PROPOSED ZONING	OI-3-CZ	
NET LAND AREA (SQ FT)	2,202,829	
CREDITED STREET AREA (SQ FT)	220,283	
GROSS LAND AREA (SQ FT)	2,423,112	
AREA IN RCD (SQ FT)	288,974	
AREA IN FLOODPLAIN (SQ FT)	102,752	
PROPOSED BUILDING HEIGHT (MAX)	120 FT	
FLOOR AREA		
EXISTING FLOOR AREA (SQ FT)	228,000	
FLOOR AREA TO BE REMOVED (SQ FT)	78,000	
NEW FLOOR AREA (SQ FT)	1,100,000	
TOTAL FLOOR AREA (SQ FT)	1,250,000	
MAX FAR (FA/GLA)	.566	
PROPOSED FAR (FA/GLA)	.680	
BUILDING SETBACKS	REQUIRED	PROPOSED
STREET	0'	22'
INTERIOR	0'	8'
SOLAR	0'	9'
IMPERVIOUS		
EXISTING IMPERVIOUS (SQ FT)	405,645	
EXISTING IMPERVIOUS TO BE REMOVED (SQ FT)	268,329	
NEW IMPERVIOUS	1,420,056	
TOTAL IMPERVIOUS	1,538,761 or 70% of GLA	
BUFFERS	REQUIRED	PROPOSED
15-501	20' TYPE C	30' MODIFIED
EASTOWNE DRIVE	15' TYPE B	15' MODIFIED
US 40	30' TYPE D	100' TYPE D
SIDEYARDS	15' TYPE B	15' TYPE B
PARKING		
EXISTING SPACES	1,629	
SPACES TO BE REMOVED	APPROX. 600	
MINIMUM PARKING IN OI-3	N/A	
PROPOSED MAXIMUM PARKING RATIO	4.5 SPACES PER 1000 SQ FT	

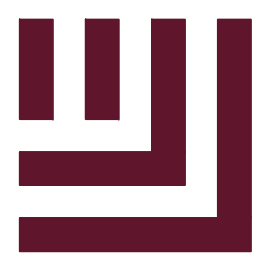

MCADAMS

The John R. McAdams Company, Inc.
621 Hillsborough Street
Suite 500
Raleigh, NC 27603
phone 919. 361. 5000
fax 919. 361. 2269
license number: C-0293, C-187

www.mcadamsco.com

CONTACT

WILLIAM H. DERKS, PE
derks@mcadamsco.com
PHONE: 919. 632. 0570

CLIENT

SIMON GEORGE, VP OF REAL ESTATE & DEVELOPMENT
211 FRIDAY CENTER DRIVE
CHAPEL HILL, NORTH CAROLINA, 27571
PHONE: 984. 974. 5388

PROJECT DIRECTORY

DCI LLC
DAVID PARKER
VICE PRESIDENT
DCI LLC

ANDY KING
PARTNER
GESTALT ARCHITECTURE + DESIGN PLLC

REVISIONS

NO.	DATE	DESCRIPTION
1	11. 21. 2022	FIRST SUBMITTAL
2	12. 19. 2022	SECOND SUBMITTAL
3	04. 06. 2023	THIRD SUBMITTAL

CONDITIONAL ZONING PLAN FOR:

UNC HEALTH EASTOWNE
CHAPEL HILL, NORTH CAROLINA
PROJECT NUMBER: UNH-22001

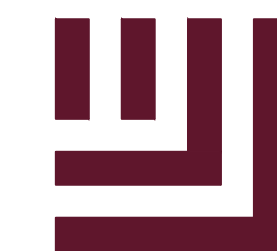

McADAMS

The John R. McAdams Company, Inc.
621 Hillsborough Street
Suite 500
Raleigh, NC 27603
phone 919. 361. 5000
fax 919. 361. 2269
license number: C-0293, C-187
www.mcadamsco.com

CLIENT
SIMON GEORGE, VP OF REAL ESTATE & DEVELOPMENT
211 FRIDAY CENTER DRIVE
CHAPEL HILL, NORTH CAROLINA, 27571
PHONE: 984.974.5388

UNC HEALTH EASTOWNE CONDITIONAL ZONING PLAN EASTOWNE DRIVE CHAPEL HILL, NORTH CAROLINA

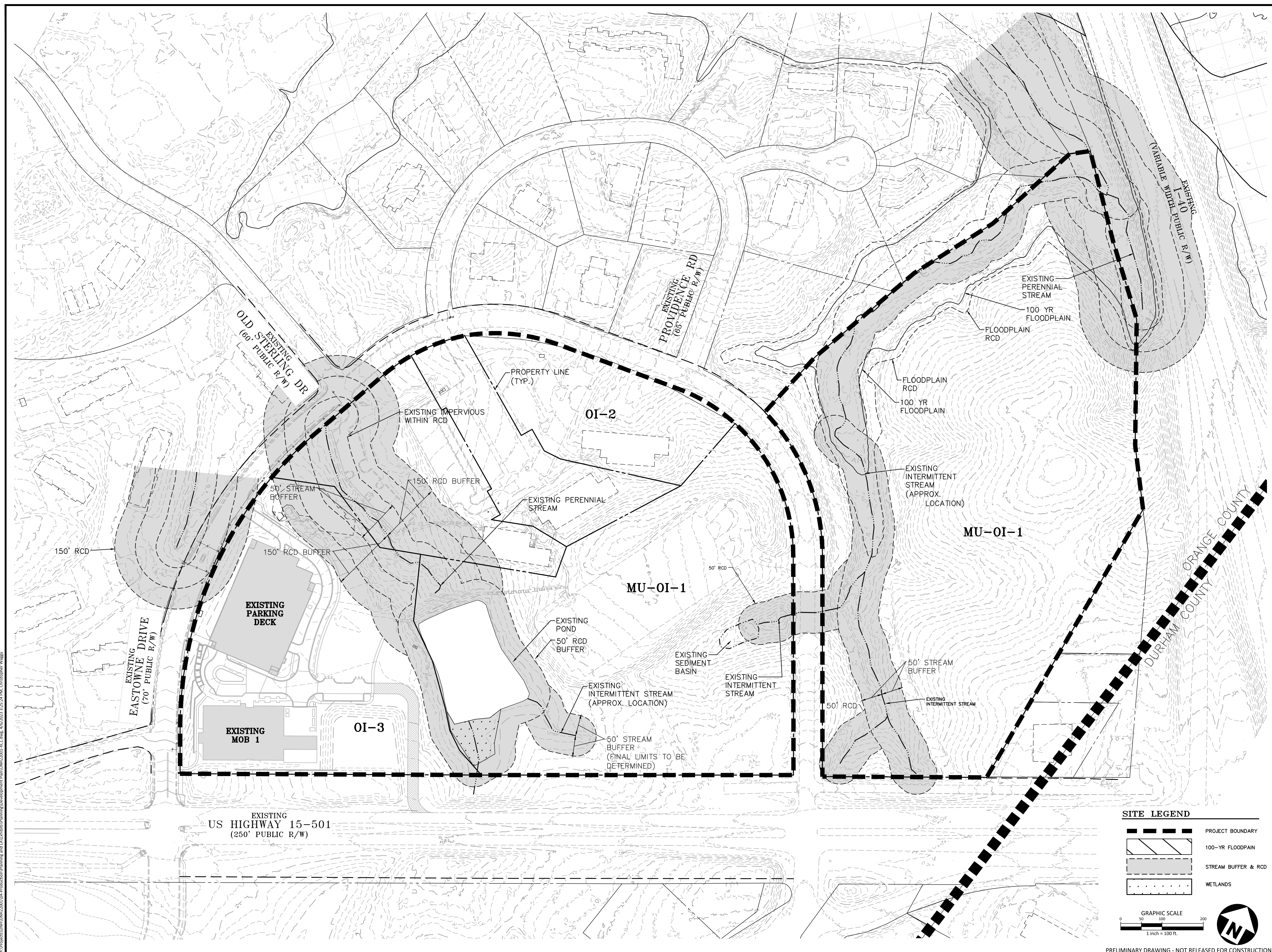

SITE LEGEND

	PROJECT BOUNDARY
	100-YR FLOODPLAIN
	STREAM BUFFER & RCD
	WETLANDS

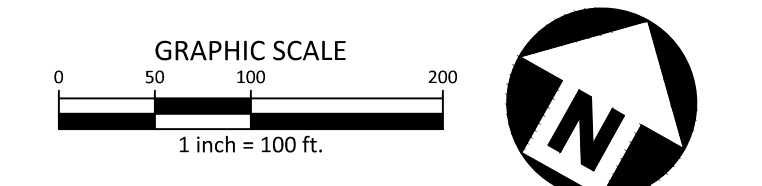

REVISIONS

NO.	DATE	DESCRIPTION
1	11.21.2022	FIRST SUBMITTAL
2	12.19.2022	SECOND SUBMITTAL
3	04.06.2023	THIRD SUBMITTAL

PLAN INFORMATION

PROJECT NO.	UNH-22001
FILENAME	
CHECKED BY	WHD
DRAWN BY	OR
SCALE	
DATE	03.30.2023

SHEET
EXISTING CONDITIONS
C1.00

M:\Projects\UNH\UNH22001\04-Production\Planning and L&ES\GIS\Planning\Development\Plan\UNH22001_XCL.dwg, 4/6/2023 3:28:24 PM, Christopher Waddy

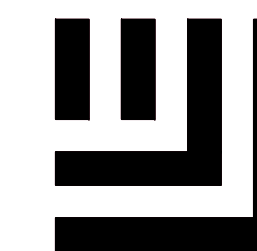

McADAMS

The John R. McAdams Company, Inc.
621 Hillsborough Street
Suite 500
Raleigh, NC 27603
phone 919. 361. 5000
fax 919. 361. 2269
license number: C-0293, C-187

www.mcadamsco.com

CLIENT

SIMON GEORGE, VP OF REAL ESTATE &
DEVELOPMENT
211 FRIDAY CENTER DRIVE
CHAPEL HILL, NORTH CAROLINA, 27571
PHONE: 984.974.5388

UNC HEALTH EASTWONE CONDITIONAL ZONING PLAN EASTWONE DRIVE CHAPEL HILL, NORTH CAROLINA

REVISIONS

NO.	DATE	DESCRIPTION
1	11.21.2022	FIRST SUBMITTAL
2	12.19.2022	SECOND SUBMITTAL
3	04.06.2023	THIRD SUBMITTAL

PLAN INFORMATION

PROJECT NO. UNH-22001
 FILENAME UNH22001-S1
 CHECKED BY WHD
 DRAWN BY OR
 SCALE 1"=200'
 DATE 12.19.2022

SHEET

AREA MAP C1.01

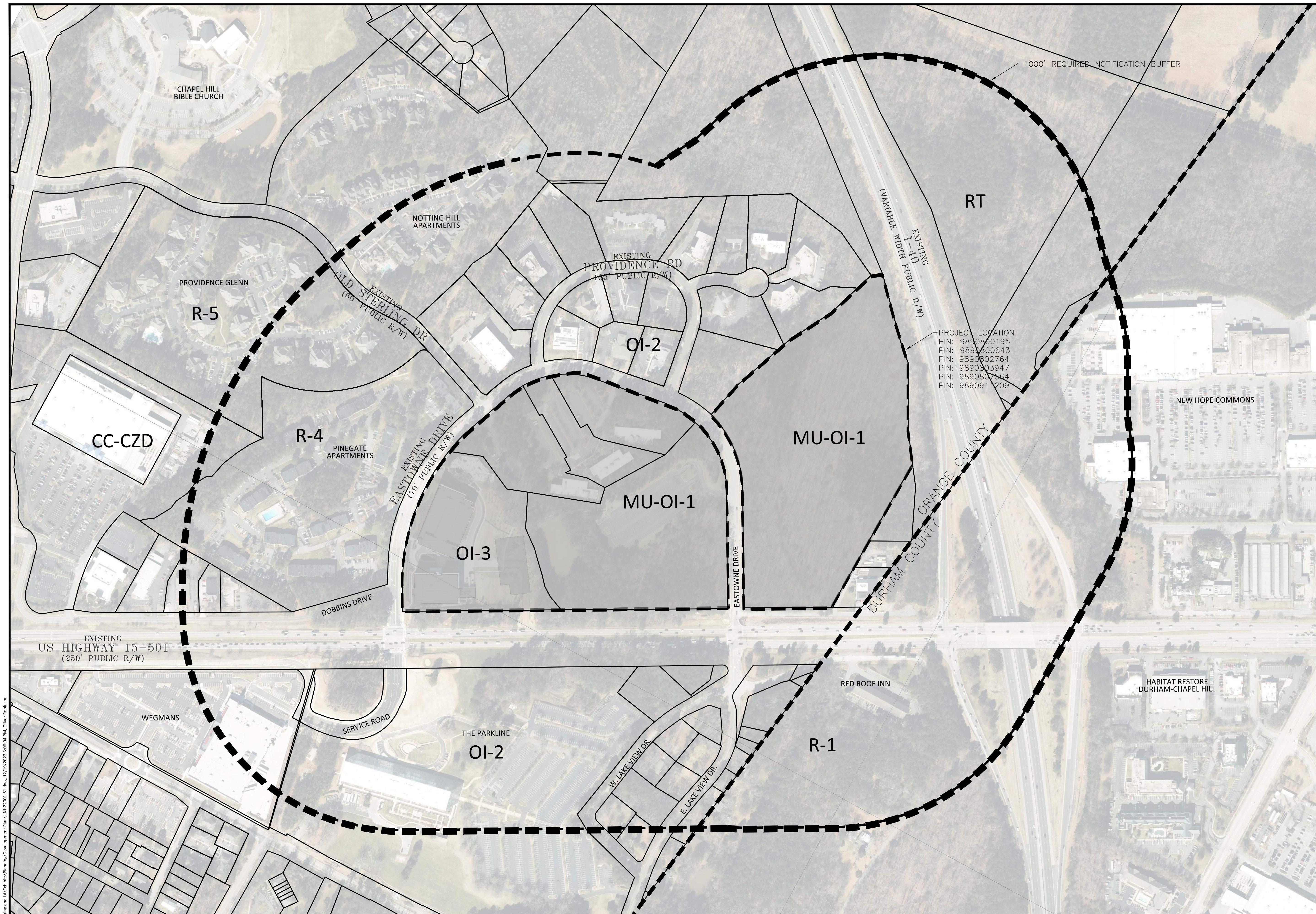

PROJECT LOCATION
 PIN: 9890800195
 PIN: 9890800643
 PIN: 9890802764
 PIN: 9890803947
 PIN: 9890807564
 PIN: 9890911209

LEGEND

- 1000' REQUIRED NOTIFICATION BOUNDARY
- PROJECT AREA
- APPROXIMATE ZONING DISTRICT LINE (INFORMATION FROM TOWN OF CHAPEL HILL GIS)

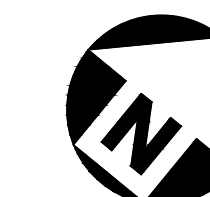
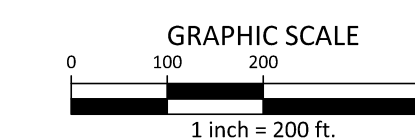

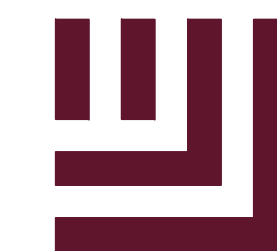

McADAMS

The John R. McAdams Company, Inc.
621 Hillsborough Street
Suite 500
Raleigh, NC 27603
phone 919. 361. 5000
fax 919. 361. 2269
license number: C-0293, C-187

www.mcadamsco.com

CLIENT

SIMON GEORGE, VP OF REAL ESTATE & DEVELOPMENT
211 FRIDAY CENTER DRIVE
CHAPEL HILL, NORTH CAROLINA, 27571
PHONE: 984.974.5388

**UNC HEALTH
EASTOWNE
CONDITIONAL ZONING PLAN
EASTOWNE DRIVE
CHAPEL HILL, NORTH CAROLINA**

REVISIONS

NO.	DATE	DESCRIPTION
1	11. 21. 2022	FIRST SUBMITTAL
2	12. 19. 2022	SECOND SUBMITTAL
3	04. 06. 2023	THIRD SUBMITTAL

PLAN INFORMATION

PROJECT NO.	UNH-22001
FILENAME	UNH22001-E1
CHECKED BY	WHD
DRAWN BY	OB
SCALE	1"=100'
DATE	03. 30. 2023

SHEET

STEEP SLOPES

C1.02

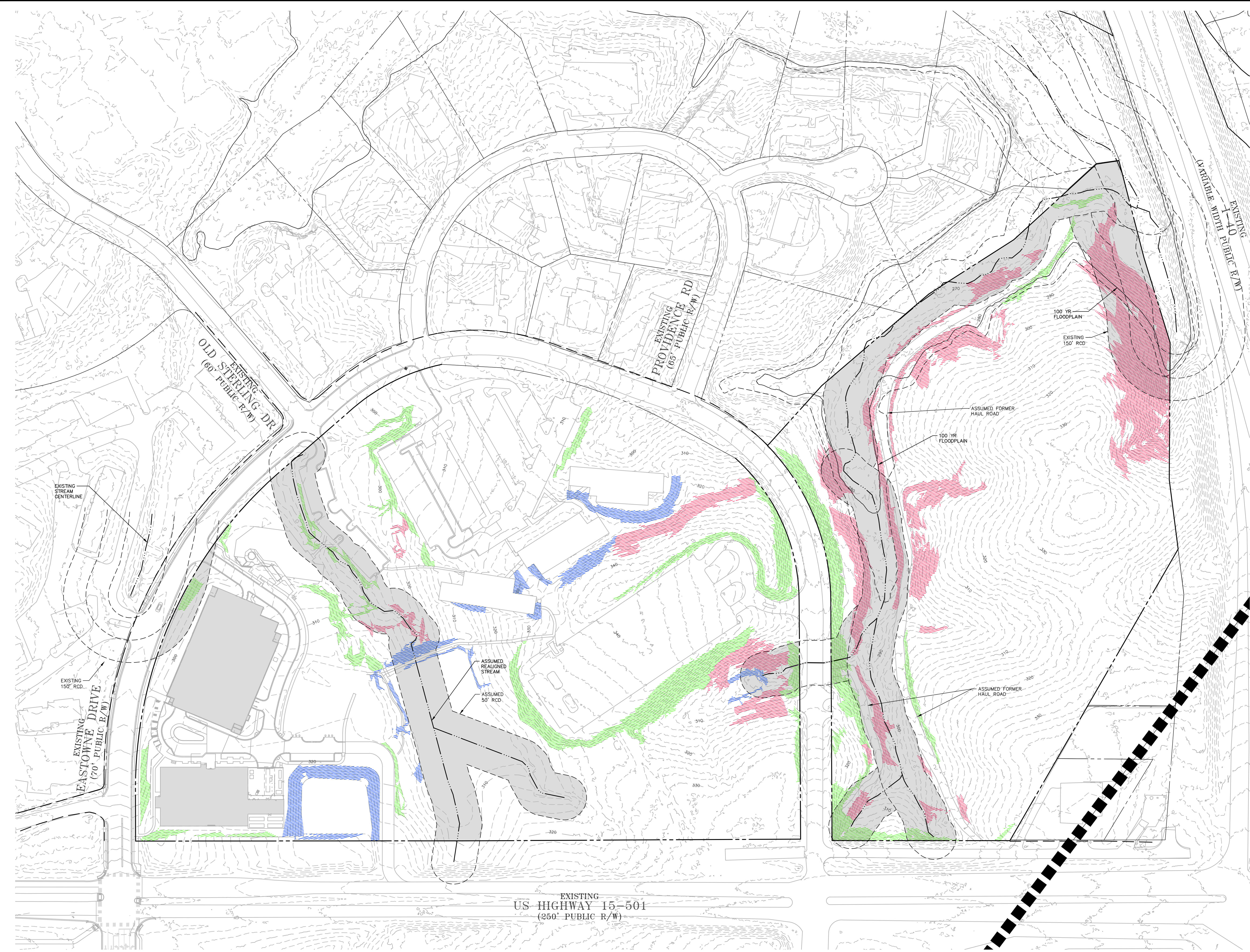

	> 25% SLOPE (APPLICABLE PER UDO)		> 25% SLOPE (NON-APPLICABLE PER UDO SECTION 5.3.2.D.3)		> 25% SLOPE (MAN-MADE NOT RECOGNIZED AS NON-APPLICABLE UNDER UDO SECTION 5.3.2.C.3)
TOTAL=135,316 SF/3.11 AC PROPOSED DISTURBED=40,595 SF/30%		TOTAL=108,565 SF/2.49 AC		TOTAL=36,055 SF/0.83 AC PROPOSED DISTURBED=36,055 SF/100%	

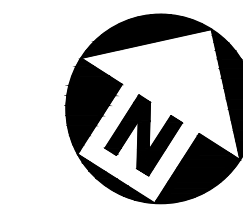
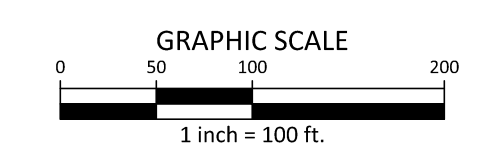

PRELIMINARY DRAWING - NOT RELEASED FOR CONSTRUCTION

M:\Projects\UNH\UNH22001\04-Production\Engineering\UNH22001\Steep Slopes\UNH22001-E1.dwg, 4/6/2023 1:37:50 PM, Christopher Wang

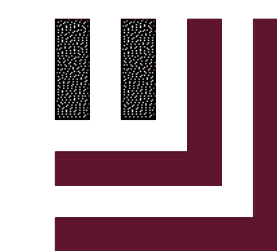

McADAMS

The John R. McAdams Company, Inc.
621 Hillsborough Street
Suite 500
Raleigh, NC 27603
phone 919. 361. 5000
fax 919. 361. 2269
license number: C-0293, C-187

www.mcadamsco.com

CLIENT

SIMON GEORGE, VP OF REAL ESTATE & DEVELOPMENT
211 FRIDAY CENTER DRIVE
CHAPEL HILL, NORTH CAROLINA, 27571
PHONE: 984.974.5388

**UNC HEALTH
EASTOWNE
CONDITIONAL ZONING PLAN
EASTOWNE DRIVE
CHAPEL HILL, NORTH CAROLINA**

REVISIONS

NO.	DATE	DESCRIPTION
1	11.21.2022	FIRST SUBMITTAL
2	12.19.2022	SECOND SUBMITTAL
3	04.06.2023	THIRD SUBMITTAL

PLAN INFORMATION

PROJECT NO. UNH-22001
FILENAME UNH22001-S1
CHECKED BY WHD
DRAWN BY OR
SCALE 1"=100'
DATE 03.30.2023

SHEET

**OVERALL CONCEPT
PLAN
C2.00**

- NOTES:**
1. CONFIGURATION OF ACCESS LOCATIONS TO BE CONFIRMED BY A TRAFFIC IMPACT ANALYSIS SUBMITTED WITH EACH PHASE.
 2. ACCESS POINTS MAY SHIFT DURING PREPARATION OF FINAL PLANS AND PHASE SPECIFIC TRAFFIC STUDIES.
 3. MAXIMUM BUILDING HEIGHT MAY INCREASE BY 15% DURING DEVELOPMENT OF FINAL DESIGN. TO BE APPROVED AS A MINOR MODIFICATION BY STAFF.
 4. RCD IMPACTS FOR ROAD CROSSINGS, DRAINING OF THE EXISTING POND, STREAM RESTORATION AND SCM#2 ARE APPROVED AS PART OF THIS CZ PLAN. EXACT SQUARE FOOTAGE REQUIRED WILL BE DETERMINED WITH THE FINAL PLANS.
 5. BUBBLE AREAS AND OUTLINES OF SCMS ARE DIAGRAMATIC AND MAY CHANGE IN SHAPE DURING PREPARATION OF THE FINAL DESIGNS.

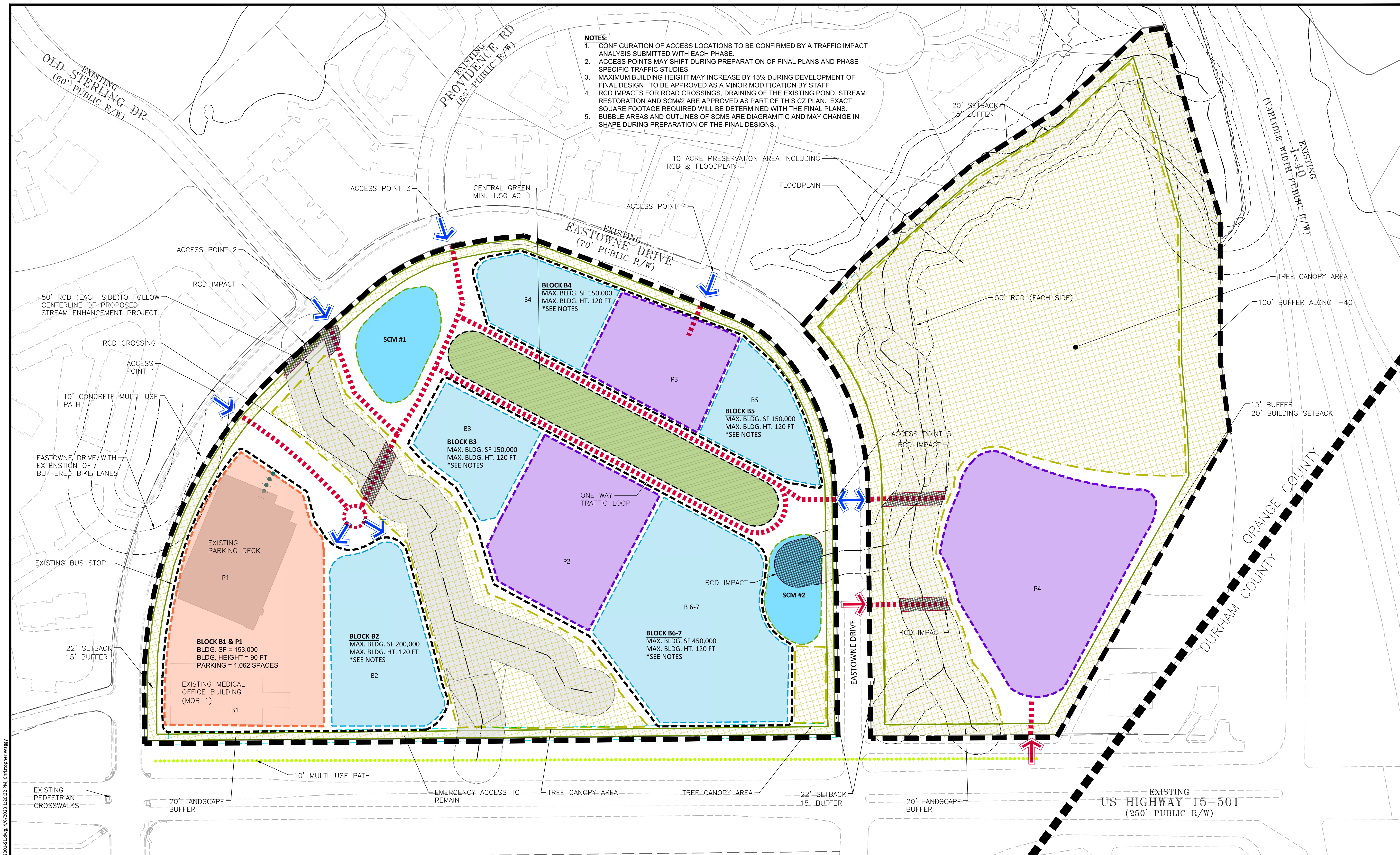

LEGEND

- EXISTING DEVELOPMENT
 - PARKING BLOCK
 - BUILDING BLOCK
 - DEVELOPMENT BLOCK
 - TREE CANOPY
 - STREAM/ RCD BUFFER
 - SCM
 - PROPOSED ROAD
 - MULTI-USE PATH
 - PROJECT BOUNDARY
 - RCD IMPACT
- SITE ACCESS
* INTERNAL CONNECTIVITY IS PROPOSED AND SUBJECT TO CHANGE
 - POTENTIAL EMERGENCY SITE ACCESS
* INTERNAL CONNECTIVITY IS PROPOSED AND SUBJECT TO CHANGE

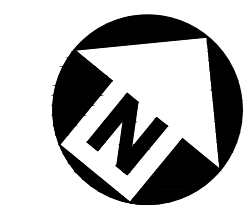
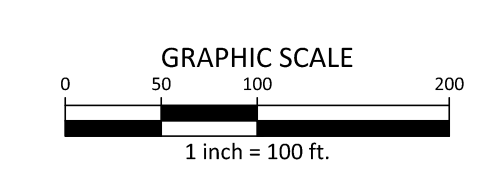

M:\Projects\UNH\UNH22001\04-Production\Planning and LAs\Subs\Planning\Development Plan\UNH22001-S1.dwg, 4/6/2023, 1:03:32 PM, Christopher Wiley

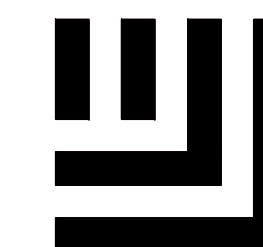

McADAMS

The John R. McAdams Company, Inc.
621 Hillsborough Street
Suite 500
Raleigh, NC 27603
phone 919. 361. 5000
fax 919. 361. 2269
license number: C-0293, C-187

www.mcadamsco.com

CLIENT

SIMON GEORGE, VP OF REAL ESTATE & DEVELOPMENT
211 FRIDAY CENTER DRIVE
CHAPEL HILL, NORTH CAROLINA, 27571
PHONE: 984.974.5388

UNC HEALTH EASTOWNE CONDITIONAL ZONING PLAN EASTOWNE DRIVE CHAPEL HILL, NORTH CAROLINA

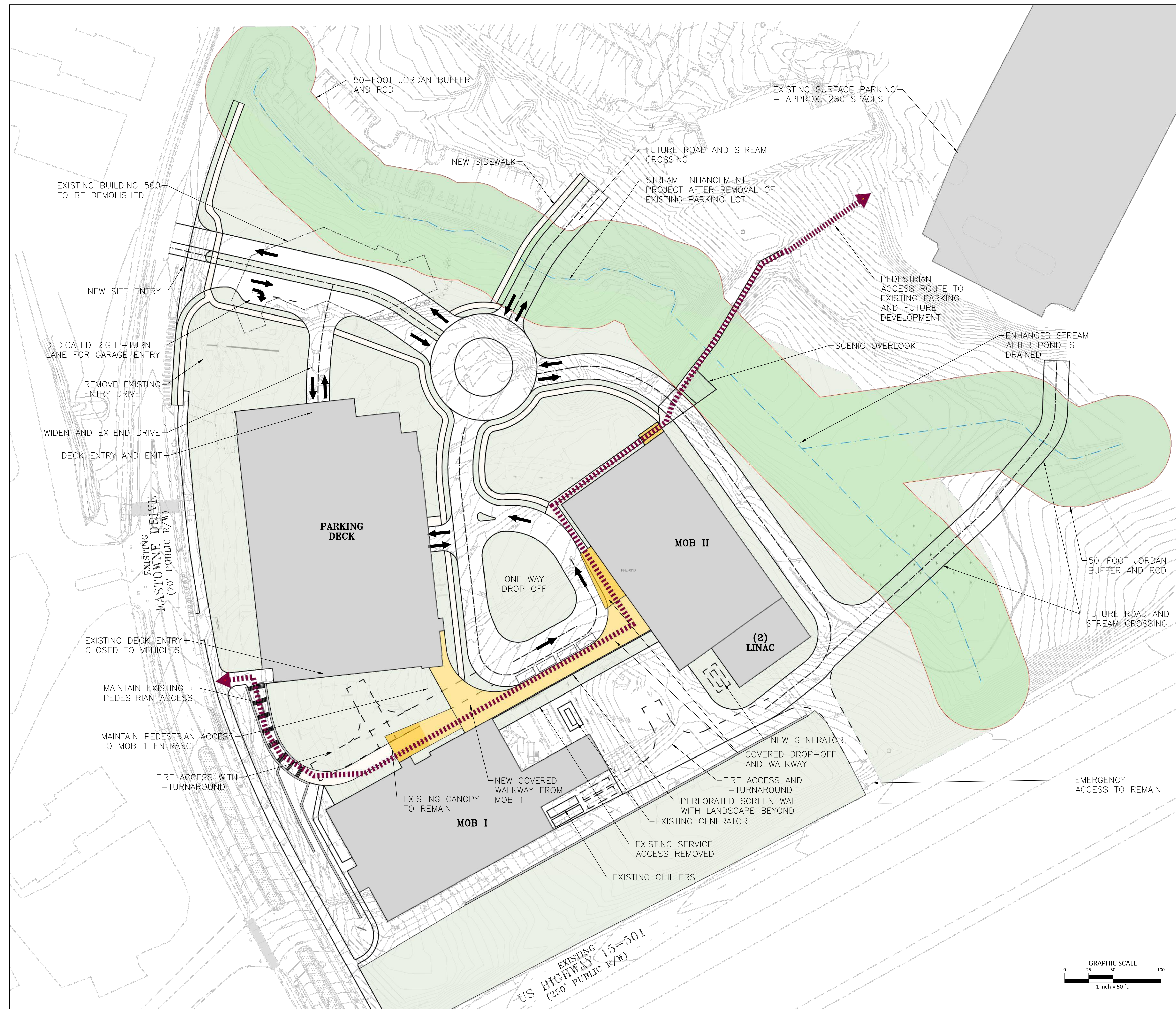

REVISIONS

NO.	DATE	DESCRIPTION
1	11.21.2022	FIRST SUBMITTAL
2	12.19.2022	SECOND SUBMITTAL
3	04.06.2023	THIRD SUBMITTAL

PLAN INFORMATION

PROJECT NO.	UNH-22001
FILENAME	UNH22001-S1
CHECKED BY	WHD
DRAWN BY	OR
SCALE	1"=50'
DATE	12.19.2022

SHEET

MOB 2
CONCEPT PLAN

C2.01

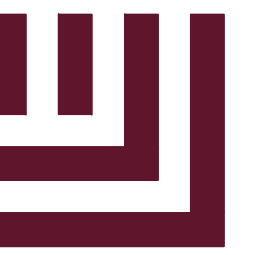

McADAMS

The John R. McAdams Company, Inc.
621 Hillsborough Street
Suite 500
Raleigh, NC 27603
phone 919. 361. 5000
fax 919. 361. 2269
license number: C-0293, C-187

www.mcadamsco.com

CLIENT

SIMON GEORGE, VP OF REAL ESTATE & DEVELOPMENT
211 FRIDAY CENTER DRIVE
CHAPEL HILL, NORTH CAROLINA, 27571
PHONE: 984.974.5388

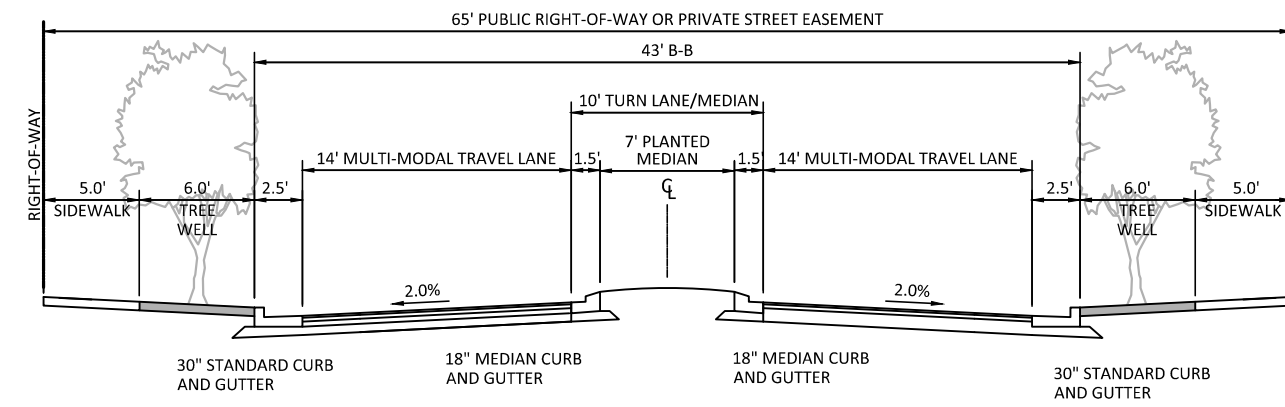

TYPICAL SECTION
PRIVATE STREET-WITH MEDIAN
(65' R/W, 43' B-B)

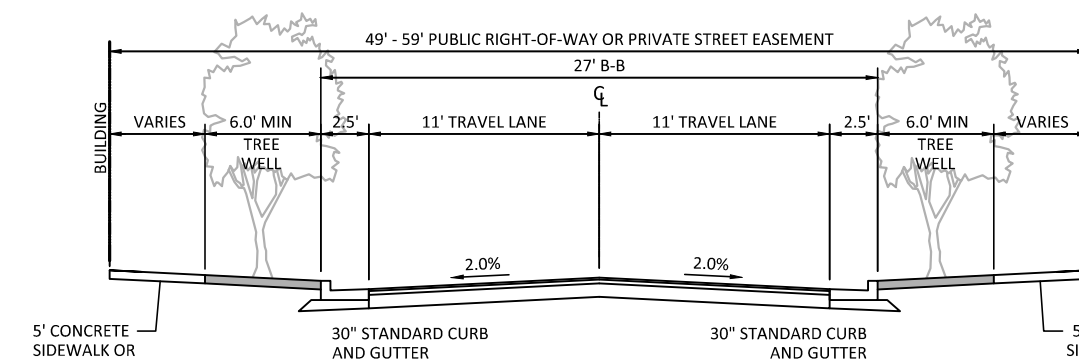

TYPICAL SECTION
PRIVATE STREET WITH TREE WELL
(49' - 59' R/W, 27' B-B)

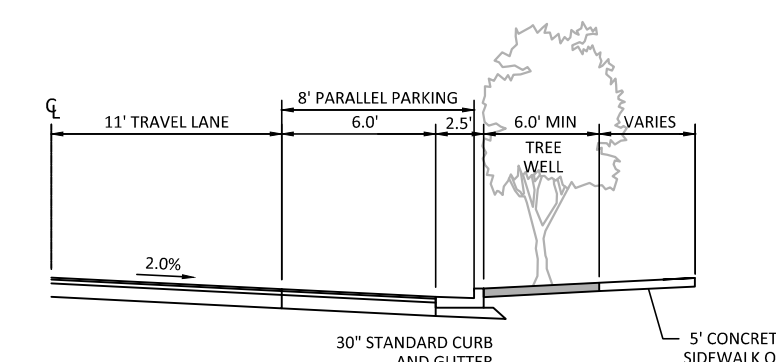

PARALLEL PARKING OPTION

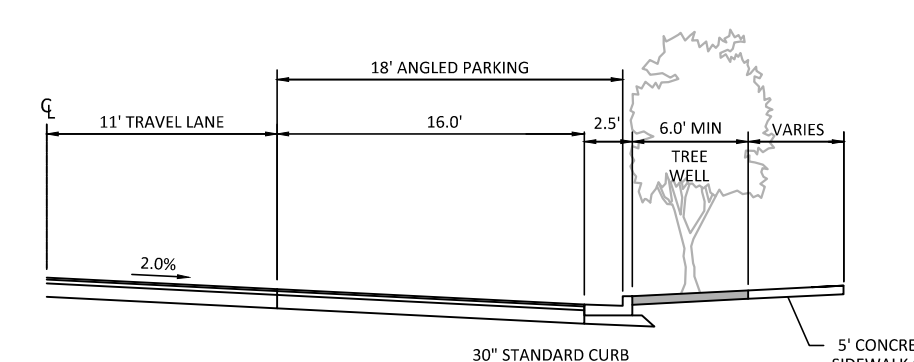

ANGLED PARKING OPTION

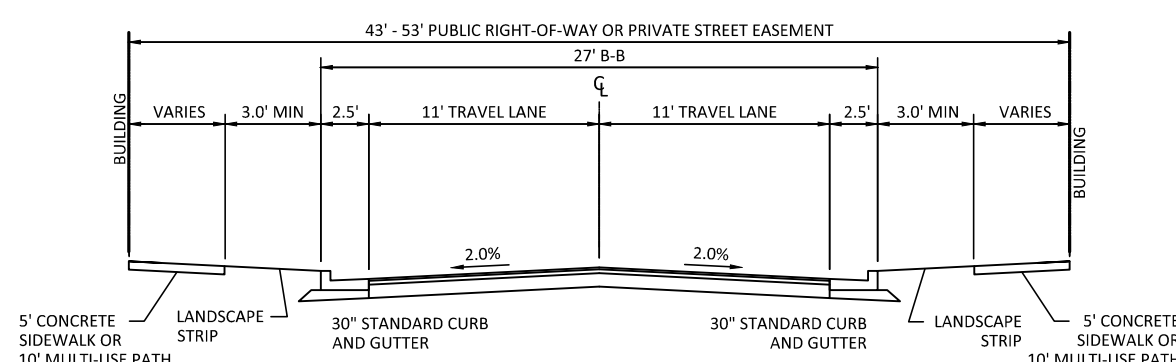

TYPICAL SECTION
PRIVATE STREET WITH LANDSCAPE STRIP
(43' - 53' R/W, 27' B-B)

* LANDSCAPE STRIP MAY BE REMOVED WITH 6-FOOT WIDE SIDEWALK AT THE BACK-OF-CURB TO REDUCE STREAM CROSSING WIDTH.

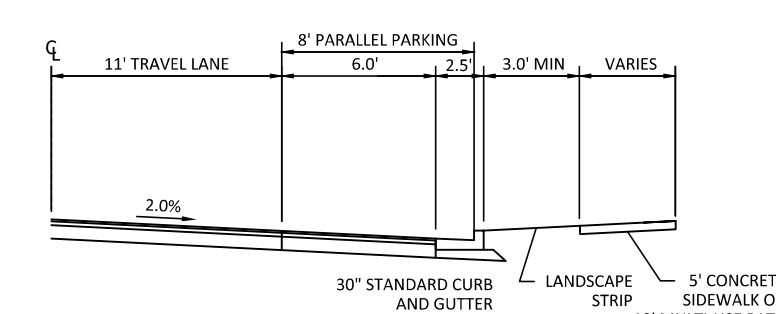

PARALLEL PARKING OPTION

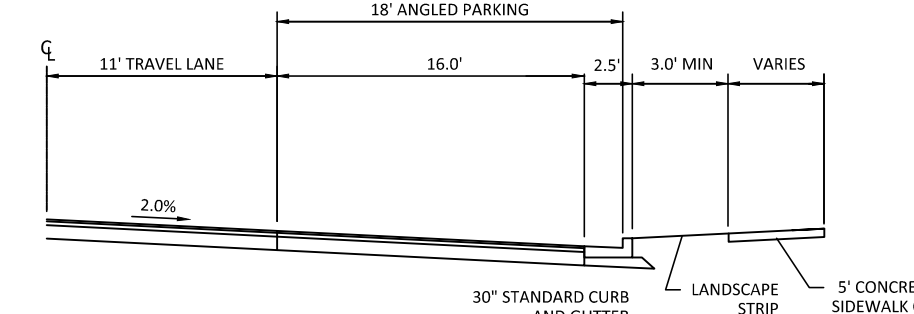

ANGLED PARKING OPTION

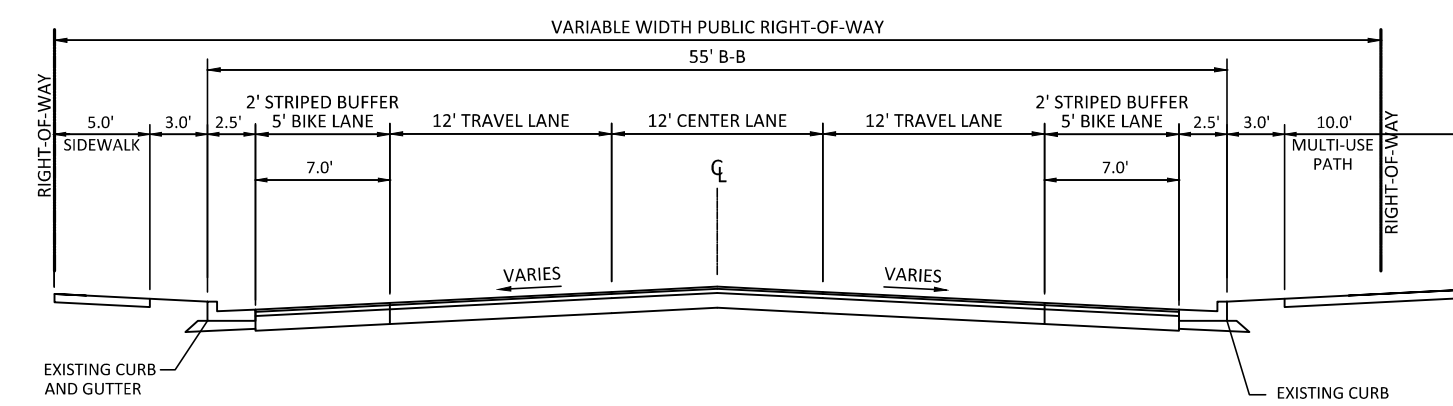

TYPICAL SECTION
EXISTING EASTOWNE DRIVE
(VARIABLE WIDTH R/W, ~55' B-B)

**UNC HEALTH
EASTOWNE
CONCEPT PLAN
EASTOWNE DRIVE
CHAPEL HILL, NORTH CAROLINA**

REVISIONS

NO.	DATE	DESCRIPTION
1	11. 21. 2022	FIRST SUBMITTAL
2	12. 19. 2022	SECOND SUBMITTAL

PLAN INFORMATION

PROJECT NO. UNH-22001
FILENAME UNH22001-SECTIONS
CHECKED BY WHD
DRAWN BY OR
SCALE 1"=10'
DATE 12. 19. 2022

SHEET

**STREET
SECTIONS**

C3.00