

# 324 ROSEMARY MIXED-USE

324 W. ROSEMARY STREET, CHAPEL HILL, NORTH CAROLINA

**PROJECT TEAM:**  
**ARCHITECT**  
 MHA WORKS  
 501 WASHINGTON ST.  
 DURHAM, NC 27701  
 P: 919-682-2870  
 JMARTINSON@MHAWORKS.COM

**CIVIL ENGINEER**  
 COULTER JEWELL THAMES PA  
 111 WEST MAIN STREET  
 DURHAM, NC, 27701  
 P: 919.682.0368  
 PROYSTER@CJTFA.COM

**LANDSCAPE ARCHITECT**  
 COULTER JEWELL THAMES PA  
 111 WEST MAIN STREET  
 DURHAM, NC, 27701  
 P: 919.682.0368  
 JANDERSON@CJTFA.COM



**Coulter  
Jewell  
Thames**

111 West Main Street  
 Durham, N.C. 27701  
 p 919.682.0368  
 f 919.688.5646  
 www.cjtfa.com

Project:

**324 ROSEMARY  
MIXED-USE**

324 W ROSEMARY ST.  
 CHAPEL HILL, NC 27516

ORANGE COUNTY  
 NORTH CAROLINA

PIN: 9788178053

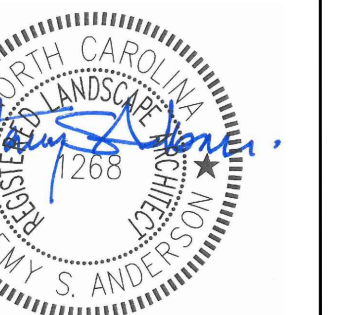

PRELIMINARY  
 NOT FOR CONSTRUCTION

Job Number: 1663

Drawn	JSA, ED
Checked	JSA
Date	03.17.2017
Revisions	02.19.2020 COMMENTS
	04.24.2020 COMMENTS

SITE PLAN

Sheet Title:

**COVER SHEET**

Sheet Number

**C000**

## PROJECT DATA

EXISTING SITE INFORMATION	PROPERTY 1:	PROPERTY 2:	PROPERTY 3:	PROPERTY 4:	PROPERTY 5:
OWNER	AMITY STATION LLC	AMITY STATION LLC	AMITY STATION LLC	AMITY STATION LLC	AMITY STATION LLC
PIN	9788178220	9788270263	9788179085	9788170111	9788178503
ACREAGE	44,867 SF / 1.03 AC	6,149 SF / 0.14 AC	10,890 SF / 0.25 AC	2,614 SF / 0.06 AC	28,314 SF / 0.65 AC
EXISTING USE	DWELLING UNITS; 7 OR MORE	PRIVATE ROAD	PARKING OFF-STREET	PRIVATE ROAD	BUSINESS-CONVENIENCE
SITE/PROJECT ADDRESS	1,2,3,4,5,6&7 AMITY CT. CHAPEL HILL, NC 27516	AMITY CT. CHAPEL HILL, NC 27516	318 W. ROSEMARY ST. CHAPEL HILL, NC 27516	AMITY CT. CHAPEL HILL, NC 27516	322 & 324 W. ROSEMARY ST. CHAPEL HILL, NC 27516
ZONING INFORMATION					
EXISTING ZONING	R-3	TC-2	TC-2	TC-2	TC-2
USE GROUP	A	A	A	A	A
RIVER BASIN	CAPE FEAR	CAPE FEAR	CAPE FEAR	CAPE FEAR	CAPE FEAR

## PROPOSED SITE INFORMATION

NET LAND AREA:		
TC-2	9,494 SF / 0.22 AC	
R-3	1,668 SF / 0.04 AC	
TOTAL	11,162 SF / 0.26 AC	
GROSS LAND AREA:		
TC-2	9,494 SF / 0.22 AC	
CSA (10% NLA)	1,116.2 SF / 0.02 AC	
R-3	1,668 SF / 0.04 AC	
TOTAL	12,278.2 SF / 0.28 AC	
DISTURBED AREA:	39,638 SF / 0.91 AC	
SITE AREA IN 100 YEAR FLOODPLAIN (INCLUDES FLOODWAY)	N/A	
PROPOSED USE:	PRIMARY: DWELLING UNITS; 7 OR MORE	SECONDARY: BUSINESS

## BUILDING INFORMATION

EXISTING BUILDING SIZE:	6,037 SF (BREADMEN'S)	
PROPOSED BUILDING SIZE:	19,999 SF	
TOTAL BUILDING SIZE:	19,999 SF	
FLOOR AREA RATIO:		
MAX. ALLOWED		
TC-2	1.97 x 10,610.2 SF GLA = 20,902.09 SF	
R-3	1.62 x 1,668 SF GLA = 270.22 SF	
TOTAL	21,172.31 SF	
BUILDING USE:	MIXED USE	
RESIDENTIAL	MAX. 20 UNITS	
BUSINESS	MIN. 200 SF	
DENSITY:	20 UNITS / 0.28 GLA = 71 UNITS PER ACRE	
VEHICULAR PARKING SPACES	<u>DWELLING UNITS: MAX. 20 UNITS</u>	<u>BUSINESS: MIN. 200 SF</u>
MINIMUM:	N/A (TOWN CENTER)	N/A (TOWN CENTER)
MAXIMUM:	1.67 / DWELLING UNIT (1.67 x 20 = 33 MAX)	1 / 375 SF FLOOR AREA (200 / 375 = 1 MAX)
EXISTING:	N/A	
PROPOSED:	14 SPACES	
TOTAL VEHICULAR PARKING SPACES:	1 ADA SPACE 4 COMPACT SPACES 9 REGULAR SPACES 14 TOTAL PARKING SPACES	BUSINESS: MIN. 200 SF MIN. 4 ; 2 ADD'L / 2,500 SF FLOOR AREA = 4 SPACES 4 x 0.8 = 3.2 CLASS I SPACES 4 x 0.8 = 0.8 CLASS II SPACES
BICYCLE PARKING SPACES REQUIRED:	<u>DWELLING UNITS: MAX. 20 UNITS</u> 1 / 4 UNITS = 5 SPACES 5 x 0.9 = 4.5 CLASS I SPACES 5 x 0.1 = 0.5 CLASS II SPACES	4.5 + 3.2 = 7.7 = 8 CLASS I SPACES REQUIRED TOTAL 0.5 + 0.8 = 1.3 = 1 CLASS II SPACE REQUIRED TOTAL
PROPOSED:	MIN. 8 CLASS I SPACES MIN. 1 CLASS II SPACES	
IMPERVIOUS SURFACE		
EXISTING:	10,409 SF / 0.24 AC	
IMPERVIOUS PROPOSED:	9,777 SF / 0.22 AC	
TOTAL IMPERVIOUS SURFACE:	9,777 SF / 0.22 AC	
TREE CANOPY COVERAGE	N/A (TOWN CENTER)	

## OVERALL SITE MAP

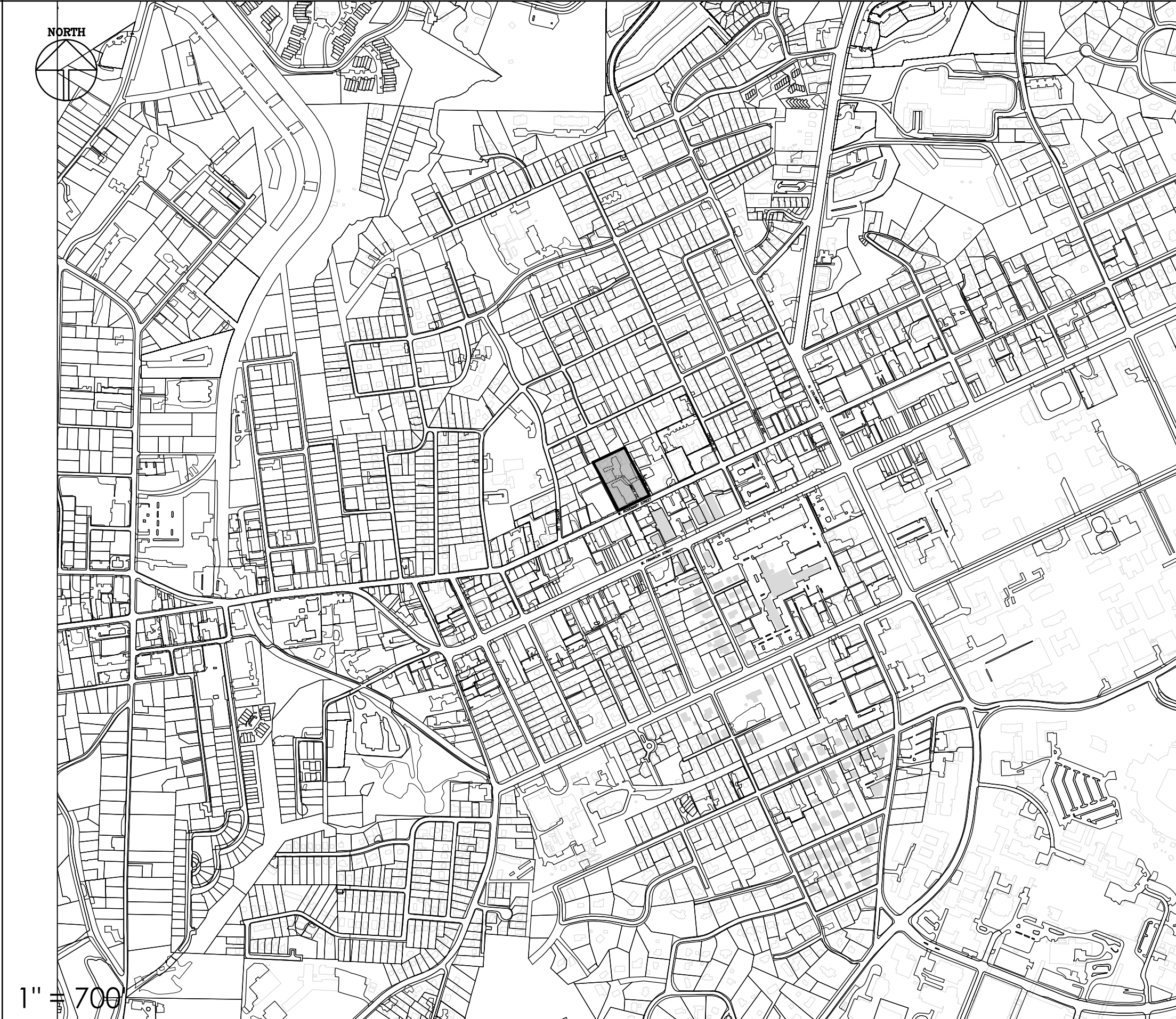

## TOWN OF CHAPEL HILL NOTES

- A FIRE FLOW REPORT SHALL BE SUBMITTED TO THE TOWN FOR REVIEW AND APPROVAL PRIOR TO ISSUANCE OF A ZCP.
- P.E. CERTIFICATION: PRIOR TO THE ISSUANCE OF A CERTIFICATE OF OCCUPANCY FOR ANY PHASE, THE APPLICANT SHALL PROVIDE A CERTIFICATION, SIGNED AND SEALED BY A NORTH CAROLINA-LICENSED PROFESSIONAL ENGINEER, THAT THE STORMWATER MANAGEMENT FACILITY IS CONSTRUCTED IN ACCORDANCE WITH THE APPROVED PLANS AND SPECIFICATIONS.
- AS-BUILT PLANS: PRIOR TO THE ISSUANCE OF A CERTIFICATE OF OCCUPANCY, THE APPLICANT SHALL PROVIDE CERTIFIED AS-BUILT PLANS FOR BUILDING FOOTPRINTS, PARKING LOTS, STREET IMPROVEMENTS, STORM DRAINAGE SYSTEMS AND STORMWATER MANAGEMENT STRUCTURES, AND ALL OTHER IMPERVIOUS SURFACES, AND A TALLY OF THE CONSTRUCTED IMPERVIOUS AREA. THE AS-BUILT PLANS SHOULD BE IN DXF BINARY FORMAT USING STATE PLANE COORDINATES AND NAVD83.
- ANY RETAINING WALLS OVER FIVE (5) FEET HIGH SHALL BE PERMITTED SEPARATELY FROM THE BUILDING(S) AND MUST BE SIGNED BY A DESIGN PROFESSIONAL.
- PROVIDE ONSITE PARKING FOR INSPECTORS AT EACH BUILDING FOR THE DURATION OF THE CONSTRUCTION PROJECT.
- PROVIDE A TIRE WASH FOR TRUCKS ONSITE BEFORE THEY HIT THE MAIN ROADS.
- CURB AND GUTTER AND AT LEAST THE FIRST LIFT OF ASPHALT FOR THE ROADS MUST BE DOWN AHEAD OF CONSTRUCTION.
- A SINGLE ELECTRICAL SERVICE SHALL BE PROVIDED TO SERVE THE STRUCTURE WITH THE EXCEPTION OF THE FIRE PUMP. ARTICLE 230.2 (A) 2017 EDITION OF NORTH CAROLINA ELECTRIC CODE.
- PRIOR TO ISSUANCE OF A CERTIFICATE OF OCCUPANCY, THE APPLICANT SHALL PROVIDE THE MINIMUM REQUIRED HANDICAPPED PARKING SPACES AND DESIGN ALL HANDICAPPED PARKING SPACES, RAMPS, AND CROSSWALKS, AND ASSOCIATED INFRASTRUCTURE ACCORDING TO AMERICANS WITH DISABILITIES ACT STANDARDS, NORTH CAROLINA BUILDING CODE, AMERICAN NATIONAL STANDARDS INSTITUTE (ANSI) CODE, AND TOWN STANDARD.
  - PARKING - NUMBER OF SPACES TO COMPLY WITH NCBC 2018 SECTION 1106.1, 1 PER 6 COMPLIANT SPACES OR PORTION THEREOF MUST BE VAN ACCESSIBLE, NO SLOPE TO EXCEED 2% IN ANY DIRECTION. SIGNAGE PER NC REQUIREMENTS, MUT-CD AND ICC A 117.1.
  - CURB CUTS AND ACCESSIBLE ROUTES PER ICC A117.1 2009 ED. CROSS SLOPE LIMITED TO 2%, CALL FOR INSPECTION BEFORE PLACEMENT OF CONCRETE.
  - SLOPE GREATER THAN 5% REQUIRES CONSTRUCTION AS A RAMP.
- A SEPARATE SUBMITTAL AND PERMIT WILL BE REQUIRED FOR ANY SIGNAGE ON THE BUILDING OR GROUND MOUNTED SIGNS
- ALL CONSTRUCTION AND DEMOLITION CONDUCTED SHALL BE IN COMPLIANCE OF THE CURRENT EDITION OF THE NC FIRE CODE, 2018 NCFRC CHAPTER 33

## RESOURCE CONSERVATION NOTES

**STREAM BUFFERS:**  
 THERE ARE NO MAPPED STREAMS OR ASSOCIATED STREAM BUFFERS LOCATED ON SITE. A DETERMINATION WAS COMPLETED BY CHAPEL HILL PUBLIC WORKS.

**FLOODPLAIN PROTECTION:**  
 THE SITE IS NOT AFFECTED BY A MAPPED FLOODPLAIN ACCORDING TO FIRM MAPS 3710978800 J (FEBRUARY 2, 2007).

**STEEP SLOPE PROTECTION:**  
 THERE ARE NO AREAS OF STEEP SLOPES GREATER THAN 15% LOCATED ON SITE.

**TREE SURVEY:**  
 THE TREE SURVEY SHOWS ALL 18" CAL. OR LARGER TREES ON THE EXISTING CONDITIONS PLAN.

**WETLANDS:**  
 THERE ARE NO MAPPED WETLANDS ONSITE.

**TREE PROTECTION:**  
 REFER TO SHEET C102 AND C500.

## VICINITY MAP

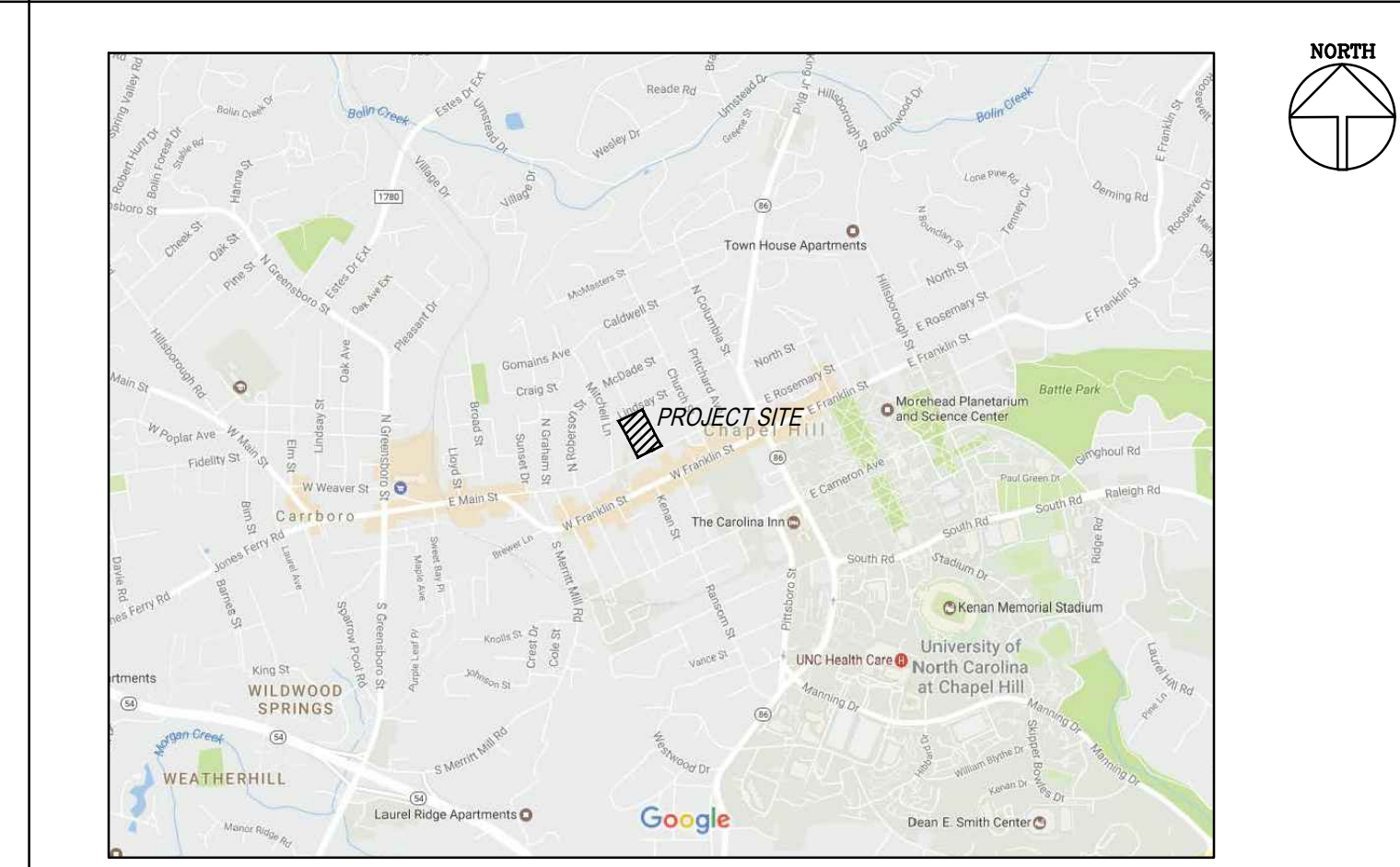

## PROJECT NOTES

- TOPOGRAPHIC INFORMATION BASED ON SURVEY BY PHILIP POST & ASSOC. A DIVISION OF PENONNI DATED JANUARY, 2014.
- THERE ARE EXISTING TRANSIT STOPS ALONG ROSEMARY.
- ALL CONSTRUCTION SHALL BE DONE IN ACCORDANCE WITH ALL TOWN OF CHAPEL HILL STANDARDS AND SPECIFICATIONS.

## LIST OF SHEETS

C000	COVER SHEET
C100	AREA MAP
C101	EXISTING CONDITIONS & TREE PROTECTION PLAN
C102	DEMOLITION & CONSTRUCTION MANAGEMENT PLAN
C200	SITE LAYOUT PLAN
C201	EASEMENT EXHIBIT
C300	GRADING AND STORM DRAINAGE PLAN
C301	EROSION CONTROL PLAN
C400	UTILITY AND LIGHTING PLAN
C500	LANDSCAPE & STREETScape PLAN
C600	SITE DETAILS
C700	EROSION CONTROL PLAN
C701	EROSION CONTROL DETAILS
318.AS1	BUILDING MASSING SECTION

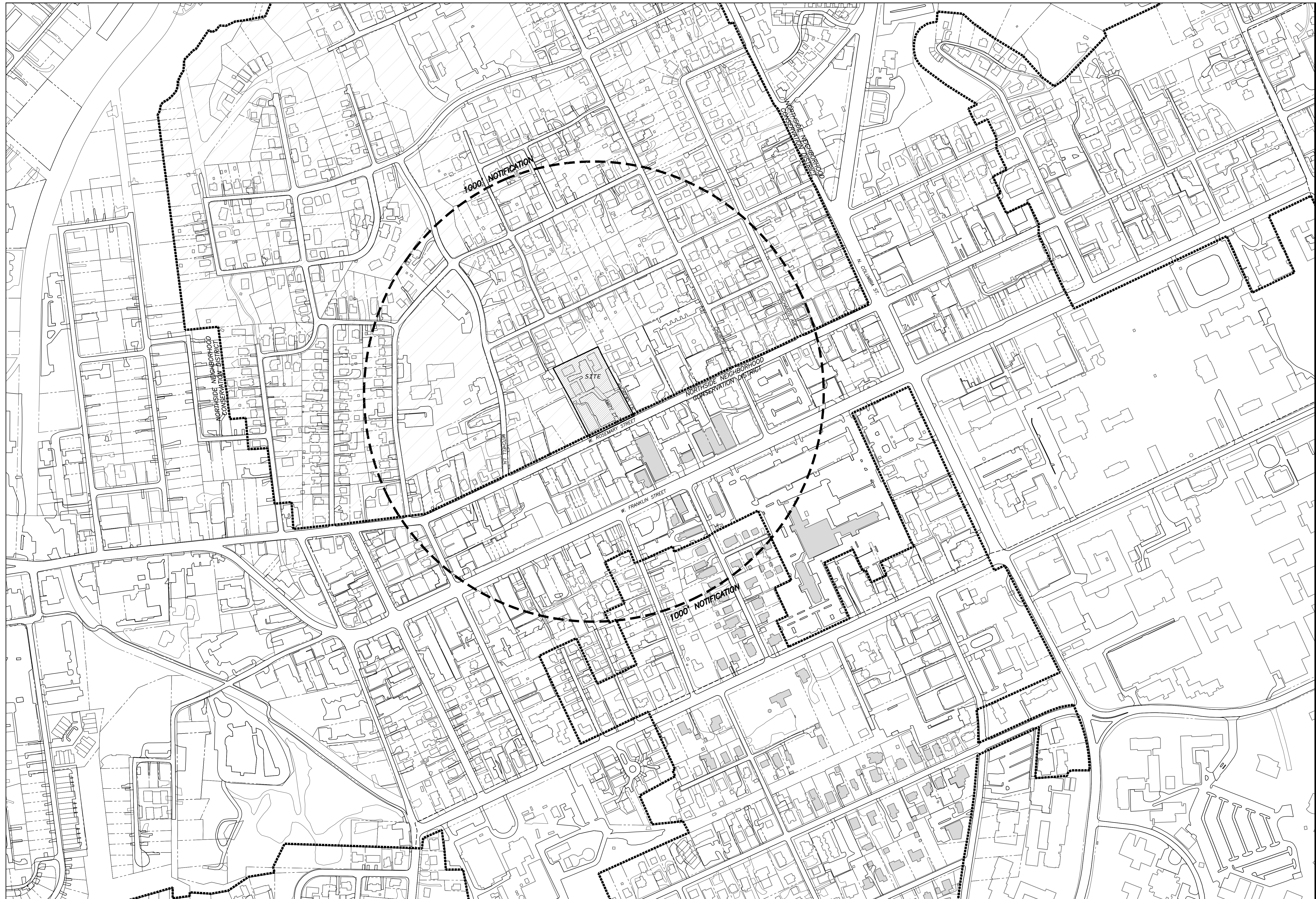

Project:  
**324 ROSEMARY  
MIXED-USE**

324 W ROSEMARY ST.  
CHAPEL HILL, NC 27516

ORANGE COUNTY  
NORTH CAROLINA

PIN: 9788178053



PRELIMINARY  
NOT FOR CONSTRUCTION

Job Number: 1663

Drawn	JSA, ED
Checked	JSA
Date	03.17.2017
Revisions	02.19.2020 COMMENTS
	04.24.2020 COMMENTS

SITE PLAN  
Sheet Title:

**AREA  
MAP**

Sheet Number  
**C001**

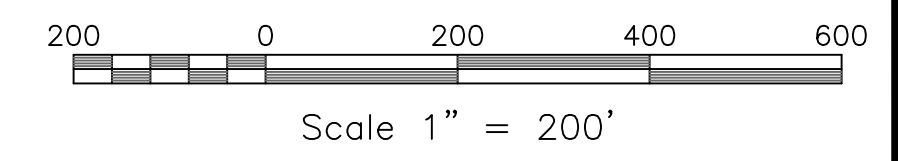

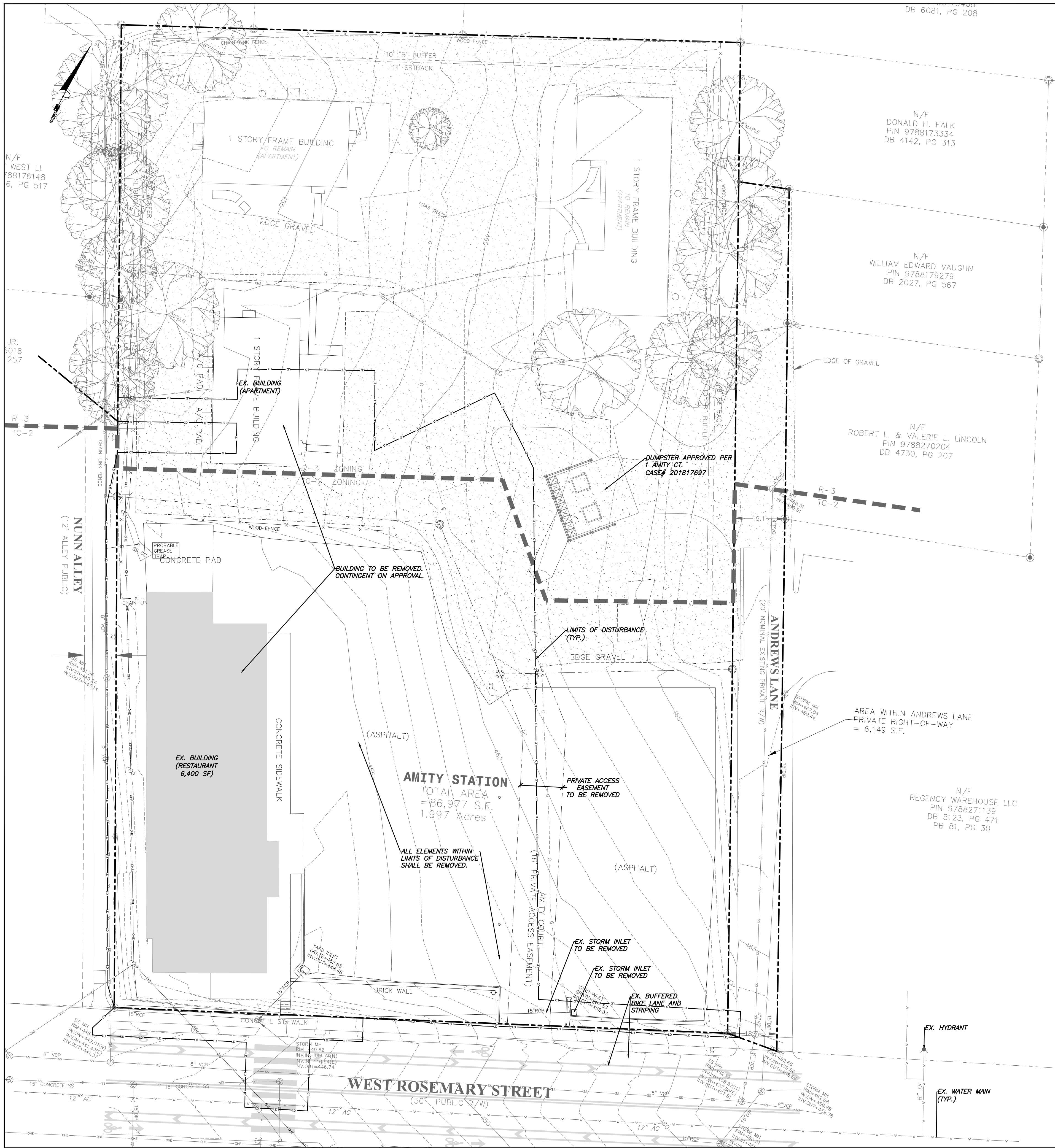

1/C101  
EXISTING CONDITIONS, DEMOLITION & TREE PROTECTION PLAN  
SCALE: 1"=20'

**demolition notes**

1. ENSURE ALL EROSION CONTROL MEASURES ARE IN PLACE AND IN WORKING ORDER PRIOR TO THE START OF ANY DEMOLITION AND CONSTRUCTION.
2. SEE SITE PLAN SHEET C101 FOR LAYOUT DIMENSIONS OF EXTENT OF DEMOLISHED AREAS. PAVED AREAS NOT INDICATED TO BE DEMOLISHED, ARE TO REMAIN. ALL CONCRETE SAW CUTS ARE TO BE CLEAN, STRAIGHT AND NEAT.
3. UTILITIES: SEE UTILITY PLAN C400. CONTRACTOR TO COORDINATE WITH UTILITY COMPANIES FOR LOCATION, REMOVAL AND RELOCATION OF ANY UTILITIES. CONTRACTOR RESPONSIBLE FOR DETERMINING EXTENT AND LOCATION OF UTILITIES. THIS MAY INCLUDE CONTACTING "NO-CUTS" TO HELP LOCATE SOME UTILITIES.
4. CONTRACTOR TO ADJUST ALL MANHOLES, VALVES, JUNCTION BOXES, CATCH BASINS, CLEAN-OUTS, ETC., AS NECESSARY TO ACCOMMODATE NEW LAYOUT AND GRADES.
5. CONTRACTOR RESPONSIBLE FOR OBTAINING ANY PERMITS FOR WORK IN THE NCDOT AND TOWN OF CHAPEL HILL RIGHTS OF WAY. ANY DAMAGED INFRASTRUCTURE IN THE RIGHT OF WAY CAUSED BY CONSTRUCTION ACTIVITIES MUST BE REPAIRED TO TOWN OF CHAPEL HILL STANDARDS. THIS INCLUDES, BUT IS NOT LIMITED TO UTILITIES, SIDEWALKS, CURB AND GUTTER, ASPHALT.
6. CONTRACTOR RESPONSIBLE FOR REMOVING EVERYTHING WITHIN THE CLEARING LIMITS AND OFF-SITE WORK ZONE INCLUDING TREES, STUMPS, TRASH, FENCING, OR BUILDING MATERIALS.
7. CONTRACTOR TO USE CAUTION WORKING AROUND AND NEAR EXISTING STORM, WATER AND SEWER. CONTRACTOR RESPONSIBLE FOR DAMAGE TO EXISTING UTILITIES.
8. ABANDONMENT OF WATER SERVICES SHALL INCLUDE EXCAVATING DOWN TO CORPORATION, TURNING IT OFF AND CUTTING SERVICE LINE FREE FROM CORPORATION. THE METER, IF PRESENT, SHALL BE RETURNED TO OWASA.
9. ABANDONMENT OF SANITARY SEWER SERVICE LINES SHALL CONSIST OF PLUGGING THE LATERAL AT THE RIGHT-OF-WAY LINE.
10. ALL PAVEMENT PATCHING SHALL BE PERFORMED PER CITY SPECIFICATIONS AND STANDARDS.
11. A DECONSTRUCTION ASSESSMENT WILL BE REQUIRED BEFORE A DEMOLITION PERMIT WILL BE ISSUED FOR THE EXISTING 2 STORY STRUCTURE.
12. BY ORANGE COUNTY ORDINANCE, CLEAN WOOD WASTE, SCRAP METAL AND CORRUGATED CARDBOARD, ALL PRESENT IN CONSTRUCTION WASTE, MUST BE RECYCLED.
13. BY ORANGE COUNTY ORDINANCE, ALL HAULERS OF CONSTRUCTION WASTE MUST BE PROPERLY LICENSED.
14. PRIOR TO ANY DEMOLITION OR CONSTRUCTION ACTIVITY ON THE SITE THE APPLICANT WILL HOLD A PRE-DEMOLITION/PRE-CONSTRUCTION CONFERENCE WITH THE COUNTY'S SOLID WASTE STAFF. THIS MAY BE THE SAME MEETING HELD WITH OTHER DEVELOPMENT OFFICIALS.
15. THE PRESENCE OF ANY ASBESTOS CONTAINING MATERIAL ("ACM") OR OTHER HAZARDOUS MATERIALS IN CONSTRUCTION AND DEMOLITION WASTE SHALL BE HANDLED IN ACCORDANCE WITH ANY AND ALL LOCAL, STATE, AND FEDERAL REGULATIONS AND GUIDELINES.
16. A DEMO PERMIT IS REQUIRED TO REMOVE EXISTING BUILDINGS.

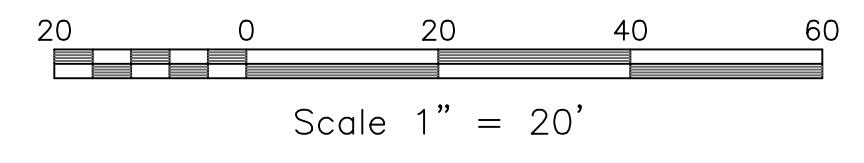

**LEGEND**

Water Valve	⊗	Light Pole	○LP
Curb Inlet/Catch Basin	□	Sewer Cleanout	○CO
Mail Box	Ⓜ	Flored End Section	▭
Traffic Signal Box	Ⓣ	Gas Valve	⊗GV
Electric Transformer	Ⓢ	Existing Iron Pipe (3/4" unless noted)	○IPS
Electric Junction Box	Ⓜ	Existing PK Nail	●PK
Gas Meter	Ⓜ	PK Nail Set	●PKS
Sanitary Sewer Manhole	⊙	Computed Point	△
Storm Sewer Manhole	⊙	Concrete Monument	⊠
Telephone Manhole	⊙	Tree Line	—
Sign	Ⓢ	Fence	—
Telephone Pedestal	Ⓢ	Underground Electric	—
Fire Hydrant	●	Underground Telephone	—
Post Indicator Valve	○PIV	Gas Line	—
Water Manhole	⊙	Water Line	—
Hot Box	Ⓜ	Overhead Utilities	—
Utility Pole	Ⓜ	Storm Sewer	—
		Sanitary Sewer	—
		Guard Rail	—
		Building Wall	—

**Coulter Jewell Thames**  
111 West Main Street  
Durham, N.C. 27701  
p 919.682.0368  
f 919.688.5646  
www.cjtpa.com

Project:  
**324 ROSEMARY MIXED-USE**

324 W ROSEMARY ST.  
CHAPEL HILL, NC 27516

ORANGE COUNTY  
NORTH CAROLINA

PIN: 9788178053

PRELIMINARY  
NOT FOR CONSTRUCTION

Job Number: 1663

Drawn	JSA, ED
Checked	JSA
Date	08.17.2017
Revisions	02.19.2020 COMMENTS
	04.24.2020 COMMENTS

**SITE PLAN**

Sheet Title:  
**EXISTING CONDITIONS, DEMOLITION & TREE PROTECTION PLAN**

Sheet Number:  
**C101**

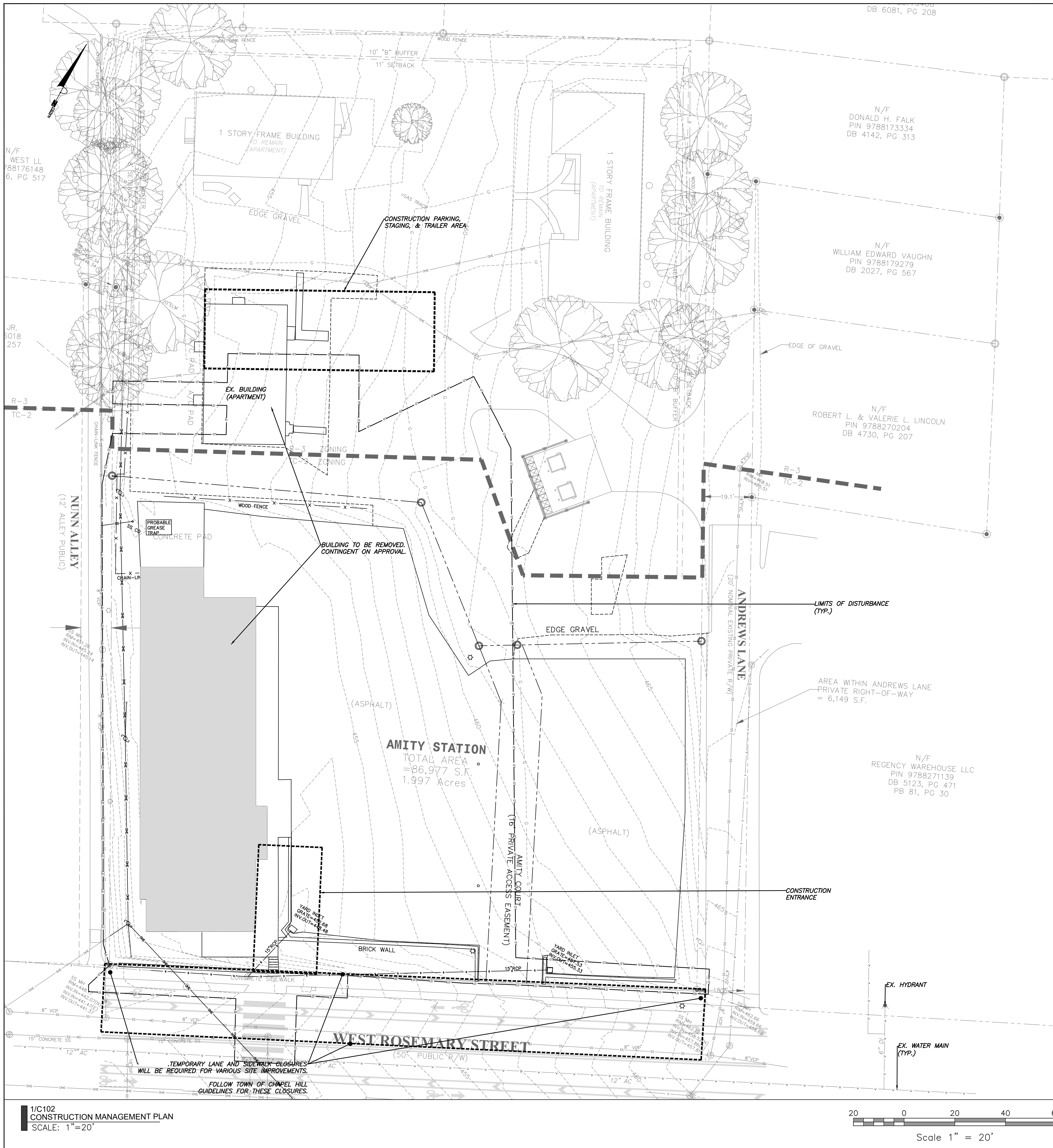

**construction management notes**

1. PROVIDE ONSITE PARKING FOR INSPECTORS AT EACH BUILDING FOR THE DURATION OF THE CONSTRUCTION.
2. PROVIDE A TIRE WASH FOR TRUCKS ONSITE BEFORE THEY HIT THE MAIN ROADS.
3. CURB AND GUTTER AND AT LEAST THE FIRST LIFT OF ASPHALT FOR THE ROADS MUST BE DOWN AHEAD OF CONSTRUCTION.
4. A single electrical service shall be provided to serve the structure with the exception of the fire pump. Article 230.2 (A) 2017 edition of North Carolina Electric Code.
5. A separate submittal and permit will be required for the construction trailer.

**fire notes**

1. NCFC Section 510. Emergency responder radio coverage in new buildings. All new buildings shall have approved radio coverage for emergency responders within the building based upon the existing coverage levels of the public safety communication systems of the jurisdiction of the exterior of the building. This section shall not require improvement of the existing public safety communication systems.
2. PRIVATE FIRE SERVICE MAINS [FIRE SPRINKLER LATERAL(S)]: Private fire service mains and appurtenances shall be installed in accordance with NFPA 24.2018 NCFC Section 507.
3. FDC STANDPIPES: 513.1.1 Where required. In buildings required to have standpipes by Section 905.3.1, not less than one standpipe shall be provided for use during construction. Such standpipes shall be installed prior to construction exceeding 40 feet (12192 mm) in height above the lowest level of fire department vehicle access. Such standpipes shall be provided with fire department vehicle access. Such standpipes shall be extended as construction progresses to within one floor of the highest point of construction having secured decking or flooring. 2018 NCFC Section 513.
4. CONSTRUCTION/DEMOLITION: All Construction and demolition conducted shall be in compliance of the current edition of the NC Fire Code. 2018 NCFC Chapter 33.
5. FIRE WATCH: During construction and demolition where hot work, materials subject to spontaneous combustion, or other hazardous construction or demolition is occurring, the owner or their designee shall be responsible for maintaining a fire watch. The fire watch shall consist of at least one person with a means of communicating an alarm to 911, shall have a written address posted in a conspicuous location, and shall maintain constant patrols. 2018 NCFC Section 3304.
6. FIRE COMMAND CENTER: 508.1 General. Where required by sections of this code and in all buildings classified as a high-rise buildings by the International Building Code, a fire command center for fire department operations shall be provided and shall comply with Sections 508.1.1 through 508.1.6. 2018 NCFC Section 508.
7. FIRE DEPARTMENT CONNECTIONS, INSTALLATION: A working space of not less than 36" in width and depth and a working space of 78" in height shall be provided on all sides with the exception of wall mounted FDCs unless otherwise approved by the fire code official. The FDCs where required must be physically protected by an approved barrier from impacts. 2018 NCFC Section 912.
8. FIRE DEPARTMENT CONNECTIONS, LOCATIONS: Any required FDCs for any buildings shall meet the design and installation requirements for the current, approved edition of NFPA 13, 13D, 13R, or 14 of the NCFC and Town Ordinances; 7-38 for location. FDCs shall be installed on the street/address side of the building and within 100' of a hydrant or unless otherwise approved by the fire code official and shall not be obstructed or hindered by parking or landscaping.
9. FIRE PROTECTION AND UTILITY PLAN: Shall include the fire flow report; for a hydrant within 500' of each building, provide the calculated gallons per minute of water with a residual pressure of 20 pounds per square inch. The calculations shall be sealed by a professional engineer licensed in the State of NC and accompanied by a water supply flow test conducted within one year of the submittal. Reference Town Design Manual for required gallons per minute.
10. WATER SUPPLY FOR FIRE PROTECTION: When required. An approved water supply for fire protection, either temporary or permanent, shall be made available as soon as combustible material arrives on the site. 2018 NCFC 3312.
11. KEY BOXES: 506.1 Where required. Where access to or within a structure or an area is restricted because of secured openings or where immediate access is necessary for life-saving or fire-fighting purposes, the fire code official is authorized to require a key box to be installed in an approved location. The key box shall be of an approved type listed in accordance with UL 1037, and shall contain keys to gain necessary access as required by the fire code official. 2018 NCFC 506.1.
12. ADDRESS IDENTIFICATION: 505.1 Address identification. New and existing buildings shall be provided with approved address identification. The address identification shall be legible and placed in a position that is visible from the street or road front the property. Address identification characters shall contrast with their background. Address numbers shall be Arabic numbers or alphabetical letters. Numbers shall not be spelled out. Each character shall be not less than 6 inches (153 mm) high with a minimum stroke width of 3/4 inch (20 mm). Where required by the fire code official, address identification shall be provided in additional approved locations to facilitate emergency response. Where access is by means of a private road and the building cannot be viewed from the public way, a monument, pole, or other sign or means shall be used to identify the structure. Address identification shall be maintained. 2018 NCFC 505.1.
13. FIRE LANES: Where required by the fire code official, approved signs or other approved notices or markings that include the words NO PARKING-FIRE LANE shall be provided for fire apparatus access roads to identify such roads or prohibit the obstruction thereof. The means by which fire lanes are designated shall be maintained in a clean and legible condition at all times and be replaced or repaired when necessary to provide adequate visibility. 2018 NCFC Section 503.3 and Appendix D D 103.6, D 103.6.1, D 103.6.2.
14. GATES AND BARRICADES: 03.5 Required gates or barricades. The fire code official is authorized to require the installation and maintenance of gates or other approved barricades across fire apparatus access roads, trails, or other accessways; not including public streets, alleys, or highways. Electric gate operators, where provided, shall be listed in accordance with UL 325. Gates intended for automatic operation shall be designed, constructed, and installed to comply with the requirements of ASTM F2200, 2018 NCFC Section 503 and Appendix D103.
15. DEAD END ACCESS ROADS: D103.4 Dead ends. Dead-end fire apparatus access roads in excess of 150 feet (45720 mm) shall be provided with width and turnaround provisions in accordance with Table D 103.4 2018 NCFC Appendix D D103.4.
16. TRAFFIC CALMING DEVICES: Traffic calming devices shall be prohibited unless approved by the fire code official. 2018 NCFC 503.4.1.
17. OBSTRUCTION OF FIRE APPARATUS ACCESS ROADS: Fire apparatus access roads shall not be obstructed in any manner, including the parking of vehicles. The minimum widths and clearances established in Sections 503.2.1 and 503.2.2 shall be maintained at all times. 2018 NCFC 503.4.
18. FIRE DEPARTMENT ACCESS/CONSTRUCTION: During construction, vehicle access for firefighting shall be provided. Temporary street signs shall be installed at each street intersection when construction allows the passage of vehicles. Signs shall be of an approved size, weather resistant, and maintained until replaced by permanent signs. 2018 NCFC Section 505.2.
19. FIRE DEPARTMENT ACCESS/CONSTRUCTION: Fencing around projects shall include access gates with a 20 foot swing or slide motion. Any areas which will be inaccessible for firefighting or rescue operations shall be noted. Emergency access designation for apparatus shall be provided. 2018 NCFC Section 503, Appendix D.
20. FIRE DEPARTMENT ACCESS: All turns, radii, bridges, and depressions within roadways shall be designed and constructed to be accessible by the largest fire apparatus operated by the Town of Chapel Hill. Technical information on this equipment is available from the Towns Fire Marshal. 2018 NCFC Section 503, Appendix D.

Figure 6H-10. Lane Closure on a Two-Lane Road Using Flaggers (TA-10)

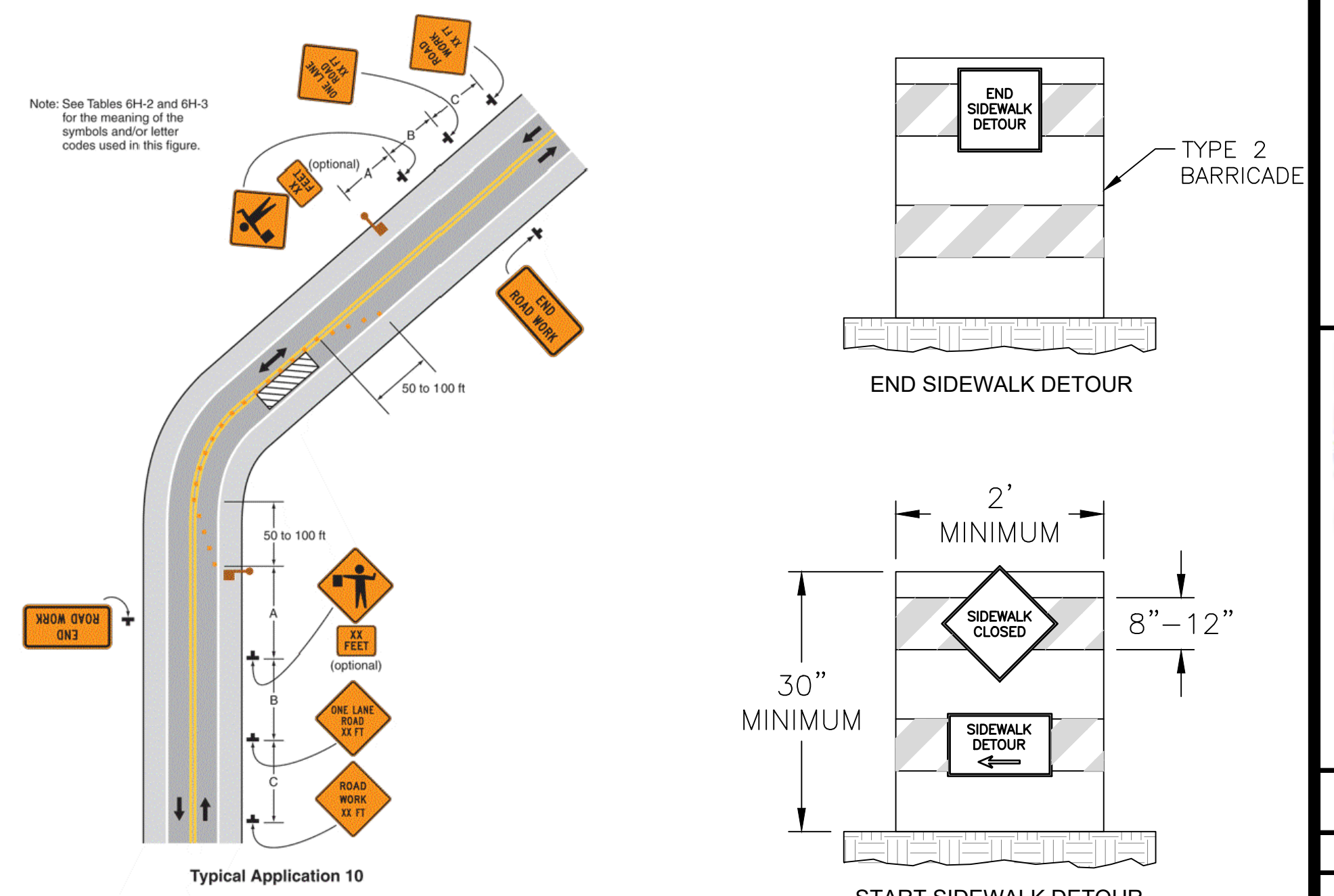

1/C102 NCDOT FIGURE 6H-10 NTS

3/C102 SIDEWALK DETOUR BARRICADES NTS

**LEGEND**

Water Valve	⊗	Light Pole	○LP
Curb Inlet/Catch Basin	□	Sewer Cleanout	○CO
Mail Box	MB	Flared End Section	◁
Traffic Signal Box	TSB	Gas Valve	⊗GV
Electric Transformer	⊞	Existing Iron Pipe (3/4" unless noted)	○IPS
Electric Junction Box	⊞	1/2" Iron Pipe Set	○PK
Gas Meter	⊞	Existing PK Nail	●PK
Sanitary Sewer Manhole	⊞	PK Nail Set	▲PKS
Storm Sewer Manhole	⊞	Computed Point	⊞
Telephone Manhole	⊞	Concrete Monument	⊞
Electric Manhole	⊞	Tree Line	—
Sign	⊞	Fence	—
Telephone Pedestal	⊞	Underground Electric	—
Fire Hydrant	⊞	Underground Telephone	—
Post Indicator Valve	⊞	Gas Line	—
Water Manhole	⊞	Water Line	—
Hot Box	⊞	Overhead Utilities	—
Utility Pole	⊞	Storm Sewer	—
		Sanitary Sewer	—
		Guard Rail	—
		Building Wall	—

**Coulter Jewell Thames**  
 111 West Main Street  
 Durham, N.C. 27701  
 p 919.682.0368  
 f 919.688.5646  
 www.cjtpa.com

Project:  
**324 ROSEMARY MIXED-USE**  
 324 W ROSEMARY ST.  
 CHAPEL HILL, NC 27516  
 ORANGE COUNTY  
 NORTH CAROLINA

PIN: 9788178053

PRELIMINARY  
 NOT FOR CONSTRUCTION  
 Job Number: 1663

Drawn	JSA, ED
Checked	JSA
Date	03/17/2017
Revisions	02/19/2020 COMMENTS
	04/24/2020 COMMENTS

**SITE PLAN**  
 Sheet Title:  
**CONSTRUCTION MANAGEMENT PLAN**  
 Sheet Number  
**C102**

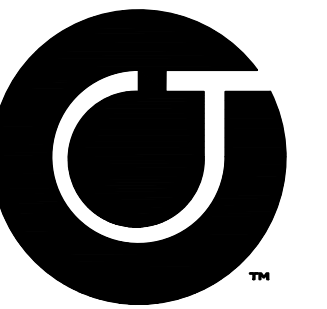

**Coulter  
Jewell  
Thames** P.A.

111 West Main Street  
Durham, N.C. 27701  
p 919.682.0368  
f 919.688.5646  
www.cjtpa.com

Project:

**324 ROSEMARY  
MIXED-USE**

324 W ROSEMARY ST.  
CHAPEL HILL, NC 27516

ORANGE COUNTY  
NORTH CAROLINA

PIN: 9788178053



PRELIMINARY

NOT FOR CONSTRUCTION

Job Number: 1663

Drawn	JSA, ED
Checked	JSA
Date	08/17/2017
Revisions	02/19/2020 COMMENTS
	04/24/2020 COMMENTS

SITE PLAN

Sheet Title:

**EXISTING  
LOTS  
RECOMBINATION**

Sheet Number

**C103**

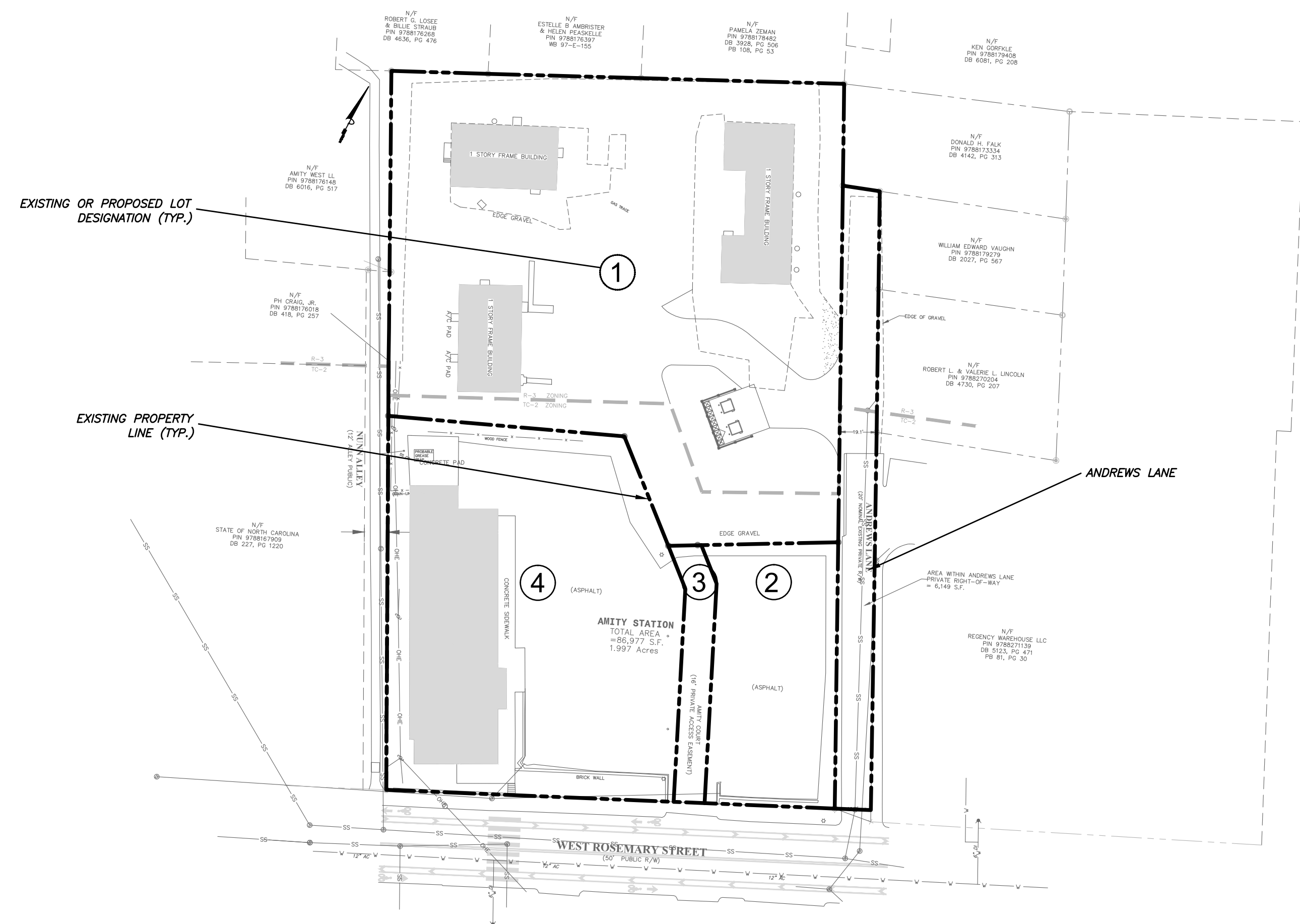

1/C103  
EXISTING LOT CONFIGURATION (4 lots + Andrews Lane)  
SCALE: 1"=50'

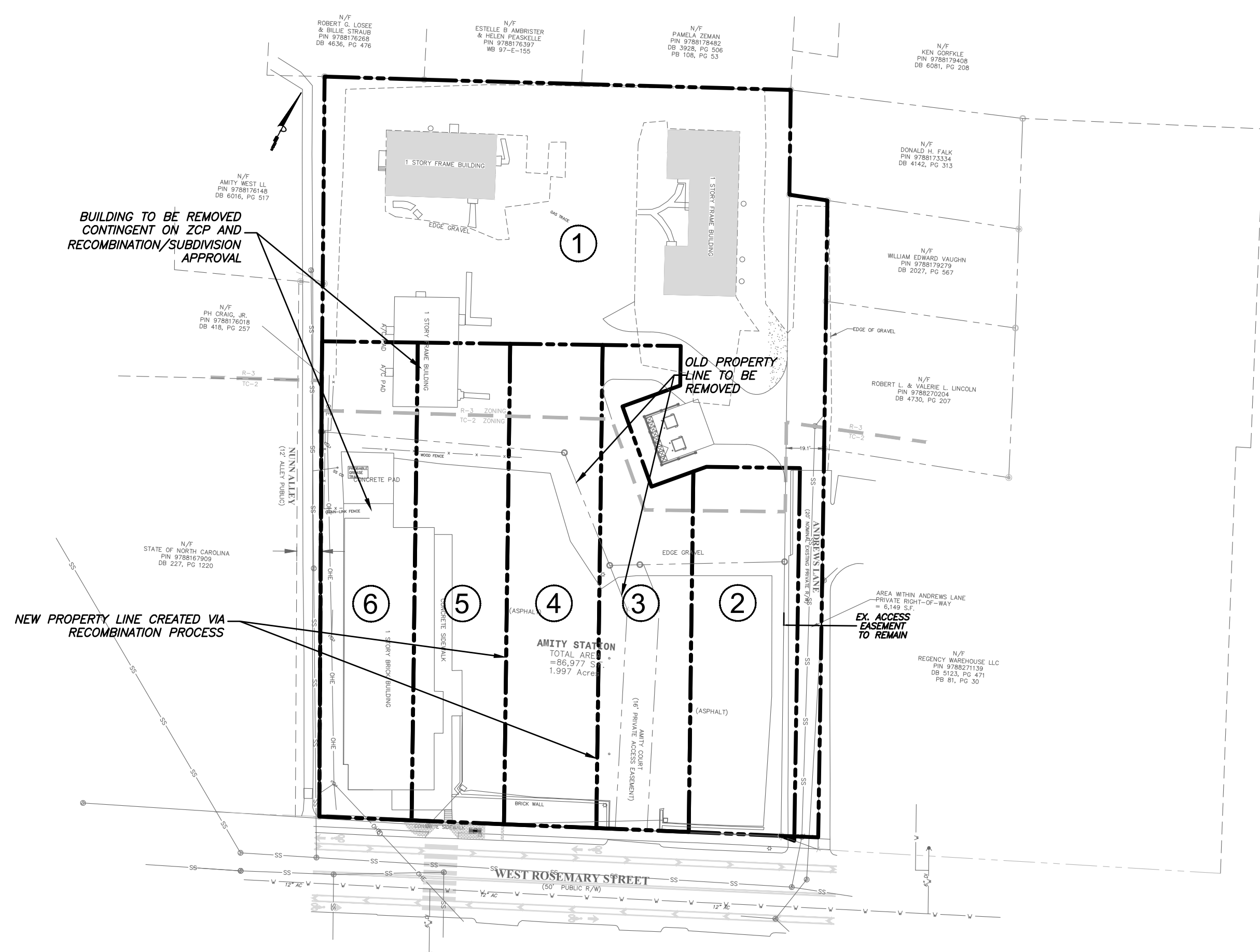

2/C103  
SUBDIVISION CONFIGURATION (6 lots total)  
SCALE: 1"=50'

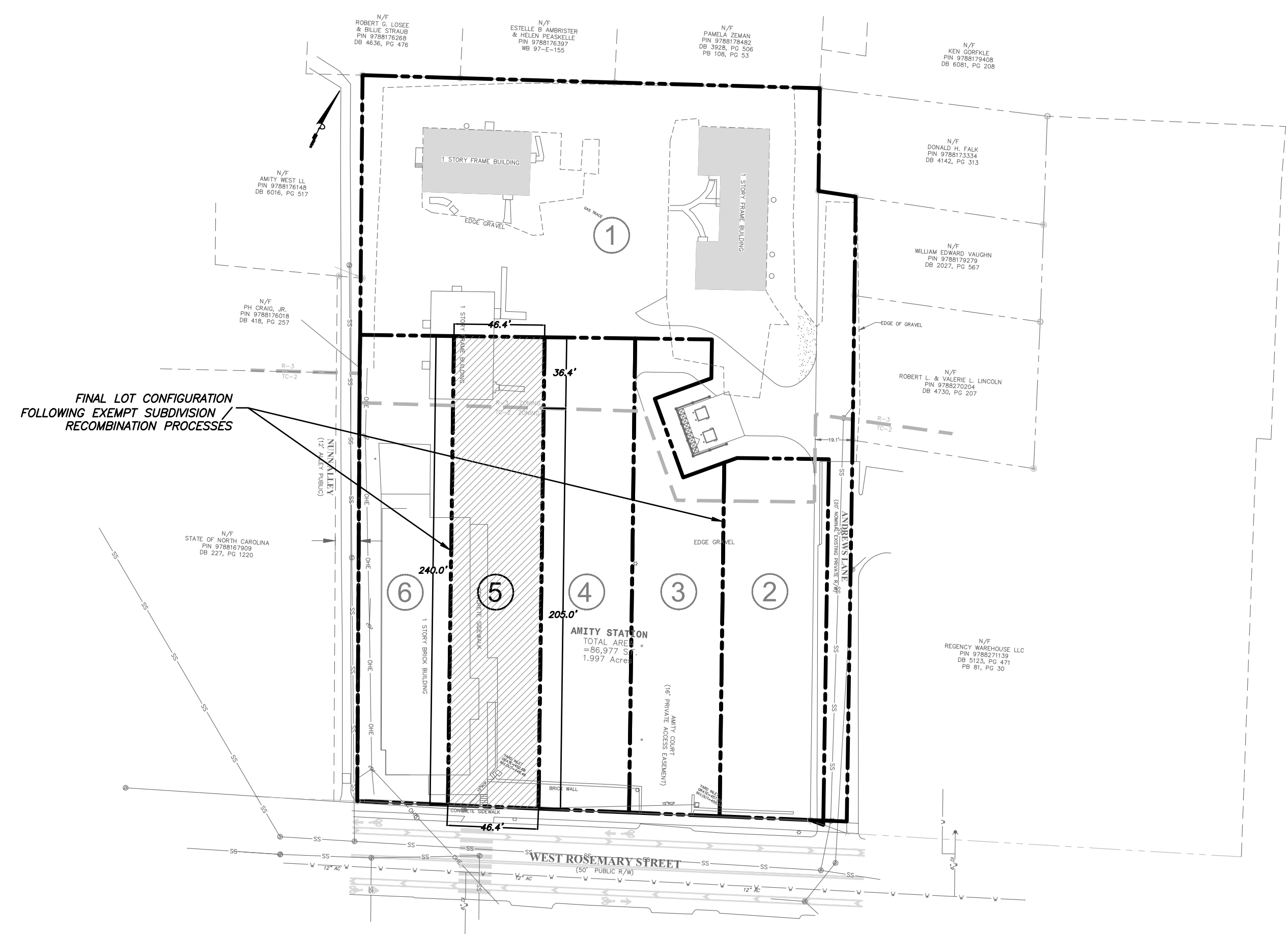

3/C103  
FINAL LOT CONFIGURATION FOR 324 ROSEMARY  
SCALE: 1"=50'

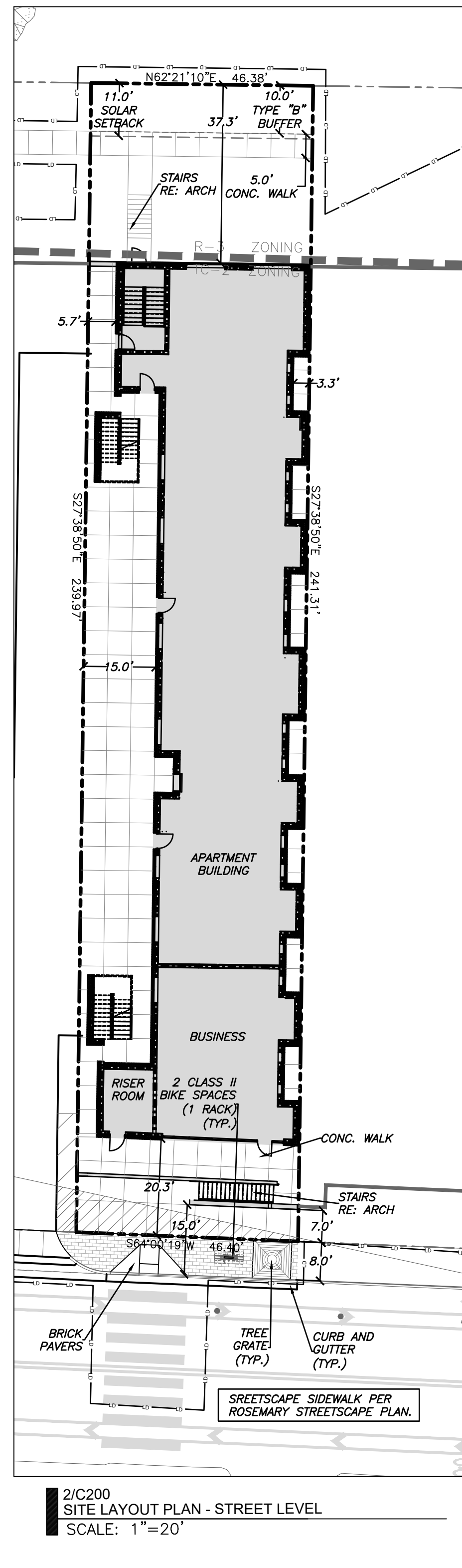
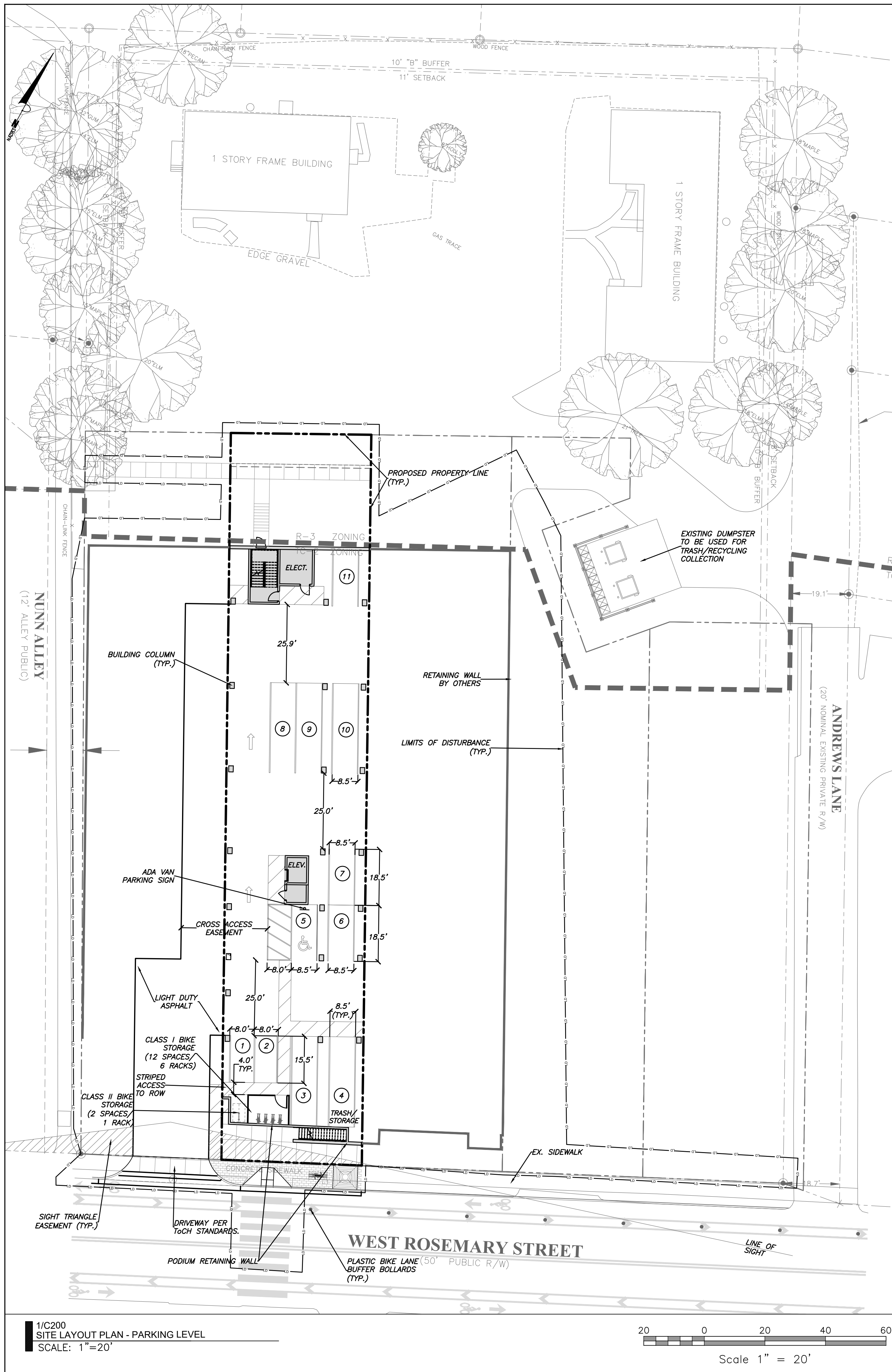

site plan notes

- ALL ANGLES ARE 90 DEGREES UNLESS OTHERWISE NOTED.
- DIMENSIONS TO BUILDING WALL ARE TO FACE OF WALL AT FINISH GRADE. DIMENSIONS TO CURB ARE TO FACE OF CURB.
- LAY OUT IMPROVEMENTS FOR THE CIVIL ENGINEER'S OR LANDSCAPE ARCHITECT'S REVIEW PRIOR TO BEGINNING CONSTRUCTION.
- REFERENCE ARCHITECTURAL DRAWINGS FOR BUILDING LAYOUT INFORMATION. ADA PARKING SPACES SHALL BE SIGNED WITH TYPE R7-B OR R7-BA RESERVED PARKING SIGN AND R7-BD MAXIMUM FINE SIGN PER GS 20-37.6 OF THE NORTH CAROLINA HANDICAP CODE. ADA RAMP SHALL HAVE RAMP SURFACES COVERED WITH DETECTABLE WARNING PATTERN PER ADA STANDARDS.
- REFERENCE EXISTING CONDITION / DEMOLITION PLAN SHEETS C100 FOR EXTENT OF DEMOLITION AND REMOVAL OF CURB AND GUTTER, DRIVEWAYS, PAVEMENT, BOLLARDS, WALKWAYS, UTILITIES, AND VEGETATION.
- BY ORANGE COUNTY ORDINANCE, CLEAN WOOD WASTE, SCRAP METAL AND CORRUGATED CARDBOARD, ALL PRESENT IN CONSTRUCTION WASTE, MUST BE RECYCLED.
- BY ORANGE COUNTY ORDINANCE, ALL HAULERS OF CONSTRUCTION WASTE MUST BE PROPERLY LICENSED.
- PRIOR TO ANY DEMOLITION OR CONSTRUCTION ACTIVITY ON THE SITE THE APPLICANT WILL HOLD A PRE-DEMOLITION/PRE-CONSTRUCTION CONFERENCE WITH THE COUNTY'S SOLID WASTE STAFF. THIS MAY BE THE SAME MEETING HELD WITH OTHER DEVELOPMENT OFFICIALS.
- THE PRESENCE OF ANY ASBESTOS CONTAINING MATERIAL ("ACM") OR OTHER HAZARDOUS MATERIALS IN CONSTRUCTION AND DEMOLITION WASTE SHALL BE HANDLED IN ACCORDANCE WITH ANY AND ALL LOCAL, STATE, AND FEDERAL REGULATIONS AND GUIDELINES.
- MASONRY WALLS WILL NOT BE REPAIRED BY THE TOWN RESULTING FROM MAINTENANCE ON TOWN OF CHAPEL HILL AND OWNERS MAINTAINED UTILITIES.
- TRASH AND RECYCLING WILL BE HANDLED VIA PRIVATE COLLECTION IN A SHARED OFFSITE FACILITY.
- PUBLIC RECYCLING WAIVER:**
  - APPLICANT AGREES TO PROVIDE RECYCLING SERVICES TO RESIDENTS/TENANTS OF THIS PROPERTY IN LIEU OF BUILDING A RECYCLING STATION CONSTRUCTED TO ORANGE COUNTY SPECIFICATIONS. THE SITE WILL NOT RECEIVE PUBLIC RECYCLING COLLECTION NOW OR IN THE FUTURE UNLESS SUCH A RECYCLING STATION IS CONSTRUCTED OR CONTINGENCY FOR SUCH A STATION IS INCLUDED ON THE DEVELOPMENT PLANS.
  - APPLICANT MUST REQUIRE AT LEAST THE SAME LEVEL OF SERVICE (CURRENT OR FUTURE) TO ITS RESIDENTS AS THAT PROVIDED BY ORANGE COUNTY.
  - COUNTY FEES FOR RECYCLING AND WASTE MANAGEMENT ASSOCIATED WITH THIS PROJECT/PROPERTY WILL NOT BE WAIVED.
  - APPLICANT AGREES TO ENTER INTO A SERVICE AGREEMENT WITH A PRIVATE SOLID WASTE RECYCLING COLLECTION CONTRACTOR THAT IS ACCEPTABLE TO ORANGE COUNTY. FURTHER, THE AGREEMENT SHALL PROVIDE FOR THE COLLECTION AND RECYCLING OF CORRUGATED CARDBOARD IN ADDITION TO THE OTHER CO-MINGLED RECYCLABLES AND AN EXECUTED COPY OF THE AGREEMENT SHALL BE PROVIDED TO AND APPROVED BY ORANGE COUNTY PRIOR TO APPROVAL OF FINAL CONSTRUCTION PLANS FOR THE PROPERTY/PROJECT.

site accessibility notes

- ALL PUBLIC SITE ELEMENTS MUST COMPLY WITH NCBC 2018 CH 11 AND ICC A 117.1.
- ACCESSIBLE PARKING PER NCBC SECT 1106.1; 1 PER 6 COMPLIANT SPACES MUST BE VAN ACCESSIBLE, NO SLOPE EXCEEDING 2% IN ANY DIRECTION. SIGNAGE PER NC REQUIREMENTS AND ICC A 117.1.
- CROSS SLOPE ON ACCESSIBLE ROUTES CANNOT EXCEED 2%. SLOPE IN EXCESS OF 5% CONSTITUTES A RAMP, REQUIRING HAND RAILS, GUARDS AND EDGE PROTECTION PER CODE. CROSS SLOPE ON ACCESSIBLE PARKING AND LOADING AREAS NOT TO EXCEED 2%. CALL FOR INSPECTION BEFORE PLACEMENT OF ANY CONCRETE. ALL PUBLIC ACCESS SITE FEATURES MUST MEET ICC/ANSI A117.1.
- ACCESSIBILITY REQUIREMENTS: THAT PRIOR TO ISSUANCE OF A CERTIFICATE OF OCCUPANCY, THE APPLICANT SHALL PROVIDE THE MINIMUM REQUIRED HANDICAPPED PARKING SPACES AND DESIGN ALL HANDICAPPED PARKING SPACES, RAMPS, AND CROSSWALKS, AND ASSOCIATED INFRASTRUCTURE ACCORDING TO AMERICANS WITH DISABILITIES ACT STANDARDS; NORTH CAROLINA BUILDING CODE, AMERICAN NATIONAL STANDARDS INSTITUTE (ANSI) CODE, AND TOWN STANDARD.
  - PARKING - NUMBER OF SPACES TO COMPLY WITH NCBC 2018 SECTION 1106.1, 1 PER 6 COMPLIANT SPACES OR PORTION THEREOF MUST BE VAN ACCESSIBLE, NO SLOPE TO EXCEED 2% IN ANY DIRECTION. SIGNAGE PER NC REQUIREMENTS, MUT-CD AND ICC A 117.1.
  - CURB CUTS AND ACCESSIBLE ROUTES PER ICC A117.1 2009 ED, CROSS SLOPE LIMITED TO 2%, CALL FOR INSPECTION BEFORE PLACEMENT OF CONCRETE.
  - SLOPE GREATER THAN 5% REQUIRES CONSTRUCTION AS A RAMP.

fire notes

- ALL PUBLIC SITE ELEMENTS MUST COMPLY WITH NCBC 2018 CH 11 AND ICC A 117.1.
- ACCESSIBLE PARKING PER NCBC SECT 1106.1; 1 PER 6 COMPLIANT SPACES MUST BE VAN ACCESSIBLE, NO SLOPE EXCEEDING 2% IN ANY DIRECTION. SIGNAGE PER NC REQUIREMENTS AND ICC A 117.1.
- CROSS SLOPE ON ACCESSIBLE ROUTES CANNOT EXCEED 2%. SLOPE IN EXCESS OF 5% CONSTITUTES A RAMP, REQUIRING HAND RAILS, GUARDS AND EDGE PROTECTION PER CODE. CROSS SLOPE ON ACCESSIBLE PARKING AND LOADING AREAS NOT TO EXCEED 2%. CALL FOR INSPECTION BEFORE PLACEMENT OF ANY CONCRETE. ALL PUBLIC ACCESS SITE FEATURES MUST MEET ICC/ANSI A117.1.
- ACCESSIBILITY REQUIREMENTS: THAT PRIOR TO ISSUANCE OF A CERTIFICATE OF OCCUPANCY, THE APPLICANT SHALL PROVIDE THE MINIMUM REQUIRED HANDICAPPED PARKING SPACES AND DESIGN ALL HANDICAPPED PARKING SPACES, RAMPS, AND CROSSWALKS, AND ASSOCIATED INFRASTRUCTURE ACCORDING TO AMERICANS WITH DISABILITIES ACT STANDARDS; NORTH CAROLINA BUILDING CODE, AMERICAN NATIONAL STANDARDS INSTITUTE (ANSI) CODE, AND TOWN STANDARD.
  - PARKING - NUMBER OF SPACES TO COMPLY WITH NCBC 2018 SECTION 1106.1, 1 PER 6 COMPLIANT SPACES OR PORTION THEREOF MUST BE VAN ACCESSIBLE, NO SLOPE TO EXCEED 2% IN ANY DIRECTION. SIGNAGE PER NC REQUIREMENTS, MUT-CD AND ICC A 117.1.
  - CURB CUTS AND ACCESSIBLE ROUTES PER ICC A117.1 2009 ED, CROSS SLOPE LIMITED TO 2%, CALL FOR INSPECTION BEFORE PLACEMENT OF CONCRETE.
  - SLOPE GREATER THAN 5% REQUIRES CONSTRUCTION AS A RAMP.

LEGEND

Water Valve	Light Pole	O LP
Curb Inlet/Catch Basin	Sewer Cleanout	O CO
Mail Box	Flared End Section	□
Traffic Signal Box	Gas Valve	⊗ GV
Electric Transformer	Existing Iron Pipe (3/4" unless noted)	○ IPS
Electric Junction Box	1/2" Iron Pipe Set	○ PK
Gas Meter	Existing PK Nail	⊗ PKS
Sanitary Sewer Manhole	Computed Point	△
Storm Sewer Manhole	Concrete Monument	⊠
Telephone Manhole	Tree Line	~~~~~
Sign	Fence	— — — — —
Telephone Pedestal	Underground Electric	— — — — —
Fire Hydrant	Underground Telephone	— — — — —
Water Manhole	Water Line	— — — — —
Water Meter	Overhead Utilities	— — — — —
Hot Box	Sanitary Sewer	— — — — —
Utility Pole	Guard Rail	— — — — —
	Building Wall	— — — — —

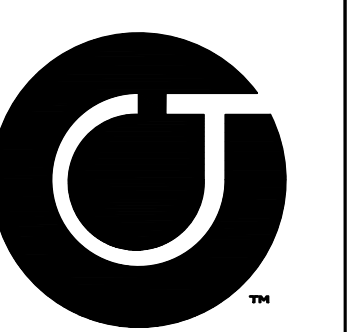

Coulter Jewell Thames P.A.

111 West Main Street  
Durham, N.C. 27701  
p 919.682.0368  
f 919.688.5646  
www.cjtpa.com

Project:

322 ROSEMARY MIXED-USE

322 W ROSEMARY ST.  
CHAPEL HILL, NC 27516

ORANGE COUNTY  
NORTH CAROLINA

PIN: 9788178053

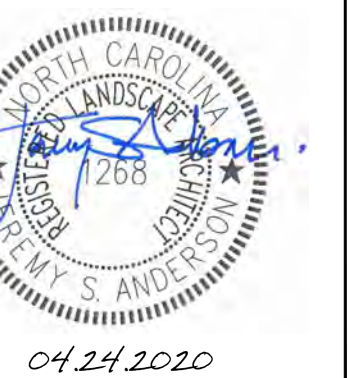

PRELIMINARY  
NOT FOR CONSTRUCTION

Job Number: 1663

Drawn	JSA, ED
Checked	JSA
Date	08.17.2017
Revisions	02.19.2020 COMMENTS
	04.24.2020 COMMENTS

SITE PLAN

Sheet Title:

SITE LAYOUT PLAN

Sheet Number  
C200

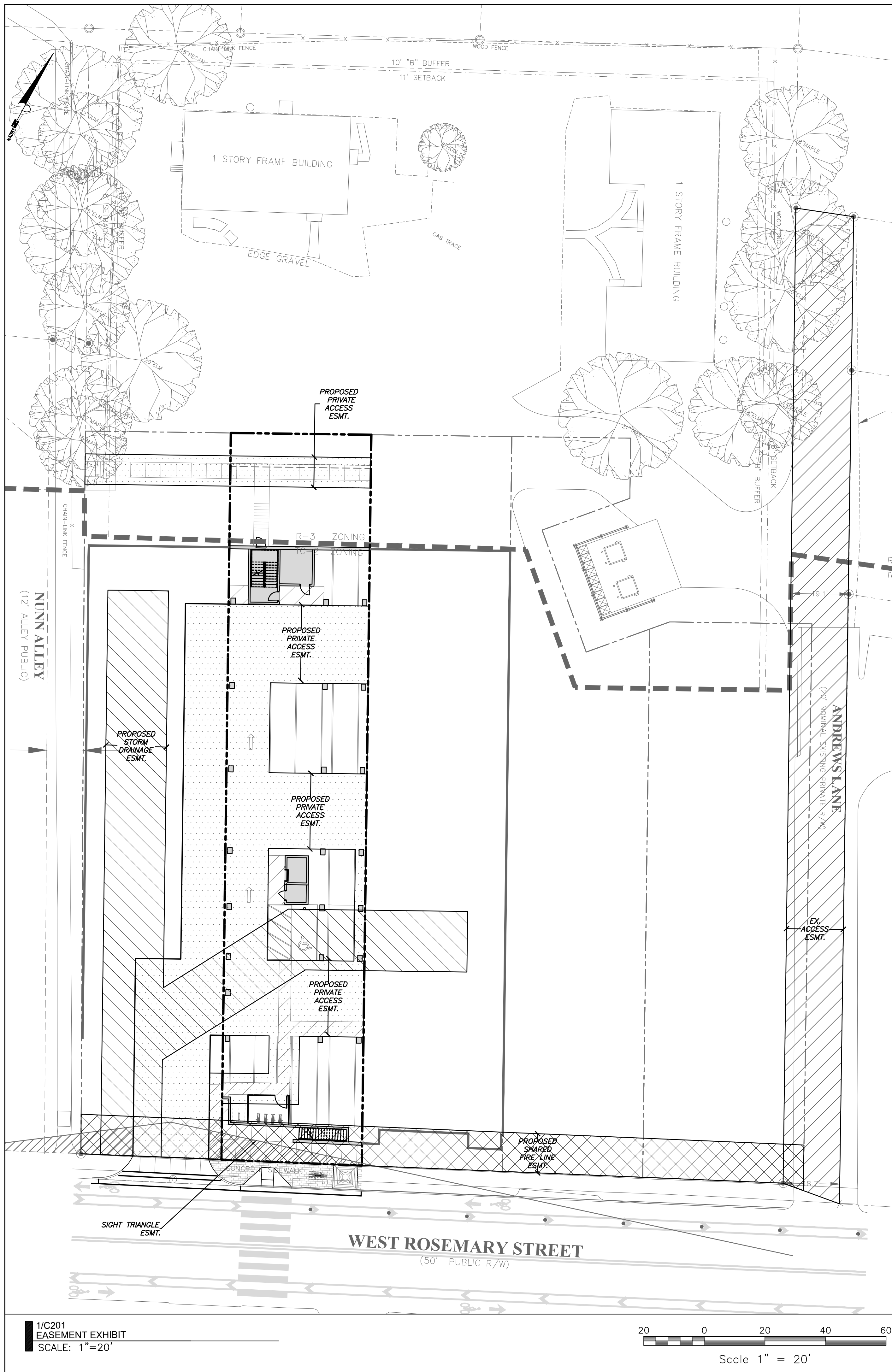

1/C201  
EASEMENT EXHIBIT  
SCALE: 1"=20'

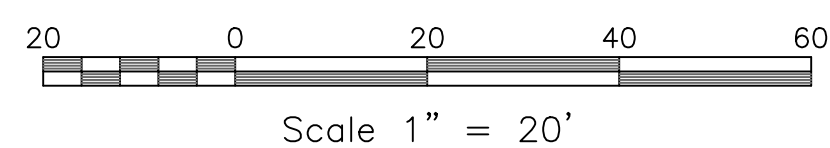

**LEGEND**

Water Valve	⊗	Light Pole	○LP
Curb Inlet/Catch Basin	□	Sewer Cleanout	○CO
Mail Box	MB	Flared End Section	▭
Traffic Signal Box	⊠TSB	Gas Valve	⊗GV
Electric Transformer	⊠	Existing Iron Pipe (3/4" unless noted)	○IPS
Electric Junction Box	⊠	1/2" Iron Pipe Set	○PK
Gas Meter	⊠	Existing PK Nail	●PKS
Sanitary Sewer Manhole	⊙	PK Nail Set	●PKS
Storm Sewer Manhole	⊙	Computed Point	△
Telephone Manhole	⊙	Concrete Monument	⊠
Electric Manhole	⊙	Tree Line	~~~~~
Sign	⊠	Fence	— — — — —
Telephone Pedestal	⊠TZL	Underground Electric	— — — — —
Fire Hydrant	●	Underground Telephone	— — — — —
Post Indicator Valve	○PIV	Water Line	— — — — —
Water Manhole	⊙	Overhead Utilities	— — — — —
Water Meter	⊠	Storm Sewer	— — — — —
Hot Box	⊠	Sanitary Sewer	— — — — —
Utility Pole	⊠	Guard Rail	— — — — —
		Building Wall	▭

**Coulter  
Jewell  
Thames**  
RA

111 West Main Street  
Durham, N.C. 27701  
p 919.682.0368  
f 919.688.5646  
www.cjtpa.com

Project:  
**322 ROSEMARY  
MIXED-USE**

322 W ROSEMARY ST.  
CHAPEL HILL, NC 27516

ORANGE COUNTY  
NORTH CAROLINA

PIN: 9788178053



PRELIMINARY  
NOT FOR CONSTRUCTION

Job Number: 1663

Drawn	JSA, ED
Checked	JSA
Date	08.17.2017
Revisions	02.19.2020 COMMENTS
	04.24.2020 COMMENTS

SITE PLAN  
Sheet Title:

**EASEMENT  
EXHIBIT**

Sheet Number  
**C201**

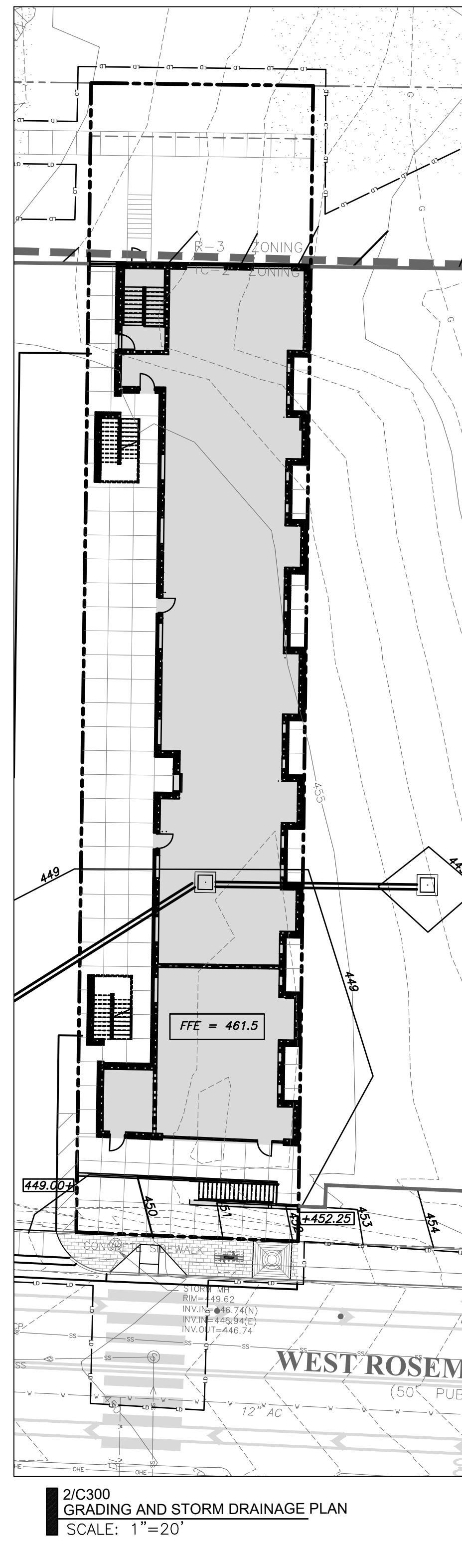
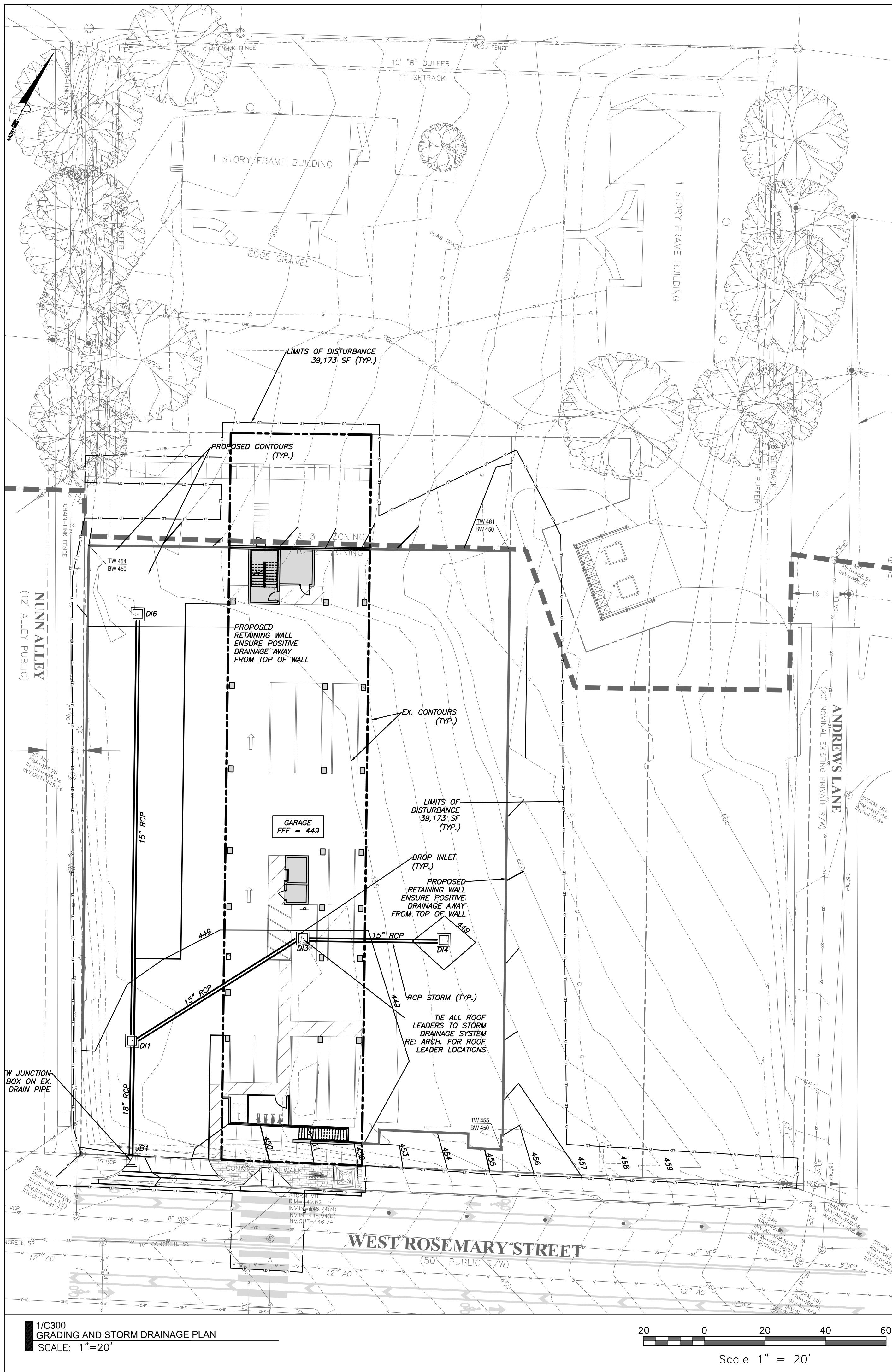

**grading and storm drainage notes**

**GRADING NOTES:**

1. ALL DIMENSIONS AND GRADES SHOWN ON THE PLANS SHALL BE FIELD VERIFIED BY THE CONTRACTOR PRIOR TO CONSTRUCTION. CONTRACTOR SHALL NOTIFY THE OWNER IF ANY DISCREPANCIES EXIST PRIOR TO PROCEEDING WITH CONSTRUCTION FOR NECESSARY PLAN OR GRADE CHANGES. NO EXTRA COMPENSATION SHALL BE PAID TO THE CONTRACTOR FOR ANY WORK DONE DUE TO DIMENSIONS OR GRADES SHOWN INCORRECTLY ON THESE PLANS IF SUCH NOTIFICATION HAS NOT BEEN GIVEN.
2. ALL CONSTRUCTION SHALL BE IN ACCORDANCE WITH TOWN OF CHAPEL HILL STANDARDS AND SPECIFICATIONS.
3. CONTRACTOR SHALL NOTIFY "NORTH CAROLINA ONE CALL" (1-800-632-4949) AT LEAST 48 HOURS PRIOR TO BEGINNING CONSTRUCTION OR EXCAVATION TO HAVE EXISTING UTILITIES LOCATED. CONTRACTOR TO CONTACT ANY LOCAL UTILITIES THAT PROVIDE THEIR OWN LOCATOR SERVICES INDEPENDENT OF "NORTH CAROLINA ONE CALL".
4. CONSTRUCTION, MAINTENANCE AND REMOVAL OF ALL EROSION CONTROL DEVICES ARE THE RESPONSIBILITY OF THE GENERAL CONTRACTOR.
5. EXISTING UTILITIES AND STRUCTURES SHOWN, BOTH UNDERGROUND AND ABOVE GROUND, ARE BASED ON A FIELD SURVEY AND THE BEST AVAILABLE RECORD DRAWINGS. THE CONTRACTOR SHALL VERIFY FIELD CONDITIONS PRIOR TO BEGINNING RELATED CONSTRUCTION. ANY DISCREPANCIES SHALL BE REPORTED TO THE OWNER'S REPRESENTATIVE IMMEDIATELY.
6. SOIL UNDER BUILDING PAD, PAVED AREAS AND WITHIN SLOPES GREATER THAN 3:1 (H:V) SHALL BE APPROVED, PLACED AND COMPACTED AS RECOMMENDED BY THE GEOTECHNICAL ENGINEER. THESE SOILS SHALL BE COMPACTED AS SPECIFIED UNLESS OTHERWISE RECOMMENDED BY THE GEOTECHNICAL ENGINEER. ANY UNDERCUT SOILS IN THESE AREAS SHALL BE APPROVED BY THE GEOTECHNICAL ENGINEER & OWNER. THE UNDERCUT SOILS SHALL ALSO QUANTIFIED BY THE GEOTECHNICAL ENGINEER.
7. ALL GRADING MUST PRODUCE SURFACE DRAINAGE ADEQUATE TO PREVENT STANDING WATER OR WET LAWN AREAS, AND TO ENSURE THAT ALL STORM WATER FLOWS TO INLETS OR OTHER POINTS OF DISCHARGE.
8. ALL SIDEWALKS SHALL BE CONSTRUCTED WITH A MAXIMUM 1.8% CROSS SLOPE IN THE DIRECTION SHOWN ON THE PLAN.
9. CONNECT ALL ROOF LEADERS AND DOWNSPOUTS TO STORM DRAINAGE SYSTEM WITH PVC PIPE. SEE ARCHITECTURAL PLANS FOR LOCATIONS.
10. CURB INLETS: PROVIDE PRE-CAST CURB INLET HOODS AND COVERS STATING, "DUMP NO WASTE! DRAINS TO JORDAN LAKE" IN ACCORDANCE WITH THE SPECIFICATIONS OF THE TOWN STANDARD DETAIL SD-5A, FOR ALL NEW CURB INLETS FOR PRIVATE, TOWN AND STATE RIGHTS-OF-WAY.

**STORM DRAINAGE NOTES:**

1. ALL STORM DRAINAGE PIPES SHOWN ARE TO BE CLASS III REINFORCED CONCRETE (RCP) UNLESS NOTED OTHERWISE.
2. ALL STORM DRAINAGE CONSTRUCTION SHALL BE IN ACCORDANCE WITH THE TOWN OF CHAPEL HILL STANDARDS.
3. ALL CONCRETE SHALL MEET A MINIMUM 3000 PSI COMPRESSIVE STRENGTH.
4. ALL PIPE IN STORM DRAIN STRUCTURES SHALL BE STRUCK EVEN WITH INSIDE WALL.
5. ALL PIPE JOINTS SHALL BE MADE WITH PREFORMED JOINT SEALER, WHICH CONFORMS TO AASHTO SPECIFICATION M-198 FOR TYPE B FLEXIBLE PLASTIC GASKETS UNLESS OTHERWISE NOTED.
6. THE INTERIOR SURFACES OF ALL STORM DRAINAGE STRUCTURES SHALL BE POINTED AND SMOOTHED TO AN ACCEPTABLE STANDARD USING MORTAR MIXED TO MANUFACTURER'S SPECIFICATIONS.
7. ALL BACKFILL SHALL BE NON-PLASTIC IN NATURE, FREE FROM ROOTS, VEGETATION MATTER, WASTE CONSTRUCTION MATERIAL OR OTHER OBJECTIONABLE MATERIAL. SAID MATERIAL SHALL BE CAPABLE OF BEING COMPACTED BY MECHANICAL MEANS AND SHALL HAVE NO TENDENCY TO FLOW OR BEHAVE IN A PLASTIC MANNER UNDER THE TAMPING BLOWS OR PROOF ROLLING.
8. MATERIALS DEEMED BY THE OWNER'S REPRESENTATIVE AS UNSUITABLE FOR BACKFILL PURPOSES SHALL BE REMOVED AND REPLACED WITH SUITABLE MATERIAL.
9. BACKFILLING OF TRENCHES SHALL BE ACCOMPLISHED IMMEDIATELY AFTER PIPE IS LAID. THE FILL AROUND THE PIPE SHALL BE THOROUGHLY COMPACTED TO 95% OF THE MAXIMUM DRY DENSITY OBTAINABLE WITH THE STANDARD PROCTOR TEST. THE TOP EIGHT (8) INCHES SHALL BE COMPACTED TO 100% STANDARD PROCTOR.
10. UNDER NO CIRCUMSTANCES SHALL WATER BE ALLOWED TO RISE IN UNBACKFILLED TRENCHES AFTER PIPE HAS BEEN PLACED.
11. CONNECT ALL ROOF LEADERS AND DOWNSPOUTS TO STORM DRAINAGE SYSTEM WITH PVC PIPE. SEE ARCHITECTURAL PLANS FOR LOCATIONS.

**erosion control notes**

**EROSION CONTROL NOTES:**

1. EROSION CONTROL BOND: IF ONE (1) ACRE OR MORE IS UNCOVERED BY LAND-DISTURBING ACTIVITIES FOR THIS PROJECT, THEN A PERFORMANCE GUARANTEE IN ACCORDANCE WITH SECTION 5-97.1 BONDS OF THE TOWN CODE OF ORDINANCES SHALL BE REQUIRED PRIOR TO FINAL AUTHORIZATION TO BEGIN LAND-DISTURBING ACTIVITIES. THIS FINANCIAL GUARANTEE IS INTENDED TO COVER THE COSTS OF RESTORATION OF FAILED OR FAILING SOIL EROSION AND SEDIMENTATION CONTROLS, AND/OR TO REMEDY DAMAGES RESULTING FROM LAND-DISTURBING ACTIVITIES, SHOULD THE RESPONSIBLE PARTY OR PARTIES FAIL TO PROVIDE PROMPT AND EFFECTIVE REMEDIES ACCEPTABLE TO THE TOWN.
2. THE APPLICANT SHALL PROVIDE A COPY OF THE APPROVED EROSION AND SEDIMENT CONTROL PERMIT FROM ORANGE COUNTY EROSION CONTROL DIVISION PRIOR TO RECEIVING A ZONING COMPLIANCE PERMIT. DURING THE CONSTRUCTION PHASE, ADDITIONAL EROSION AND SEDIMENT CONTROLS MAY BE REQUIRED IF THE PROPOSED MEASURES DO NOT CONTAIN THE SEDIMENT. SEDIMENT LEAVING THE PROPERTY IS A VIOLATION OF THE TOWN'S EROSION AND SEDIMENT CONTROL ORDINANCE.
3. THE CONTRACTOR SHALL TAKE THE APPROPRIATE MEASURES TO PREVENT AND REMOVE THE DEPOSIT OF WET OR DRY SILT ON ADJACENT PAVED ROADWAYS.
4. EROSION CONTROL INSPECTIONS: IN ADDITION TO THE REQUIREMENT DURING CONSTRUCTION FOR INSPECTION AFTER EVERY RAINFALL, THE APPLICANT SHALL INSPECT THE EROSION AND SEDIMENT CONTROL DEVICES WEEKLY, MAKE ANY NECESSARY REPAIRS OR ADJUSTMENTS TO THE DEVICES, AND MAINTAIN INSPECTION LOGS DOCUMENTING THE DAILY INSPECTIONS AND ANY NECESSARY REPAIRS.

**building height - grade calculation**

AVERAGE STREET GRADE = 450.625

**LEGEND**

Water Valve	⊗	Light Pole	⊙LP
Curb Inlet/Catch Basin	⊠	Sewer Cleanout	⊙CO
Mail Box	⊠MB	Flored End Section	⊠
Traffic Signal Box	⊠TSB	Gas Valve	⊗GV
Electric Transformer	⊠ET	Existing Iron Pipe (3/4" unless noted)	⊙IPS
Electric Junction Box	⊠EJB	1/2" Iron Pipe Set	⊙PK
Gas Meter	⊠GM	Existing PK Nail	⊙PKS
Sanitary Sewer Manhole	⊙SSM	PK Nail Set	⊙PKS
Storm Sewer Manhole	⊙SSM	Computed Point	⊠
Telephone Manhole	⊙TM	Concrete Monument	⊠
Electric Manhole	⊙EM	Tree Line	⊠
Sign	⊠	Fence	⊠
Telephone Pedestal	⊠TEL	Underground Electric	⊠
Fire Hydrant	⊙FH	Underground Telephone	⊠
Post Indicator Valve	⊙PIV	Gas Line	⊠
Water Manhole	⊙WM	Water Line	⊠
Water Meter	⊙WM	Overhead Utilities	⊠
Hot Box	⊠HB	Storm Sewer	⊠
Utility Pole	⊠	Sanitary Sewer	⊠
		Guard Rail	⊠
		Building Wall	⊠

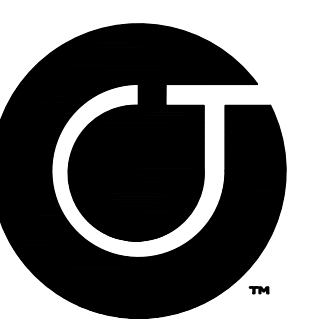

**Coulter Jewell Thames**  
ARCHITECTURE

111 West Main Street  
Durham, N.C. 27701  
p 919.682.0368  
f 919.688.5646  
www.cjtpa.com

Project:

**324 ROSEMARY MIXED-USE**

324 W ROSEMARY ST.  
CHAPEL HILL, NC 27516

ORANGE COUNTY  
NORTH CAROLINA

PIN: 9788178053



PRELIMINARY  
NOT FOR CONSTRUCTION

Job Number: 1663

Drawn	JSA, ED
Checked	JSA
Date	08.17.2017
Revisions	02.19.2020 COMMENTS
	04.24.2020 COMMENTS

SITE PLAN

Sheet Title:

**GRADING AND STORM DRAINAGE PLAN**

Sheet Number

**C300**



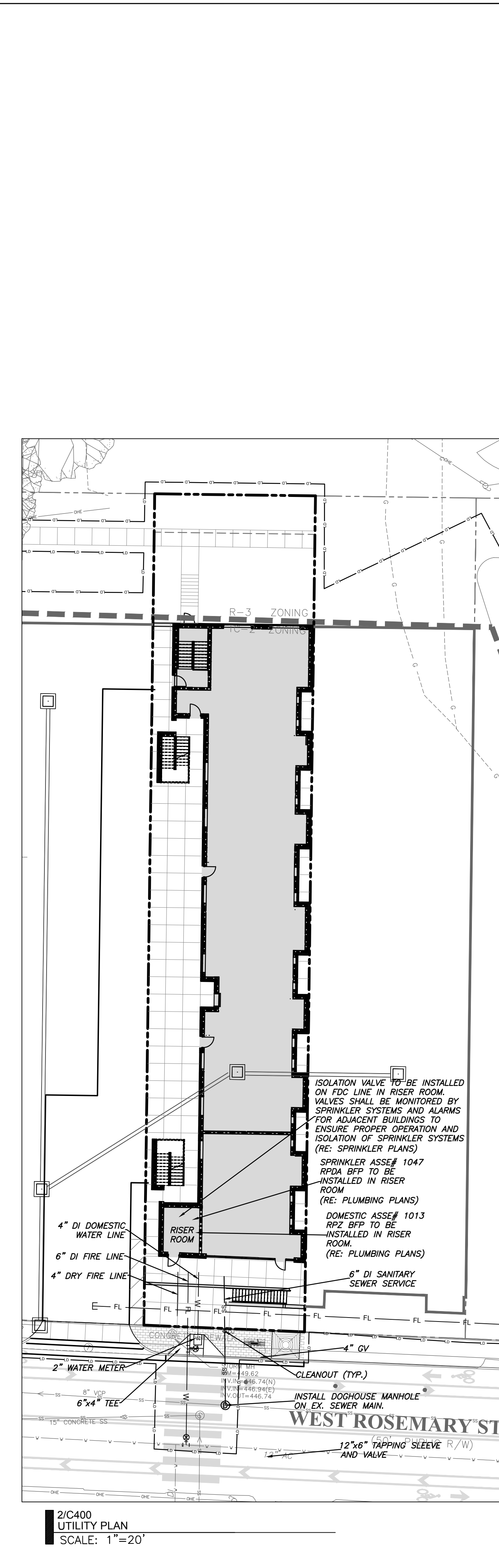
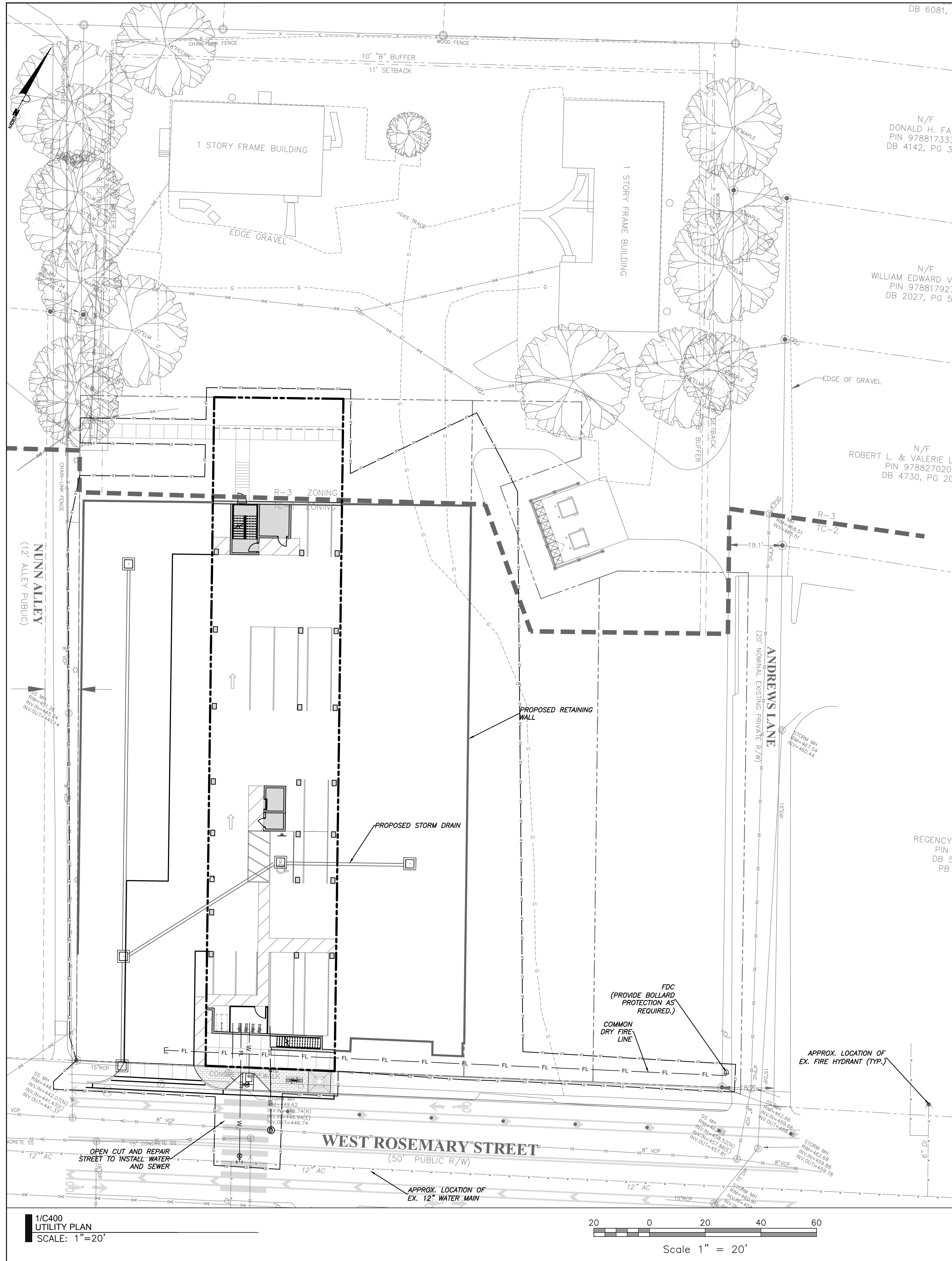

utility notes

GENERAL NOTES:

- CONTRACTOR SHALL NOTIFY "NORTH CAROLINA ONE CALL" (1-800-632-4949) AT LEAST 48 HOURS PRIOR TO BEGINNING CONSTRUCTION OR EXCAVATION TO HAVE EXISTING UTILITIES LOCATED. CONTRACTOR TO CONTACT ANY LOCAL UTILITIES THAT PROVIDE THEIR OWN LOCATOR SERVICE INDEPENDENT OF "NORTH CAROLINA ONE CALL".
- ALL WATER AND SEWER MAINS WITHIN PUBLIC EASEMENTS AND RIGHT-OF-WAYS TO BE OWNED, OPERATED AND MAINTAINED BY THE TOWN OF CHAPEL HILL.
- ALL CONSTRUCTION SHALL BE IN ACCORDANCE WITH THE TOWN OF CHAPEL HILL STANDARDS AND SPECIFICATIONS.
- ALL EXISTING UNDERGROUND UTILITIES ARE APPROXIMATELY LOCATED. ACTUAL LOCATION AND DEPTH SHALL BE CONFIRMED IN THE FIELD PRIOR TO CONSTRUCTION.
- BEFORE STARTING ANY CONSTRUCTION OF IMPROVEMENTS WITHIN ANY TOWN OR N.C.D.O.T. STREET OR HIGHWAY RIGHT-OF-WAY THE FOLLOWING PROCEDURES SHOULD BE UNDERTAKEN: TOWN RIGHT-OF-WAY: CONTACT LOCAL AUTHORITIES' TRAFFIC ENGINEERING DEPT. FOR INFORMATION ON DETOURS, OPEN CUTTING OF STREETS OR FOR ANY CONSTRUCTION WITHIN RIGHT-OF-WAY. N.C.D.O.T. RIGHT-OF-WAY: CONTACT PROJECT ENGINEERS AND OBTAIN ALL PERMITS AND ENCROACHMENTS (KEEP COPIES ON CONSTRUCTION SITE, ALSO CONTACT N.C.D.O.T. DISTRICT OFFICE 24 HOURS IN ADVANCE BEFORE PLACING CURB AND GUTTER).
- ALL DIMENSIONS AND GRADES SHOWN ON THE PLANS SHALL BE FIELD VERIFIED BY THE CONTRACTOR PRIOR TO CONSTRUCTION. CONTRACTOR SHALL NOTIFY THE OWNER IF ANY DISCREPANCIES EXIST. PRIOR TO PROCEEDING WITH CONSTRUCTION FOR NECESSARY PLAN OR GRADING CHANGES. NO EXTRA COMPENSATION SHALL BE PAID TO THE CONTRACTOR FOR ANY WORK DONE DUE TO DIMENSIONS OR GRADES SHOWN INCORRECTLY ON THESE PLANS IF SUCH NOTIFICATION HAS NOT BEEN GIVEN.
- POWER, TELEPHONE, AND GAS SERVICES TO BUILDINGS SHALL BE UNDERGROUND. ACCESS AND SERVICE ROUTES TO BE COORDINATED WITH THE PUBLIC UTILITIES, CONTRACTOR AND THE OWNER.
- RESURFACING OF STREET DUE TO UTILITY CUTS SHALL BE REQUIRED AT THE DIRECTION OF ENGINEERING. (MINIMUM 50' TO EITHER SIDE OF UTILITY CUTS).
- IF THERE WILL BE ANY:
  - FLOOR DRAINS FROM INTERIOR PARKING AREAS,
  - DRAINS FROM HYDRAULIC ELEVATOR SHAFTS
 SHALL CONNECT TO SANITARY SEWER AND INCLUDE OIL WATER SEPARATORS.

SANITARY SEWER:

- BACKFLOW PREVENTORS SHALL BE PROVIDED FOR ALL UNITS WITH FINAL FLOOR ELEVATIONS OF BUILDINGS LESS THAN 1'-0" ABOVE UPSTREAM MANHOLE.
- MINIMUM COVER OF 5 FEET IN TRAFFIC AREAS TO BE PROVIDED FOR ALL COLLECTOR LINES 4 INCHES AND LARGER. IF LESS THAN 5 FEET, DUCTILE IRON PIPE SHALL BE REQUIRED.
- MINIMUM SLOPE FOR 4 INCH SANITARY SEWER COLLECTION LINES SHALL BE NO LESS THAN 2.0% WITH CLEANOUTS EVERY 75 LINEAL FEET.
- MINIMUM SLOPE FOR 6 INCH SANITARY SEWER COLLECTION LINES SHALL BE NO LESS THAN 1.0% WITH CLEANOUTS EVERY 75 LINEAL FEET.

WATER:

- WATERLINES WILL BE 3' OFF CURB AND GUTTER UNLESS SHOWN OTHERWISE.
- LAY WATER MAINS AT LEAST 10 FEET LATERALLY FROM EXISTING OR PROPOSED SANITARY SEWERS. IF LOCAL CONDITIONS OR BARRIERS PREVENT A 10 FOOT SEPARATION, LAY THE WATER MAIN WITH AT LEAST 18" VERTICAL SEPARATION ABOVE THE TOP OF THE SANITARY SEWER PIPE EITHER IN A SEPARATE TRENCH OR IN THE SAME TRENCH ON A BENCH OF UNDISTURBED EARTH.
- WHEN A PROPOSED WATER MAIN CROSSES OVER A PROPOSED OR EXISTING SANITARY SEWER, LAY THE WATER MAIN WITH AT LEAST 18" VERTICAL SEPARATION ABOVE THE TOP OF THE SANITARY SEWER. IF LOCAL CONDITIONS PREVENT AN 18" VERTICAL SEPARATION, CONSTRUCT BOTH THE WATER MAIN AND THE SANITARY SEWER FOR A DISTANCE OF 10 FEET ON EACH SIDE TO THE POINT OF CROSSING WITH FERROUS PIPE HAVING WATER MAIN QUALITY JOINTS.
- WHEN A PROPOSED WATER MAIN CROSSES UNDER A PROPOSED OR EXISTING SANITARY SEWER, CONSTRUCT BOTH THE WATER MAIN AND THE SANITARY SEWER OF FERROUS MATERIALS WITH JOINTS THAT ARE EQUIVALENT TO WATER MAIN STANDARDS FOR A DISTANCE OF 10 FEET ON EACH SIDE OF THE POINT OF CROSSING. CENTER THE SECTION OF WATER PIPE AT THE POINT OF CROSSING.
- MAINTAIN A MINIMUM COVER OF 42" BELOW FINISHED GRADE OVER ALL PIPES UNLESS OTHERWISE DIRECTED OR SHOWN ON THE PLANS. DUE TO THE HEIGHTS OF VALVES, INCREASE THE COVER DEPTHS ADJACENT TO THE VALVES OR VARIED AT POINTS OF TIE-IN TO EXISTING LINES.
- ALL FDC(S) AND HYDRANT(S) TO BE PROVIDED WITH 5 INCH DIAMETER STORZ CONNECTIONS.
- PRIVATE FIRE SERVICE MAINS AND APPURTENANCES SHALL BE INSTALLED IN ACCORDANCE WITH NFPA 24. 2018 NCFE SECTION 507
- FDC/STANDPIPES.3313.1 WHERE REQUIRED, IN BUILDINGS REQUIRED TO HAVE STANDPIPES BY SECTION 905.3.1, NOT LESS THAN ONE STANDPIPE SHALL BE PROVIDED FOR USE DURING CONSTRUCTION. SUCH STANDPIPES SHALL BE INSTALLED PRIOR TO CONSTRUCTION EXCEEDING 40 FEET (12192 MM) IN HEIGHT ABOVE THE LOWEST LEVEL OF FIRE DEPARTMENT VEHICLE ACCESS. SUCH STANDPIPE SHALL BE PROVIDED WITH FIRE DEPARTMENT VEHICLE ACCESS. STANDPIPE SHALL BE PROVIDED WITH FIRE DEPARTMENT HOSE CONNECTIONS AT ACCESSIBLE LOCATIONS ADJACENT TO USABLE STAIRWAYS. SUCH STANDPIPES SHALL BE EXTENDED AS CONSTRUCTION PROGRESSES TO WITHIN ONE FLOOR OF THE HIGHEST POINT OF CONSTRUCTION HAVING SECURED DECKING OR FLOORING. 2018 NCFE SECTION 313

LEGEND

Water Valve	Light Pole	OLP
Curb Inlet/Catch Basin	Sewer Cleanout	OCO
Mail Box	Flored End Section	OC
Traffic Signal Box	Gas Valve	GV
Electric Transformer	Existing Iron Pipe (3/4" unless noted)	IP
Electric Junction Box	1/2" Iron Pipe Set	IPS
Gas Meter	Existing PK Nail	PK
Sanitary Sewer Manhole	PK Nail Set	PKS
Storm Sewer Manhole	Computed Point	CP
Telephone Manhole	Concrete Monument	CM
Electric Manhole	Tree Line	TL
Sign	Fence	F
Telephone Pedestal	Underground Electric	UE
Fire Hydrant	Underground Telephone	UT
Post Indicator Valve	Gas Line	GL
Water Manhole	Water Line	WL
Hot Box	Overhead Utilities	OU
Utility Pole	Storm Sewer	SS
	Sanitary Sewer	SS
	Guard Rail	GR
	Building Wall	BW

**Coulter Jewell Thames**  
111 West Main Street  
Durham, N.C. 27701  
p 919.682.0368  
f 919.688.5646  
www.cjtpa.com

Project:  
**324 ROSEMARY MIXED-USE**

324 W ROSEMARY ST.  
CHAPEL HILL, NC 27516

ORANGE COUNTY  
NORTH CAROLINA

PIN: 9788178053



PRELIMINARY  
NOT FOR CONSTRUCTION

Job Number: 1663

Drawn	JSA, ED
Checked	JSA
Date	03.17.2017
Revisions	02.19.2020 COMMENTS 04.24.2020 COMMENTS

SITE PLAN

Sheet Title:

**UTILITY PLAN**

Sheet Number  
**C400**

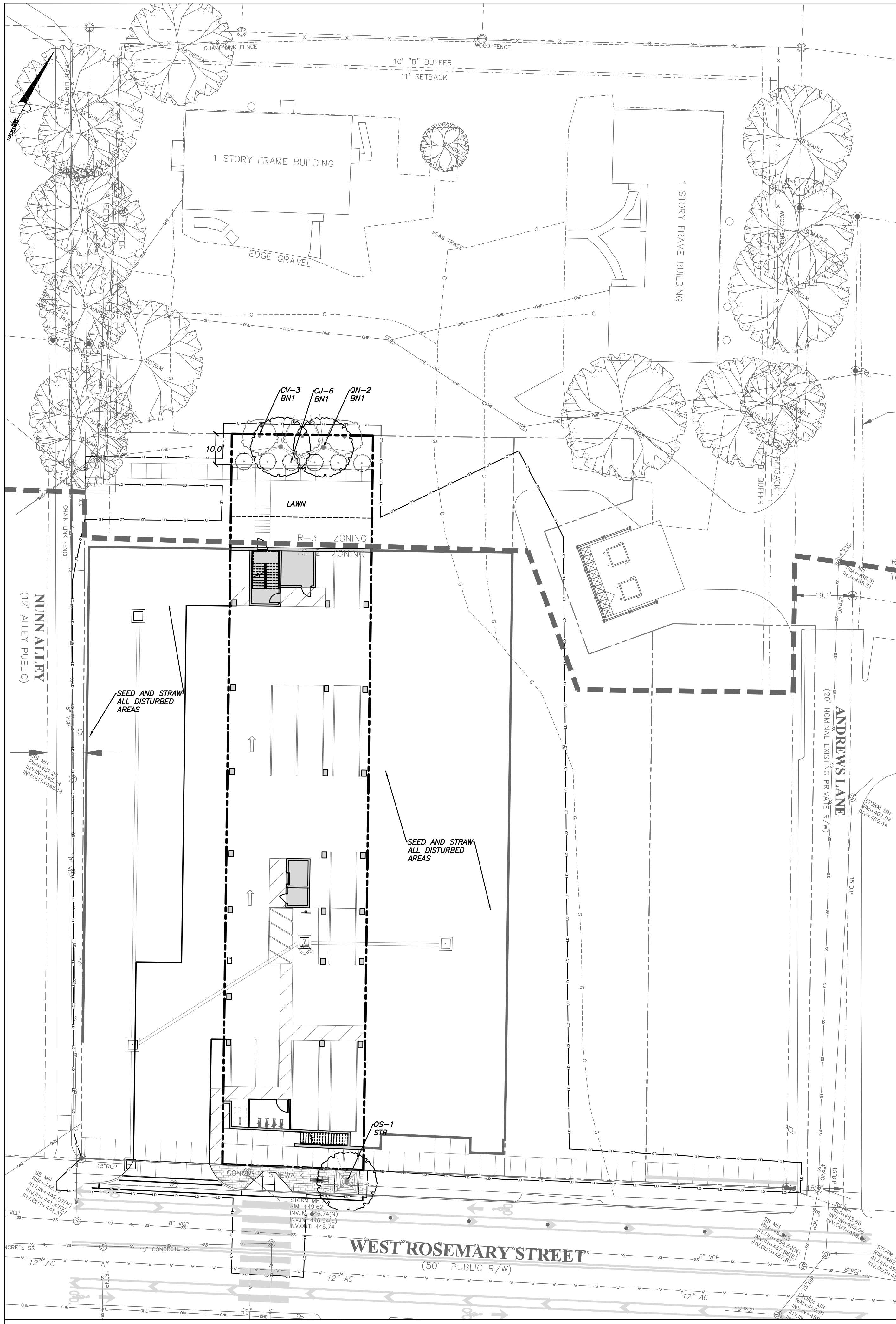

**3/C500 LANDSCAPE NOTES**  
NTS

- LANDSCAPING MUST BE IN PLACE PRIOR TO REQUEST FOR A CERTIFICATE OF OCCUPANCY OR CERTIFICATE OF COMPLIANCE.
- CONTRACTOR SHALL FIELD VERIFY ALL DIMENSIONS, DEPTHS, QUANTITIES, DISTANCES, ANGLES AND SLOPES PRIOR TO ORDERING MATERIALS OR INSTALLING PROJECT.
- IN AREAS OF GROUND COVER, MAINTAIN A 12" MINIMUM DISTANCE BETWEEN PLANTS AND HARD IMPROVEMENTS.
- BED LINES SHALL CONFORM TO CONFIGURATION SHOWN ON THE PLANS. BED LINES SHALL MEET CURBS, WALKS, BUILDINGS, ETC. AT RIGHT ANGLES UNLESS SHOWN OTHERWISE.
- CONTRACTOR SHALL VISIT THE SITE AND FAMILIARIZE THEMSELVES WITH ACTUAL CONDITIONS AND VERIFY EXISTING CONDITIONS IN THE FIELD. CONTRACTOR SHALL REPORT ALL DISCREPANCIES TO LANDSCAPE ARCHITECT.
- CONTRACTOR SHALL ACCEPT ACTUAL CONDITIONS AT SITE AND PERFORM THE WORK SPECIFIED INCLUDING FINE GRADING AND INCORPORATION OF TOP SOIL INTO PLANTING AREAS, WITHOUT ADDITIONAL COMPENSATION FOR POSSIBLE VARIATION FROM GRADES AND CONDITIONS SHOWN, WHETHER SURFACE OR SUBSURFACE, EXCEPT AS PROVIDED FOR IN CONTRACT DOCUMENTS.
- IN LAWN AREAS, 2" TOPSOIL SHALL BE TILLED INTO THE TOP 5" OF GROUND PRIOR TO SEEDING.
- CONTRACTOR WILL OBTAIN WRITTEN APPROVAL FROM LANDSCAPE ARCHITECT FOR ANY PLANT SUBSTITUTIONS OF SPECIES, SIZE, OR TYPE OF CONTAINER.
- CONTRACTOR SHALL LOCATE ALL UNDERGROUND UTILITIES PRIOR TO CONSTRUCTION AND SHALL BE RESPONSIBLE FOR THE PROTECTION OF THESE UTILITIES DURING INSTALLATION, AND SHALL PROMPTLY REPAIR AND RESTORE SERVICES AT NO ADDITIONAL COST TO THE OWNER IF DAMAGE OCCURS DURING INSTALLATION. CONTRACTOR SHALL BECOME THOROUGHLY FAMILIAR WITH THE FULL SET OF CONSTRUCTION DRAWINGS AND SPECIFICATIONS FOR COORDINATION WITH UTILITIES, ARCHITECTURAL FEATURES, ETC.
- CONTRACTOR WILL LEAVE DISTURBED AREAS LEVEL AND RAKED SMOOTH, REMOVING ALL ROCKS AND DEBRIS.
- MULCH IS TO BE A 3" LAYER OF TRIPLE SHREDDED HARDWOOD MULCH. MULCH IS TO BE KEPT AWAY FROM TREE TRUNKS.
- ANY DAMAGE TO EXISTING CONDITIONS OUTSIDE THE CONTRACT LIMITS, INCLUDING CURBS, SIDEWALKS, TURF AREAS AND PAVING, SHALL BE RESTORED TO ORIGINAL CONDITION BY THE CONTRACTOR WITHOUT EXTRA COST TO THE OWNER.
- IN CASE OF DISCREPANCY BETWEEN THE QUANTITY OF PLANTS ON THE PLANS COMPARED TO THE PLANT LIST, THE CONTRACTOR SHALL SUPPLY QUANTITIES AS SHOWN ON THE PLANS.
- ALL UNPAVED SURFACES ARE TO BE COVERED IN PLANTS, MULCH, OR GRASS.

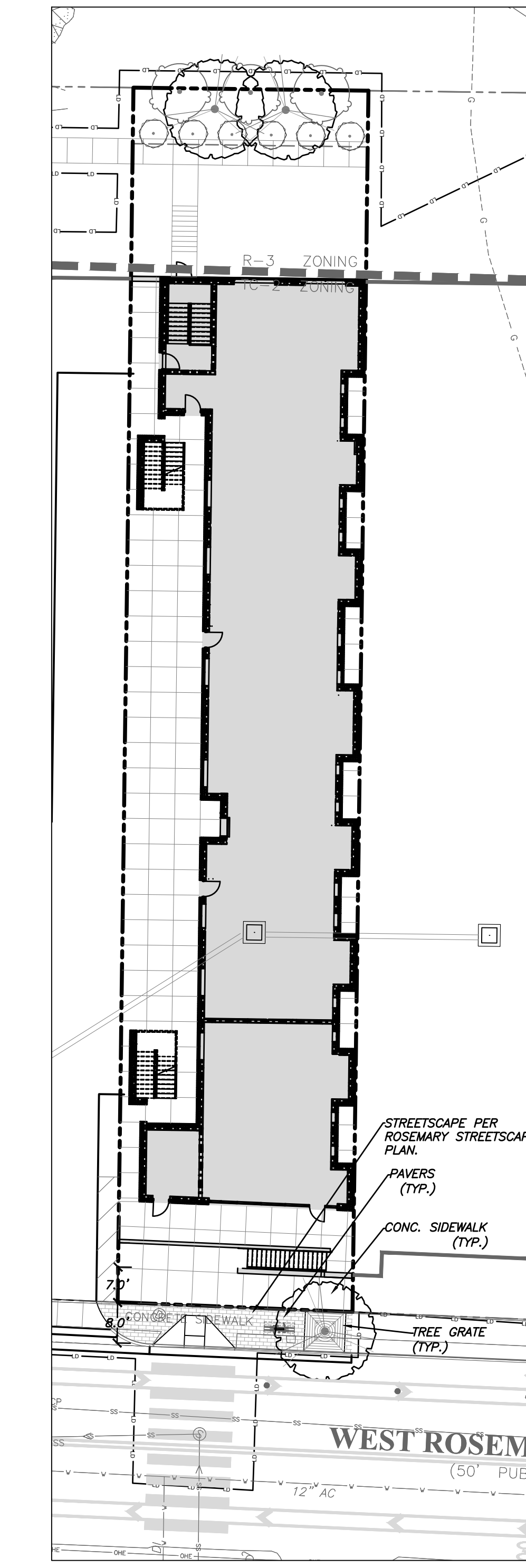

**2/C500 LANDSCAPE / STREETScape PLAN**  
SCALE: 1"=20'

**3/C500 LANDSCAPE CALCULATIONS**  
NTS

USE CLASSIFICATION: DWELLING UNITS, 7 OR MORE (USE GROUP A)  
ADJACENT USE CLASSIFICATION: DWELLING UNITS, 7 OR MORE (USE GROUP A)

NORTHERN BUFFER = TYPE B INTERNAL BUFFER (10' MIN.)  
PLANTINGS PER 100 LF  
4 LARGE TREES  
7 SMALL TREES  
12 SHRUBS

PLANTINGS PROVIDED = 46' PL  
2 LARGE TREES  
3 SMALL TREES  
6 SHRUBS

**4/C500 LANDSCAPE PLANTING SCHEDULE**  
NTS

QTY	%	EVGN	KEY	BOTANICAL NAME	COMMON NAME	SIZE	SPACING	REMARKS
3		N	QN	<i>Quercus nuttallii</i>	Nuttall Oak	2" cal.	8'-10' hgt.	Single leader
1		N	QS	<i>Quercus shumardii</i>	Shumard Oak	3" cal.		Single leader, Limb to 7'
3		N	CV	<i>Chionanthus virginicus</i>	Fringetree	1.5" cal.	5'-6' hgt.	Single trunk
6		Y	CJ	<i>Camellia japonica</i> 'Jacks'	Spring Camellia	3 gal.	18" hgt.	Full, Matching

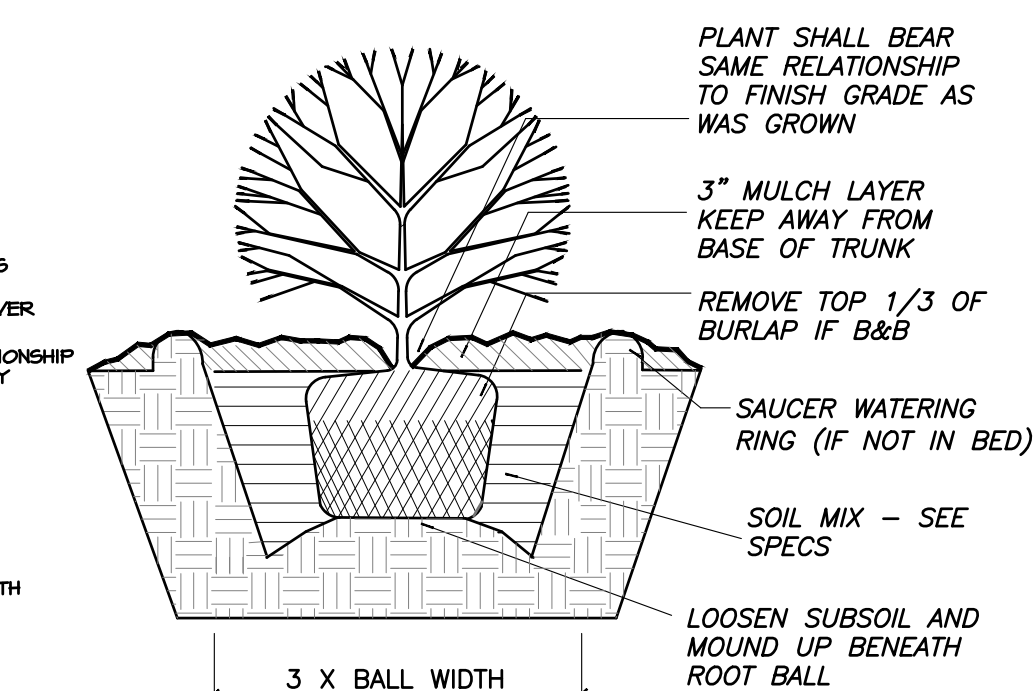
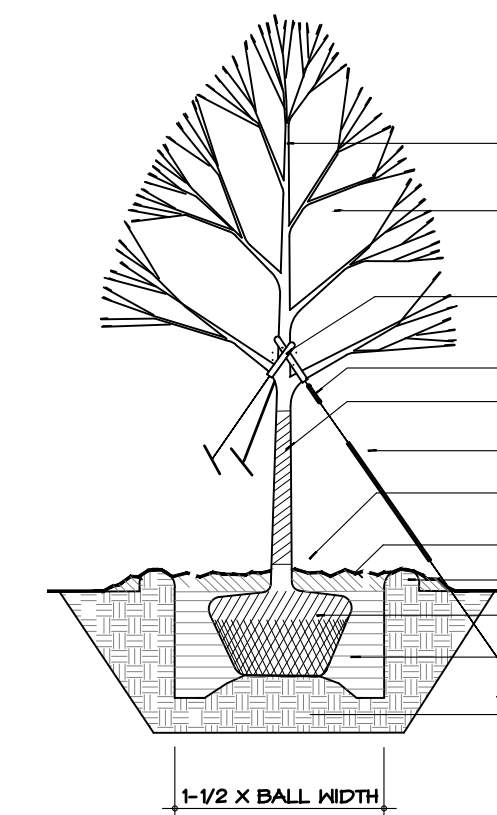

**5/C500 TREE PLANTING DETAIL**  
NTS

**6/C500 SHRUB PLANTING DETAIL**  
NTS

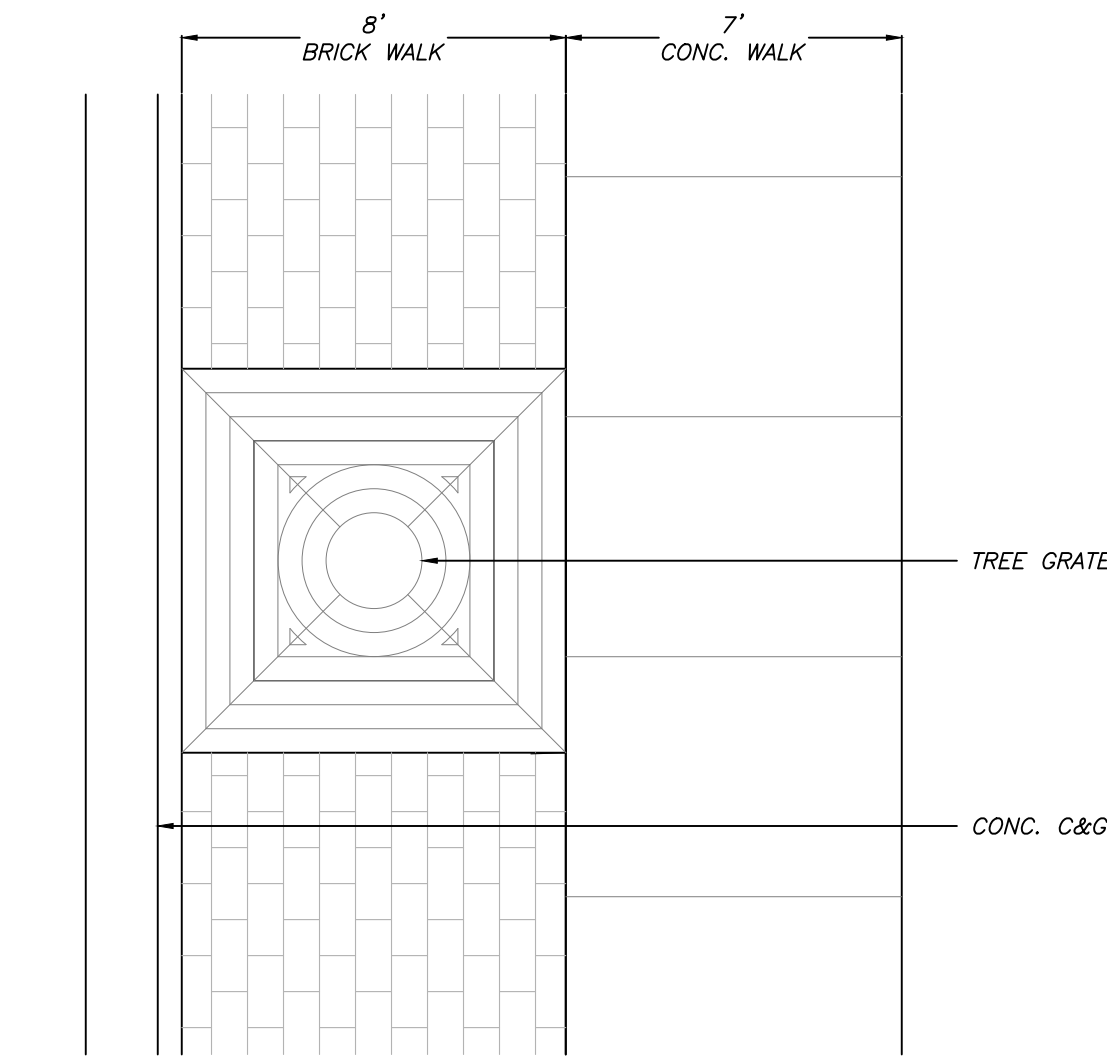

**7/C500 SIDEWALK TYPE 'A' - URBAN STYLE**  
NTS

**LEGEND**

Water Valve	⊗	Light Pole	○LP
Curb Inlet/Catch Basin	□	Sewer Cleanout	○CO
Mail Box	MB	Flared End Section	○
Traffic Signal Box	TSB	Gas Valve	⊗GV
Electric Transformer	ET	Existing Iron Pipe (3/4" unless noted)	○IPS
Electric Junction Box	EJB	1/2" Iron Pipe Set	○IPS
Gas Meter	GM	Existing PK Nail	●PK
Sanitary Sewer Manhole	SSM	PK Nail Set	●PKS
Storm Sewer Manhole	SSSM	Computed Point	△
Telephone Manhole	TMH	Concrete Monument	⊠
Electric Manhole	EMH	Tree Line	—
Sign	S	Fence	—
Telephone Pedestal	TEL	Underground Electric	—
Fire Hydrant	●	Underground Telephone	—
Post Indicator Valve	●PIV	Gas Line	—
Water Manhole	WMH	Water Line	—
Hot Box	HB	Overhead Utilities	—
Utility Pole	UP	Storm Sewer	—
		Sanitary Sewer	—
		Guard Rail	—
		Building Wall	—

**Coulter Jewell Thames**  
111 West Main Street  
Durham, N.C. 27701  
p 919.682.0368  
f 919.688.5646  
www.cjtpa.com

Project:  
**324 ROSEMARY MIXED-USE**

324 W ROSEMARY ST.  
CHAPEL HILL, NC 27516

ORANGE COUNTY  
NORTH CAROLINA

PIN: 9788178053



PRELIMINARY  
NOT FOR CONSTRUCTION

Job Number: 1663

Drawn	JSA, ED
Checked	JSA
Date	08.17.2017
Revisions	02.19.2020 COMMENTS
	04.24.2020 COMMENTS

SITE PLAN

Sheet Title:

**LANDSCAPE / STREETScape PLAN**

Sheet Number  
**C500**

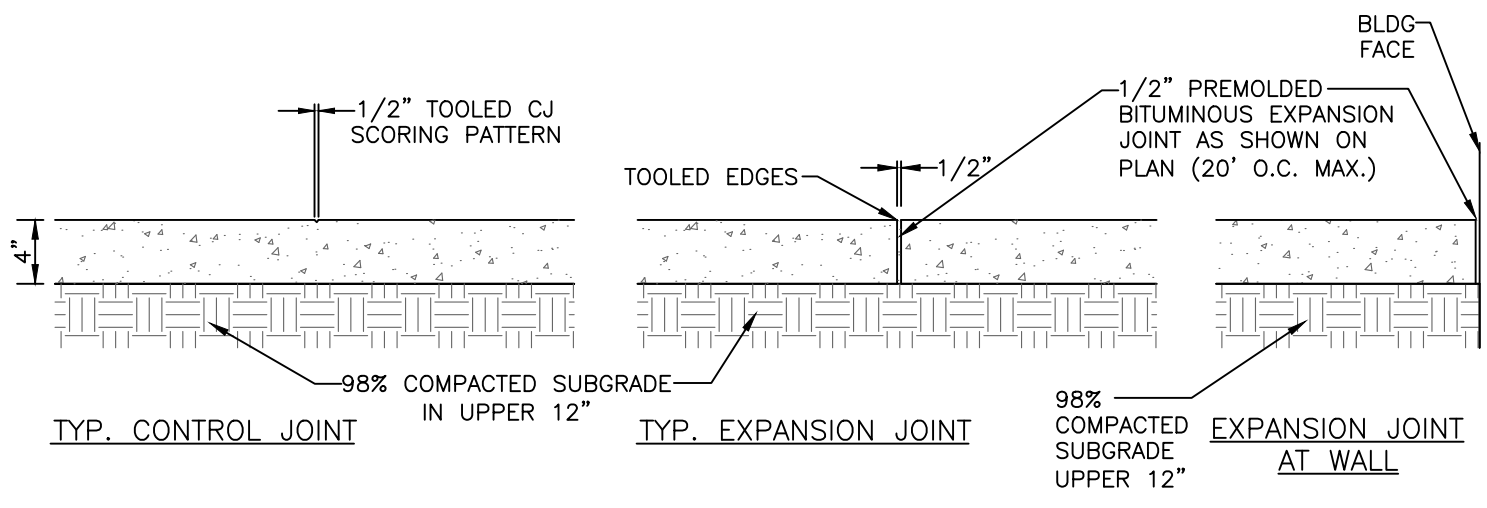
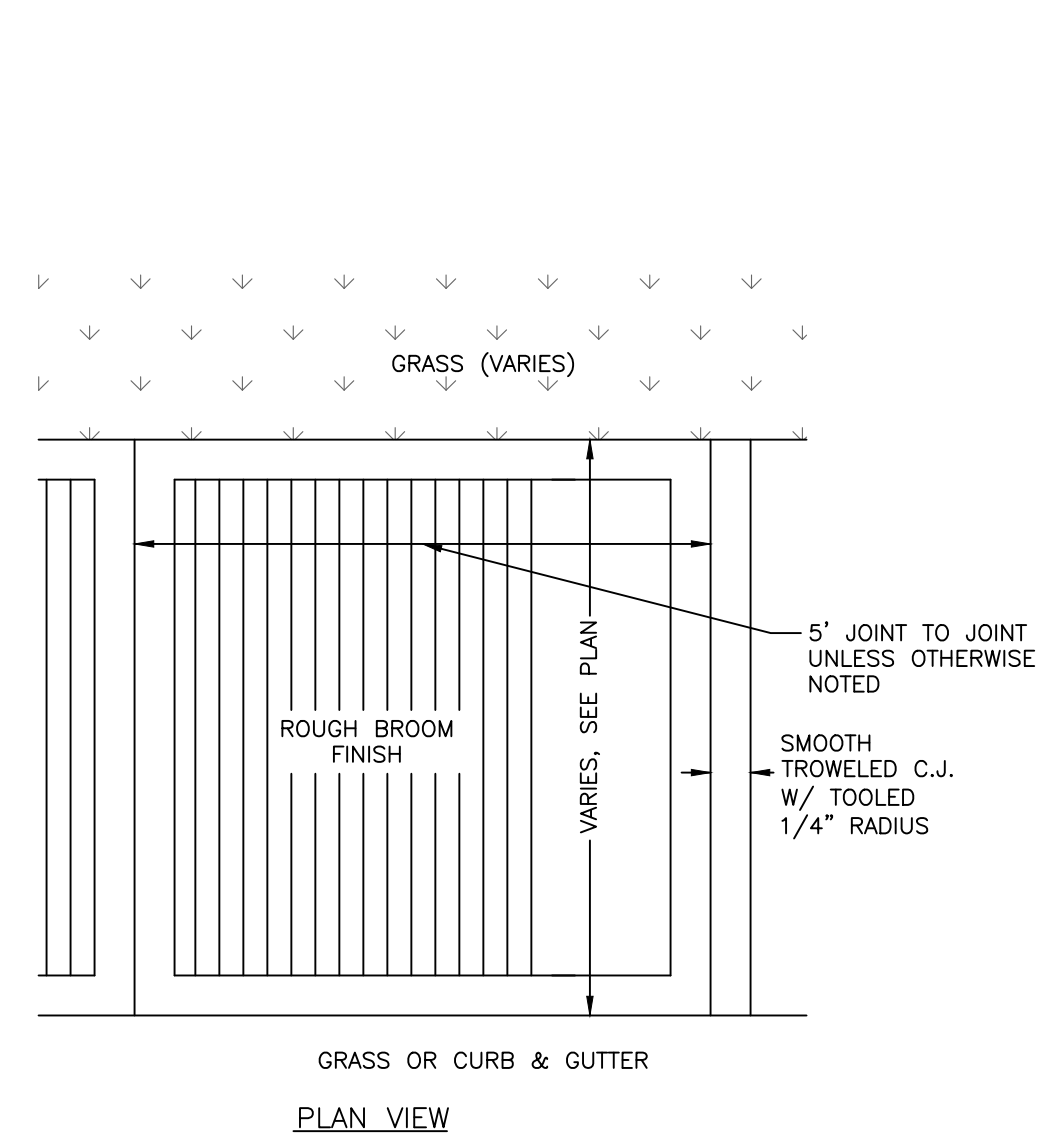

- NOTES:
- 1) 4" THICK CONC., 3000 PSI MIN.
  - 2) ALL SIDEWALK ARE TO HAVE MAXIMUM 1.8% CROSS SLOPE
  - 3) USE 1/2" BITUMINOUS EXPANSION JOINT A MAX. OF 20' O.C. AND WHENEVER CONCRETE WALK MEETS FIXED OBJECTS (I.E. CURBS, BLDG. ETC.), EXPANSION JOINTS THAT ABUT BUILDINGS WALL SHALL BE SEALED WITH A FOAM BACKER ROD AND ELASTOMERIC SEALANT.
  - 4) ALL SIDEWALKS SHALL BE CONSTRUCTED WITH TOOLED 1/4" EDGE RADIUS.
- ALL CONSTRUCTION JOINTS AND EXPANSION JOINTS IN NCDOT RIGHT-OF-WAY SHALL BE SEALED PER NCDOT STANDARDS AND SPECIFICATION.

1 CONCRETE SIDEWALK  
C600 no scale

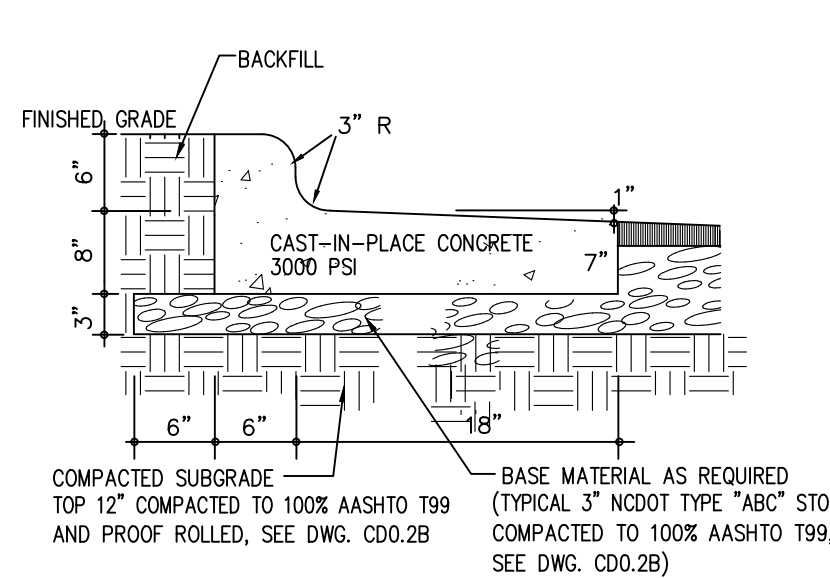

SPILL CURB AS REQ.

2 CURB AND GUTTER  
C600 no scale

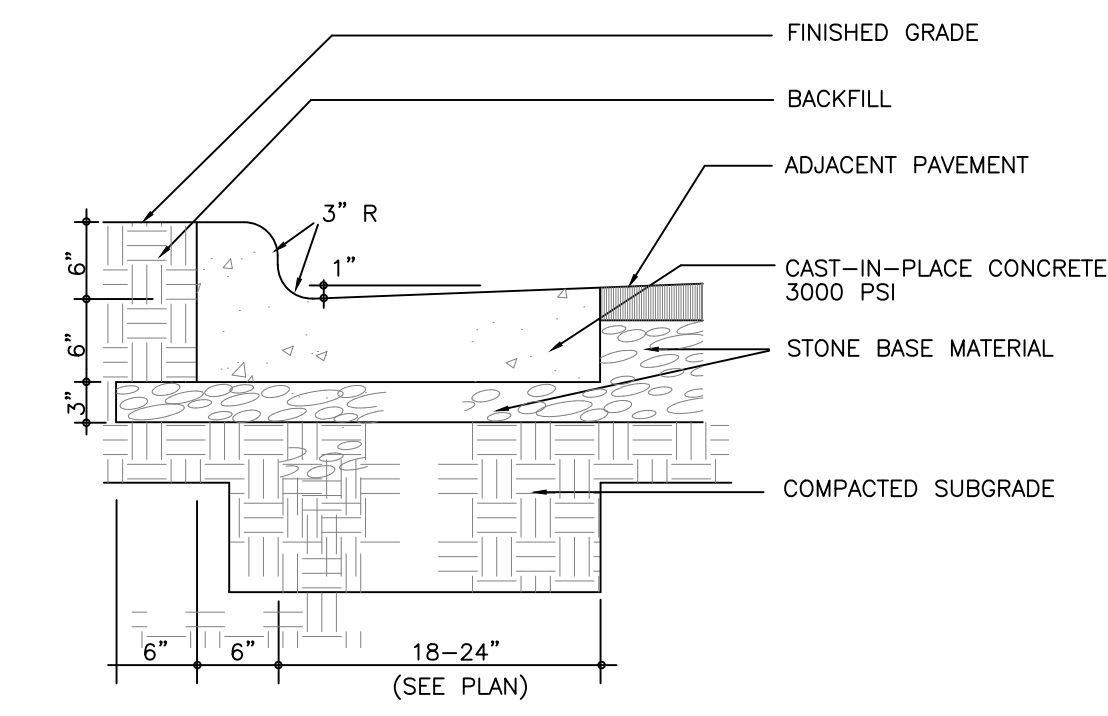

- CONTRACTION JOINTS SHALL BE SPACED AT 10 FOOT INTERVALS. EXCEPT THAT A 15 FOOT SPACING MAY BE USED WHEN A MACHINE IS USED OR WHEN SATISFACTORY SUPPORT FOR THE FACE FORM CAN BE OBTAINED WITHOUT THE USE OF TEMPLATES AT 10 FOOT INTERVALS. JOINT SPACING MAY BE ALTERED BY THE ENGINEER TO PREVENT UNCONTROLLED CRACKING.
- CONTRACTION JOINTS MAY BE INSTALLED BY THE USE OF TEMPLATES OR FORMED BY OTHER APPROVED METHODS. WHERE SUCH JOINTS ARE NOT FORMED BY TEMPLATES, A MINIMUM DEPTH OF 1 1/2" SHALL BE MAINTAINED.
- CONCRETE FOR CURBING SHALL HAVE A MINIMUM COMPRESSION STRENGTH OF 3000 PSI AT 28 DAYS.
- ALL CONTRACTION JOINTS SHALL BE FILLED WITH JOINT FILLER.
- JOINTS SHALL MATCH LOCATIONS WITH JOINT IN ABUTTING SIDEWALK.
- EXPANSION JOINTS SHALL BE SPACED AT 90 FOOT INTERVALS AND ADJACENT TO ALL RIGID OBJECTS.

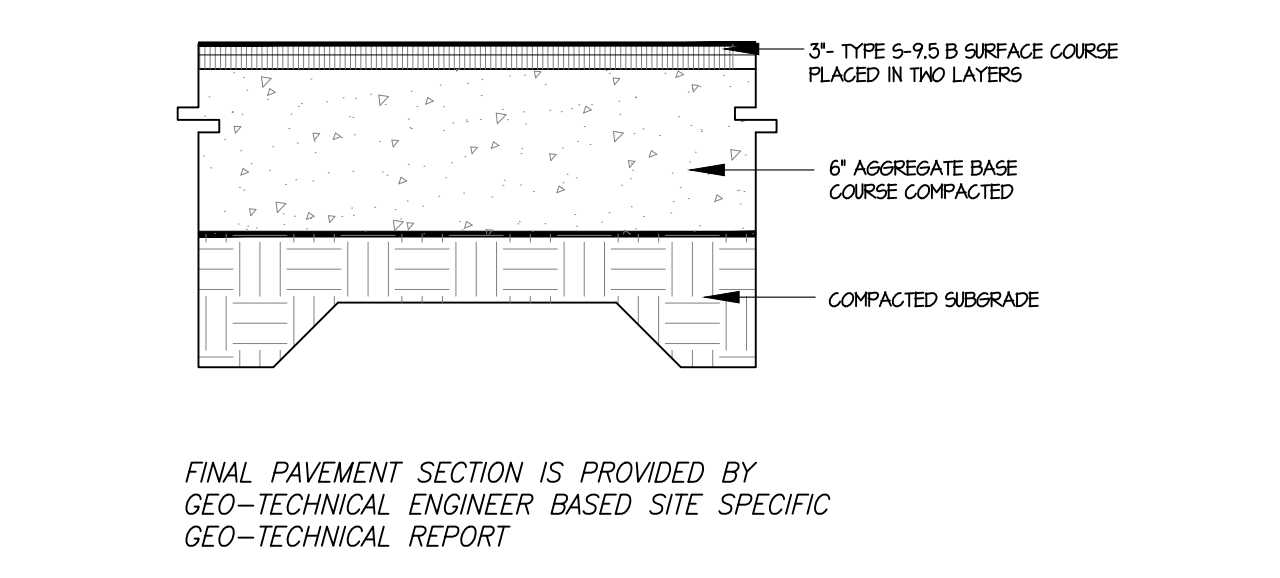

3 LIGHT DUTY ASPHALT PAVING  
C600 no scale

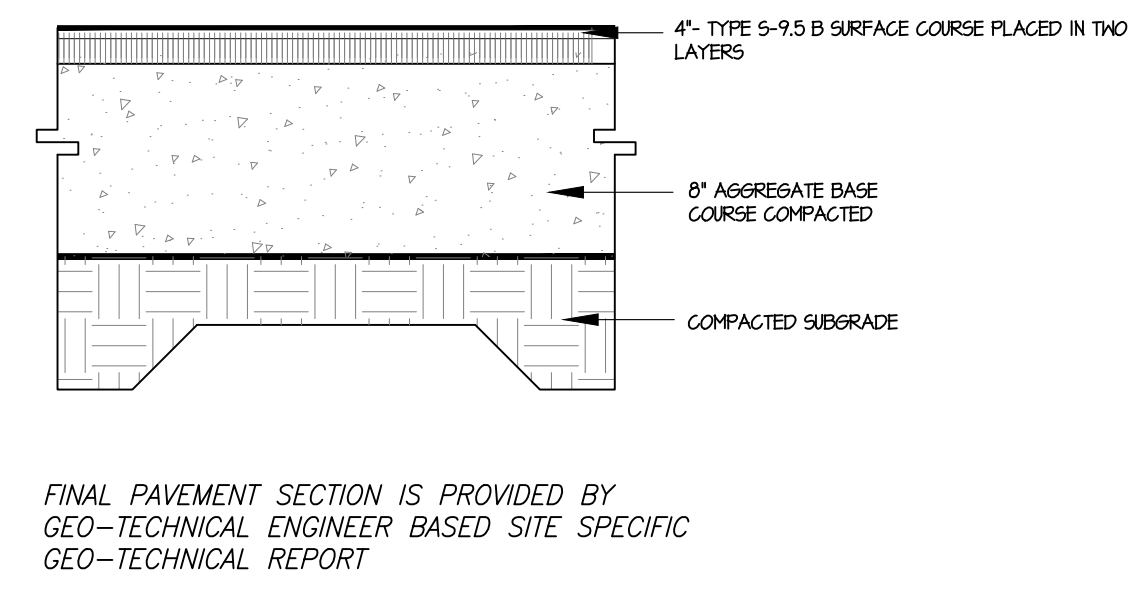

4 HEAVY DUTY ASPHALT PAVING  
C600 no scale

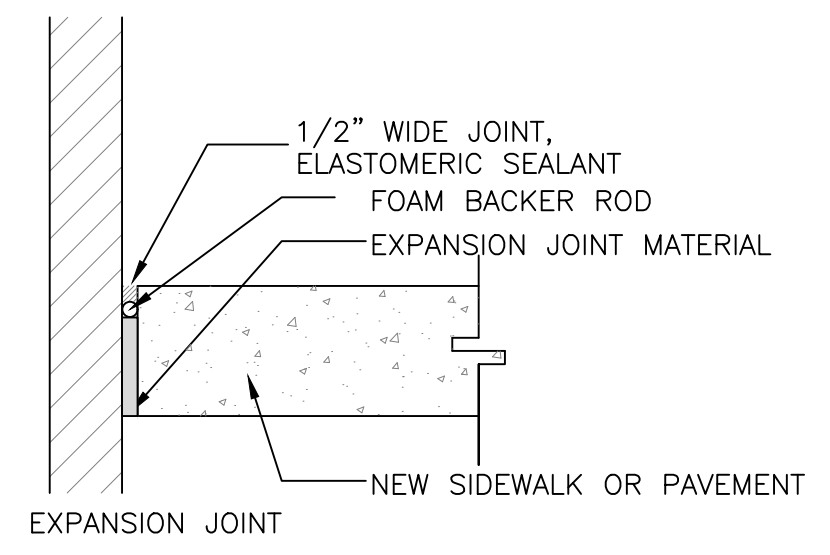

5 PAVING ADJACENT TO BUILDING  
C600 no scale

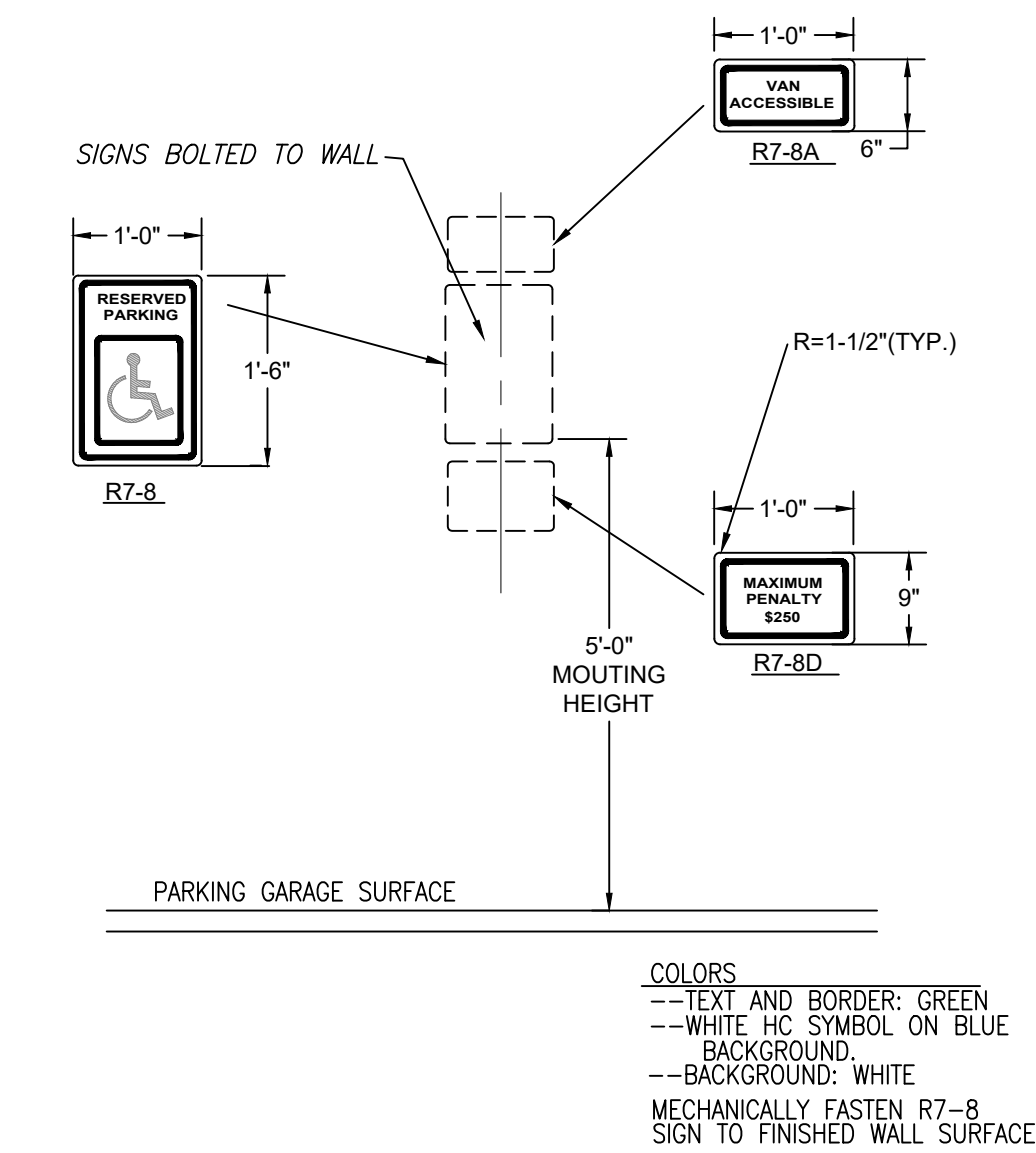

6 ADA SIGNAGE  
C600 no scale

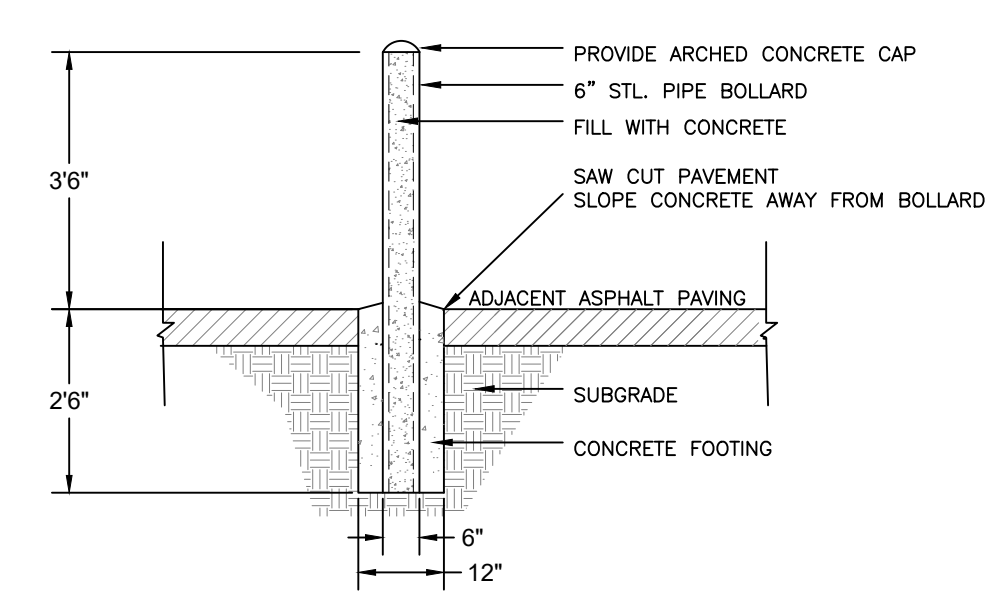

7 BOLLARD  
C600 no scale

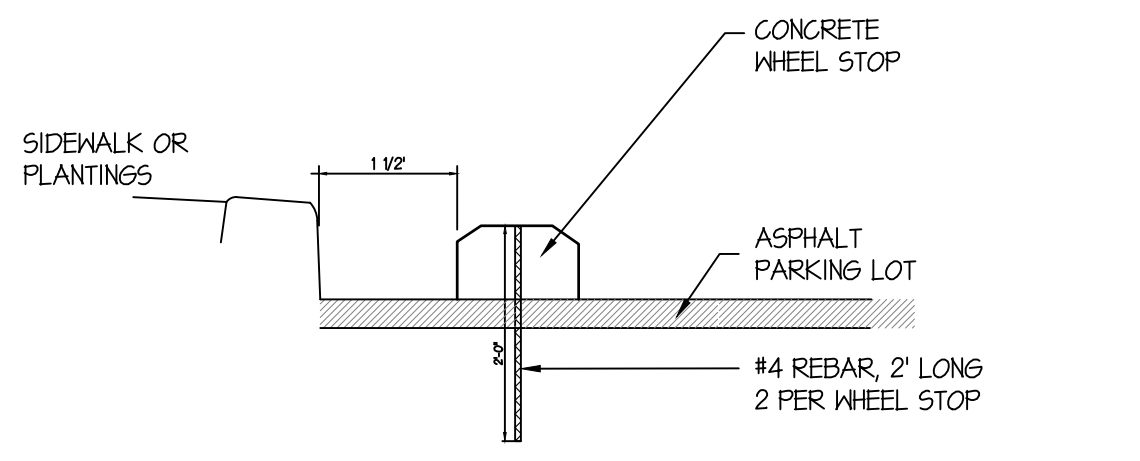

8 WHEELSTOP  
C600 no scale

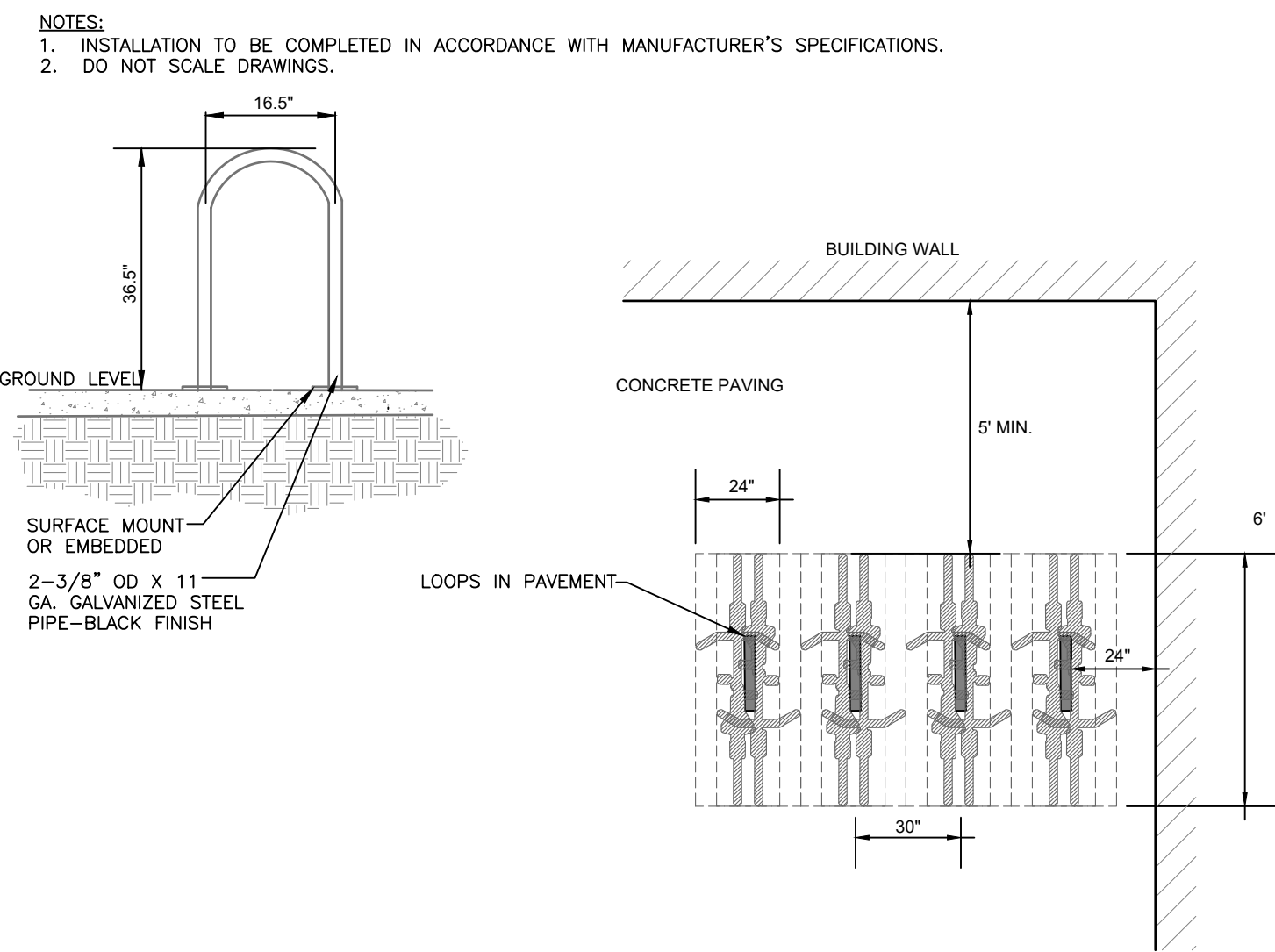

9 BIKE RACK  
C600 no scale

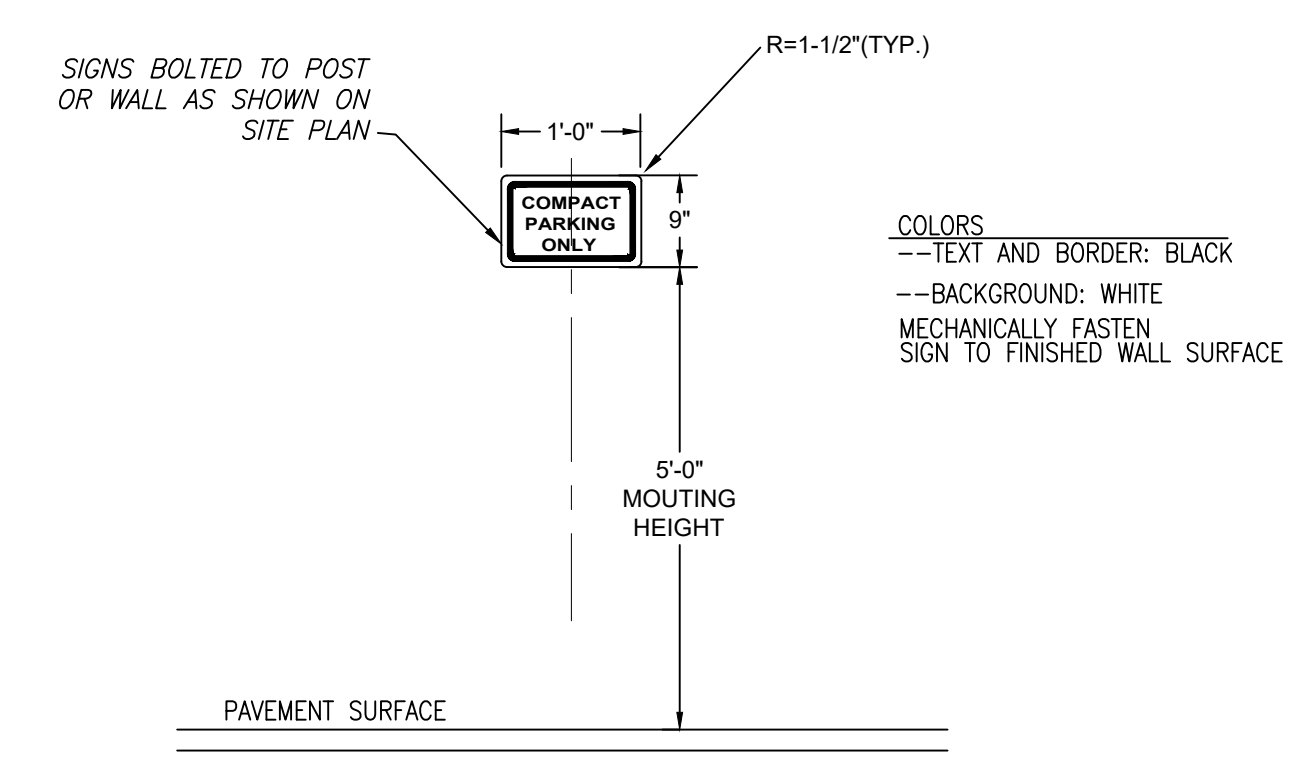

10 COMPACT PARKING SPACE SIGNAGE  
C600 no scale

Coulter Jewell Thames P.A.

111 West Main Street  
Durham, N.C. 27701  
p 919.682.0368  
f 919.688.5646  
www.cjtpa.com

Project:  
**324 ROSEMARY MIXED-USE**

324 W ROSEMARY ST.  
CHAPEL HILL, NC 27516

ORANGE COUNTY  
NORTH CAROLINA

PIN: 9788178053

04.24.2020

PRELIMINARY NOT FOR CONSTRUCTION

Job Number: 1663

Drawn	JSA, ED
Checked	JSA
Date	03.17.2017
Revisions	02.19.2020 COMMENTS 04.24.2020 COMMENTS

SITE PLAN

Sheet Title:  
**SITE DETAILS**

Sheet Number  
**C600**

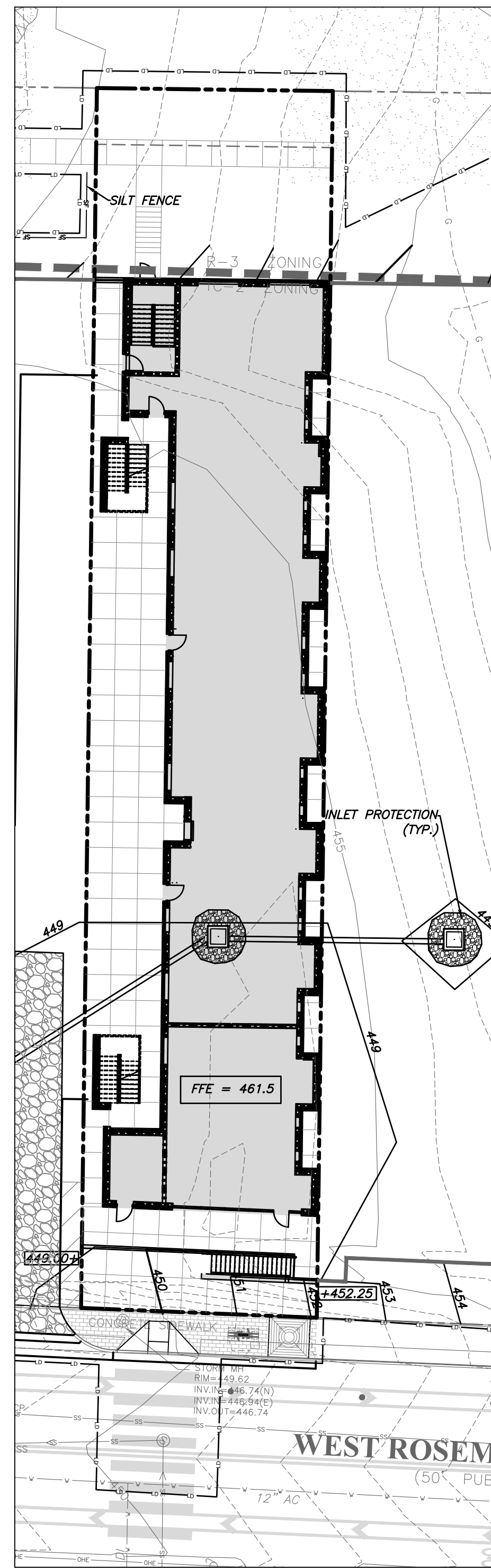
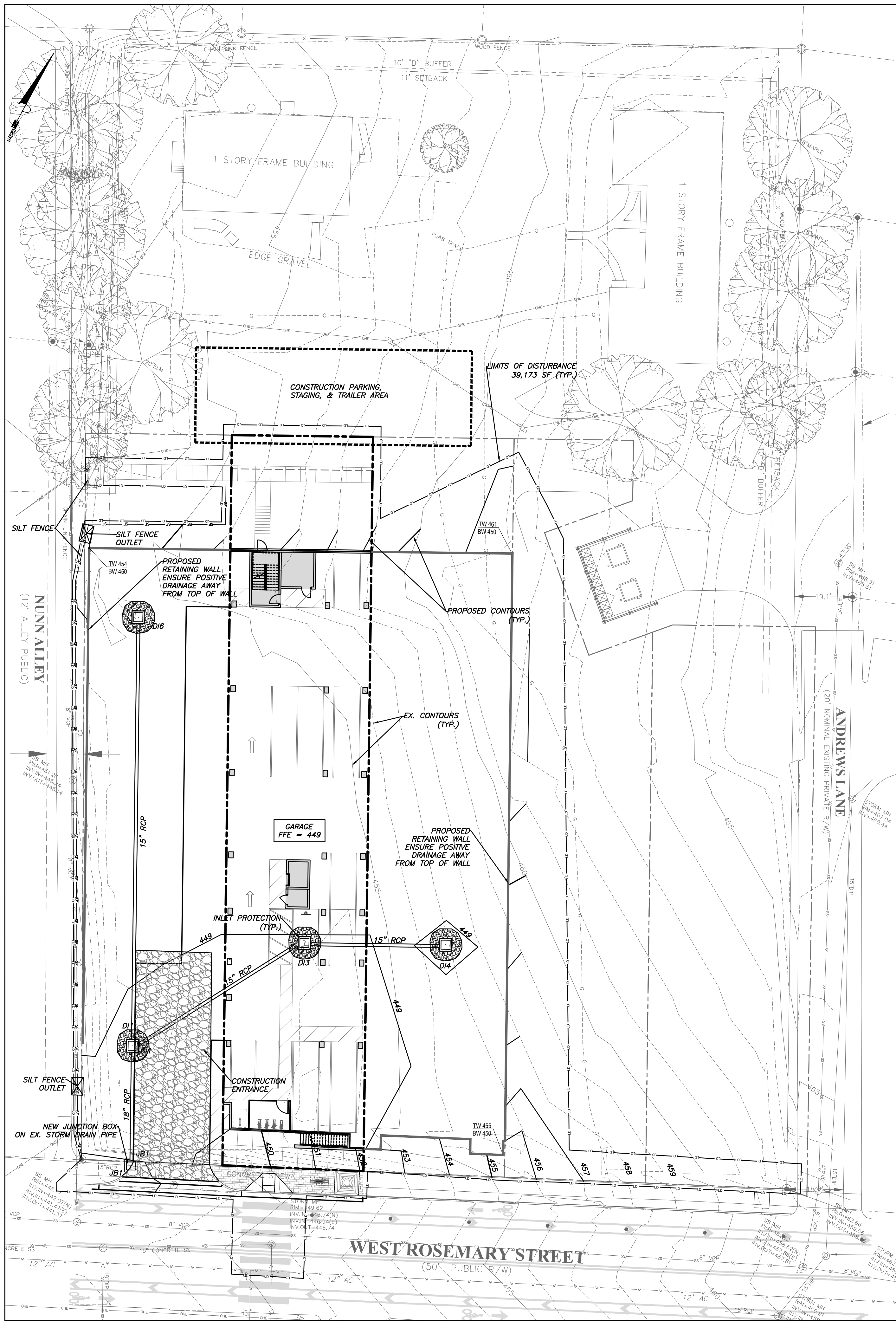

### CONSTRUCTION SEQUENCE

#### Pre Construction

1. Verify that all approvals and permits necessary to begin and complete the project are in hand. Approval and permits must be obtained prior to disturbance so that work will not be interrupted or delayed due to the lack of approved plans.
2. Schedule and hold a preconstruction conference before starting demolition, clearing or grading with the owner, contractor responsible for grading and erosion control, person responsible for supervising implementation of the erosion control plan, and the Orange County Erosion Control Inspector.
3. Install a box on the site to hold a copy of the approved erosion control plan and to provide a place for the inspector(s) to leave inspection reports, compliance notices, etc. Place the box in a convenient location, such as at the entrance to the site or next to the construction trailer. Erosion control personnel will leave correspondence in the box and raise the red flag if personnel responsible for erosion control cannot be located on the site. Site personnel should check the box daily.
4. Install gravel construction entrance.
5. Install silt fence and tree protection. Install inlet protection around existing inlets. Clear and demo areas shown inside of the limits of disturbance as necessary to begin construction. Limit disturbance to areas necessary for construction activities at that time. Stabilize disturbed areas as soon as possible.
6. Demo existing utilities as shown and construct new storm drainage. Install inlet protection around new inlets immediately after construction. Seal all junction boxes from stormwater intake from surface. Seal any inlets to stormwater structures not protected by inlet protection.
7. Minimize the amount of area disturbed at any one time.
8. During construction, some temporary measures will be removed to allow construction of permanent facilities.
9. If it is determined during the course of construction that significant sediment is leaving the site despite proper implementation and maintenance of the approved erosion control plan, the person responsible for the land disturbing activity is obligated to take additional protective action.

10. Inspect and maintain the erosion control devices so they continue to function properly. Refer to the instructions in the erosion control plan for specific instructions for each device. The person responsible for erosion control is also responsible for taking the initiative in inspecting and maintaining these devices. Do not wait for erosion control personnel to point out the need for repairs and maintenance. Keep mud and debris off the public street at all times. If mud or debris is tracked from the site, use a shovel and broom to remove it immediately. IF MUD AND DEBRIS ARE NOT KEPT OFF THE STREET, ENFORCEMENT ACTION (REVOKING THE GRADING PERMIT AND/OR A STOP WORK ORDER) MAY BE TAKEN!!
11. In addition to the inspections by the Contractor the Owner, the Financially Responsible Party, or their Agent must conduct inspections in accordance with the NPDES General Permit and NCDEQ's Self-Inspection Program for Erosion and Sediment Control.
12. Permanently stabilize all disturbed areas. Refer to seeding schedule for types of stabilization to be used.

13. When construction is completed, remove all temporary erosion control devices after the drainage area above has been sufficiently stabilized to restrain erosion. Remove and properly dispose of accumulated sediment and the debris from the devices, and stabilize the location.
- Arrange a final inspection with the erosion control inspector to confirm that all requirements of the approved erosion control plan have been completed.

### EROSION CONTROL LEGEND

- INLET PROTECTION
- DIVERSION DITCH
- CONSTRUCTION ENTRANCE
- SILT FENCE
- TREE PROTECTION FENCE
- SILT FENCE OUTLET
- TEMPORARY SEEDING
- PERMANENT SEEDING

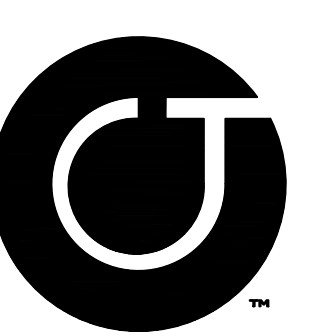

**Coulter  
Jewell  
Thames**

111 West Main Street  
Durham, N.C. 27701  
p 919.682.0368  
f 919.688.5646  
www.cjtpa.com

Project:

**324 ROSEMARY  
MIXED-USE**

324 W ROSEMARY ST.  
CHAPEL HILL, NC 27516

ORANGE COUNTY  
NORTH CAROLINA

PIN: 9788178053



PRELIMINARY  
NOT FOR CONSTRUCTION

Job Number: 1663

Drawn	JSA, ED, TRM
Checked	JSA
Date	04.20.2020
Revisions	

EROSION CONTROL PLAN

Sheet Title:

**EROSION  
CONTROL PLAN**

Sheet Number

**C700**

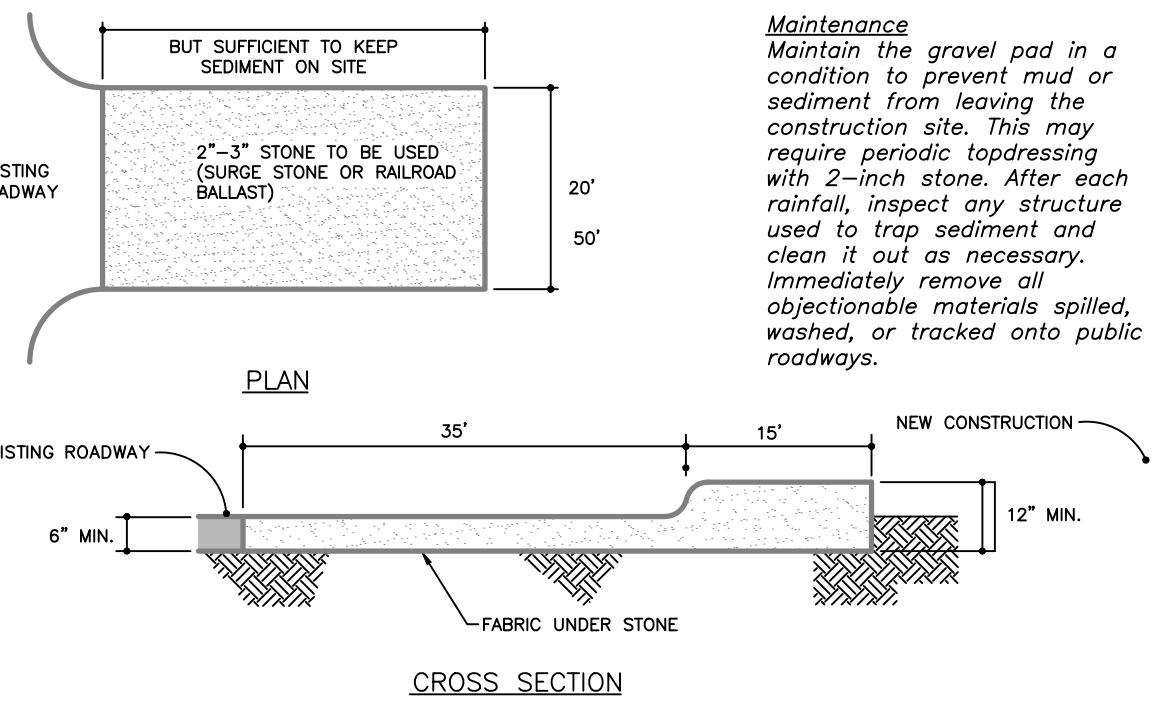

- NOTES:**
1. PUT SILT FENCE OR TREE PROTECTION FENCE UP TO ENSURE CONSTRUCTION ENTRANCE IS USED.
  2. IF CONSTRUCTION ON THE SITES ARE SUCH THAT THE MUD IS NOT REMOVED BY THE VEHICLE TRAVELING OVER THE STONE, THEN THE TIRES OF THE VEHICLES MUST BE WASHED BEFORE ENTERING THE PUBLIC ROAD.
  3. IF A PROJECT CONTINUES TO PULL MUD AND DEBRIS ON TO THE PUBLIC ROAD, THE GOVERNING AUTHORITY WILL CLEAN THE AREA AND INVOICE THE FINANCIALLY RESPONSIBLE PERSON AS INDICATED ON THE FINANCIAL RESPONSIBILITY FORM.

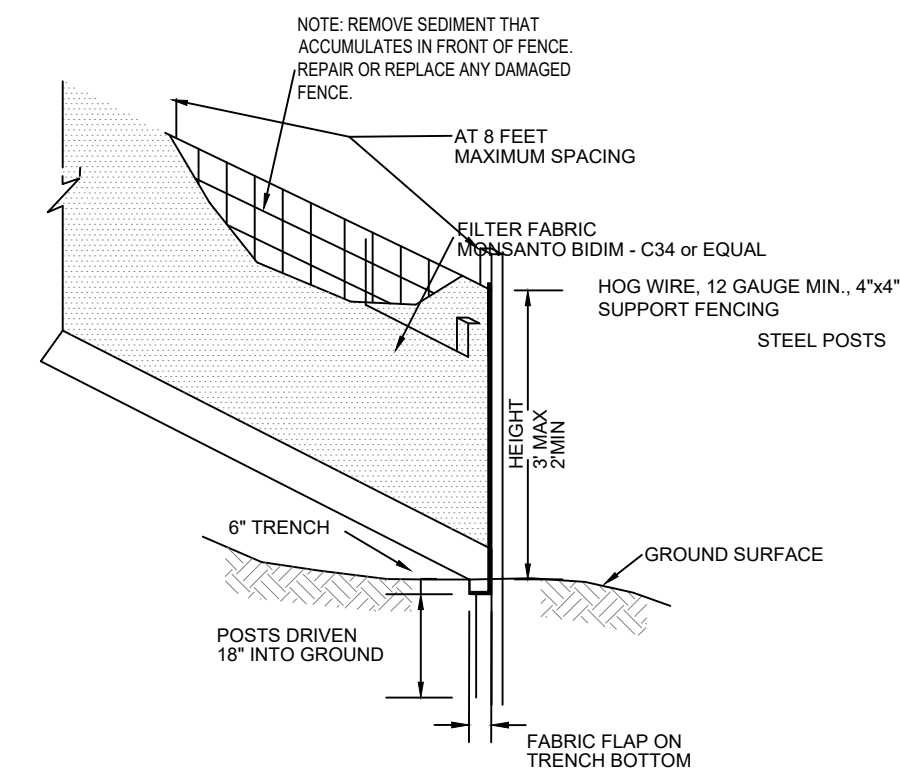

- MAINTENANCE**
1. INSPECT SEDIMENT FENCES AT LEAST ONCE A WEEK AND AFTER EACH RAINFALL. MAKE ANY REQUIRED REPAIRS IMMEDIATELY.
  2. SHOULD THE FABRIC OF A SEDIMENT FENCE COLLAPSE, TEAR, DECOMPOSE OR BECOME INEFFECTIVE, REPLACE IT PROMPTLY.
  3. REMOVE SEDIMENT DEPOSITS AS NECESSARY TO PROVIDE ADEQUATE STORAGE VOLUME FOR THE NEXT RAIN AND TO REDUCE PRESSURE ON THE FENCE. TAKE CARE TO AVOID UNDERMINING THE FENCE DURING CLEANOUT.
  4. REMOVE ALL FENCING MATERIALS AND UNSTABLE SEDIMENT DEPOSITS AND BRING THE AREA TO GRADE AND STABILIZE IT AFTER THE CONTRIBUTING DRAINAGE AREA HAS BEEN PROPERLY STABILIZED.

**3/C701 SEEDING SCHEDULE**  
N.T.S.

Site Area Description	Stabilization Time Frame	Stabilization Time Frame Exceptions
Perimeter dikes, swales, ditches, and slopes	7 days	None
High Quality Water (H2O) Zones	7 days	None
Slopes steeper than 3:1	7 days	None
Slopes 3:1 or flatter	7 days	None
All other areas with slopes flatter than 4:1	7 days	None

**Ground Stabilization\***

Site Area Description	Stabilization Time Frame	Stabilization Time Frame Exceptions
Perimeter dikes, swales, ditches, and slopes	7 days	None
High Quality Water (H2O) Zones	7 days	None
Slopes steeper than 3:1	7 days	None
Slopes 3:1 or flatter	7 days	None
All other areas with slopes flatter than 4:1	7 days	None

\*Extensions of time may be approved by the permitting authority based on weather or other site-specific conditions that make compliance impracticable" (Section 11.8(2)(b))

- "EXPOSED" AREAS INCLUDE, BUT ARE NOT LIMITED TO:**
- AREAS CLEARED FOR ROADWAY CONSTRUCTION,
  - AREAS CLEARED ON RESIDENTIAL BUILDING LOTS,
  - DRAINAGE EASEMENTS AND OPEN DRAINAGE CHANNELS,
  - SEDIMENT AND EROSION CONTROL MEASURES (SEDIMENT TRAPS, DIVERSION DITCHES, ETC.) AND THE AREAS ADJACENT TO SUCH MEASURES.

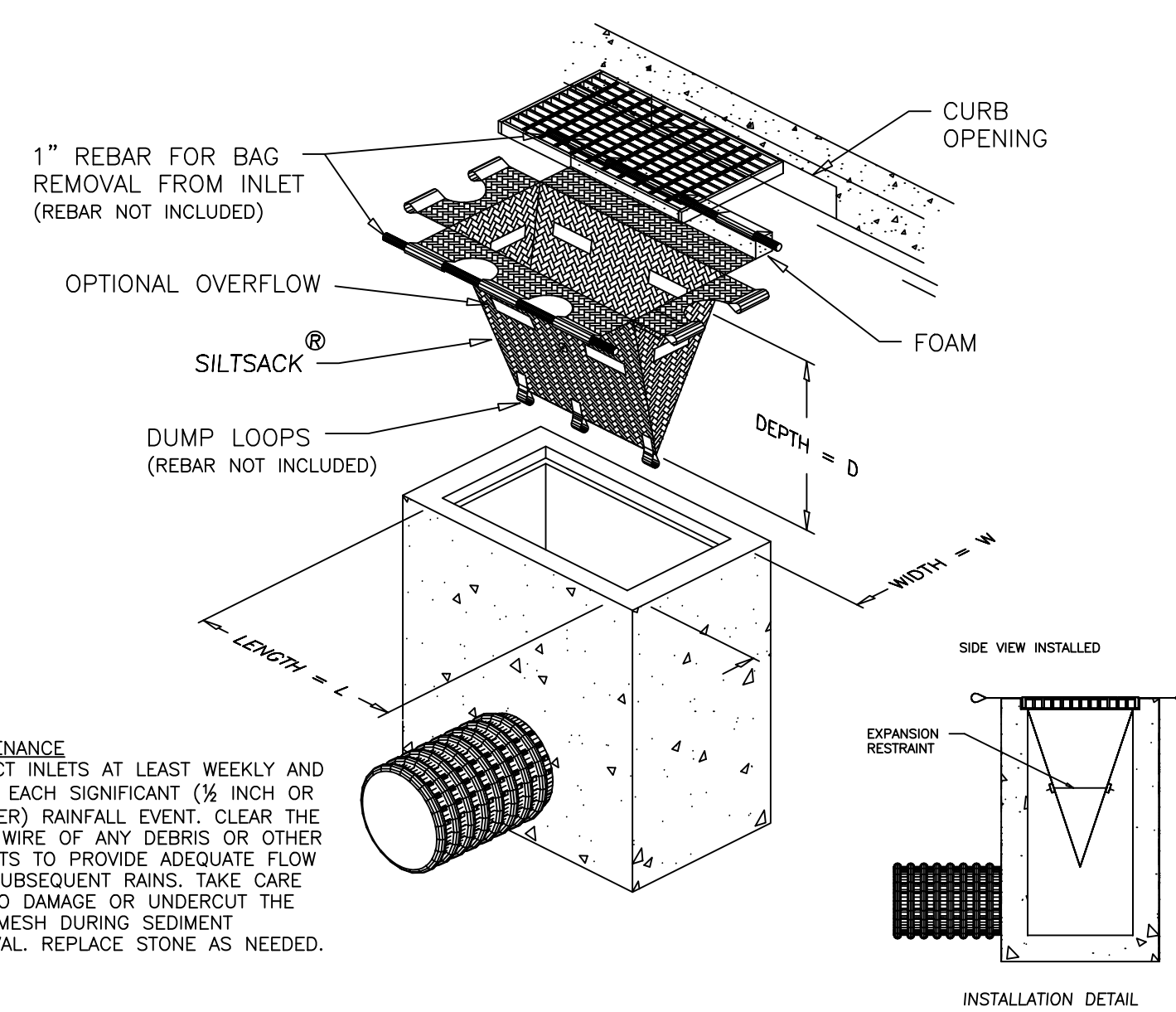

- MAINTENANCE**
- INSPECT INLETS AT LEAST WEEKLY AND AFTER EACH SIGNIFICANT (1/2 INCH OR GREATER) RAINFALL EVENT. CLEAR THE MESH WIRE OF ANY DEBRIS OR OTHER OBJECTS TO PROVIDE ADEQUATE FLOW FOR SUBSEQUENT RAINS. TAKE CARE NOT TO DAMAGE OR UNDERCUT THE WIRE MESH DURING SEDIMENT REMOVAL. REPLACE STONE AS NEEDED.

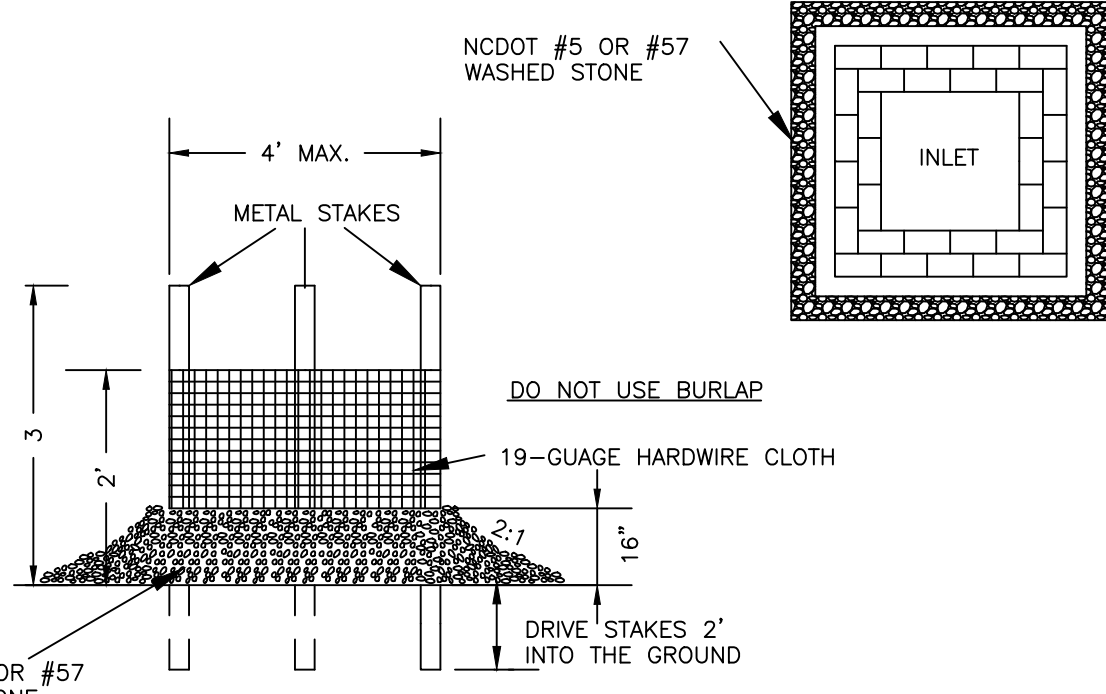

- CONSTRUCTION SPECIFICATIONS**
1. UNIFORMLY GRADE A SHALLOW DEPRESSION APPROACHING THE INLET.
  2. DRIVE 5-FOOT STEEL POSTS 2 FEET INTO THE GROUND SURROUNDING THE INLET. SPACE POSTS EVENLY AROUND THE PERIMETER OF THE INLET, A MAXIMUM OF 4 FEET APART.
  3. SURROUND THE POSTS WITH WIRE MESH HARDWARE CLOTH. SECURE THE WIRE MESH TO THE STEEL POSTS AT THE TOP, MIDDLE, AND BOTTOM. PLACING A 2-FOOT FLAP OF THE WIRE MESH UNDER THE GRAVEL FOR ANCHORING IS RECOMMENDED.
  4. PLACE CLEAN GRAVEL (NC DOT #5 OR #57 STONE) ON A 2:1 SLOPE WITH A HEIGHT OF 16 INCHES AROUND THE WIRE, AND SMOOTH TO AN EVEN GRADE.
  5. ONCE THE CONTRIBUTING DRAINAGE AREA HAS BEEN STABILIZED, REMOVE ACCUMULATED SEDIMENT, AND ESTABLISH FINAL GRADING ELEVATIONS.
  6. COMPACT THE AREA PROPERLY AND STABILIZED IT WITH GROUND COVER.

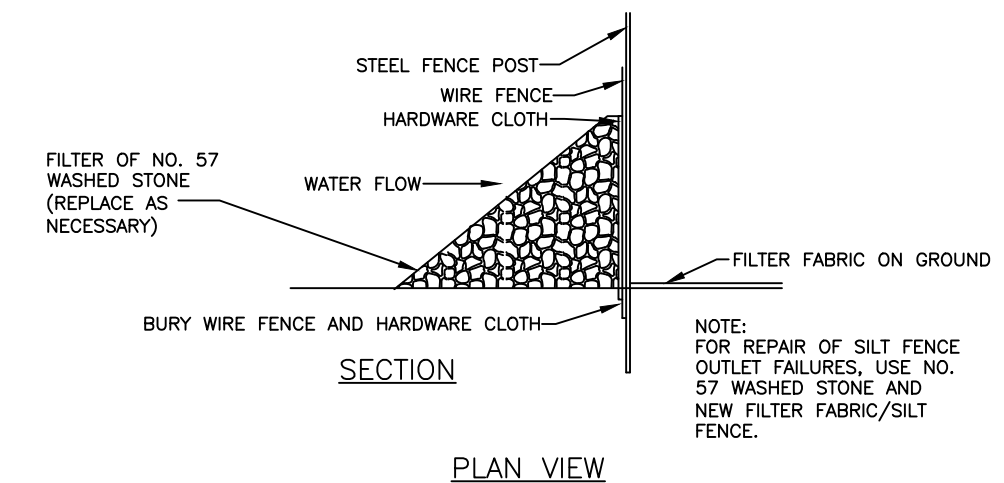

- MAINTENANCE**
- INSPECT SILT FENCE OUTLETS AT LEAST ONCE A WEEK AND AFTER EACH RAINFALL. MAKE ANY REQUIRED REPAIRS AS NEEDED. REMOVE SEDIMENT AS NECESSARY TO PROVIDE ADEQUATE STORAGE VOLUME FOR SUBSEQUENT RAINS. WHEN THE CONTRIBUTING DRAINAGE AREA HAS BEEN ADEQUATELY STABILIZED, REMOVE ALL MATERIALS AND ANY UNSTABLE SOIL, AND EITHER SALVAGE OR DISPOSE OF IT PROPERLY. BRING THE DISTURBED AREA TO PROPER GRADE, THEN SMOOTH AND COMPACT IT. STABILIZE AREAS AROUND THE OUTLET.

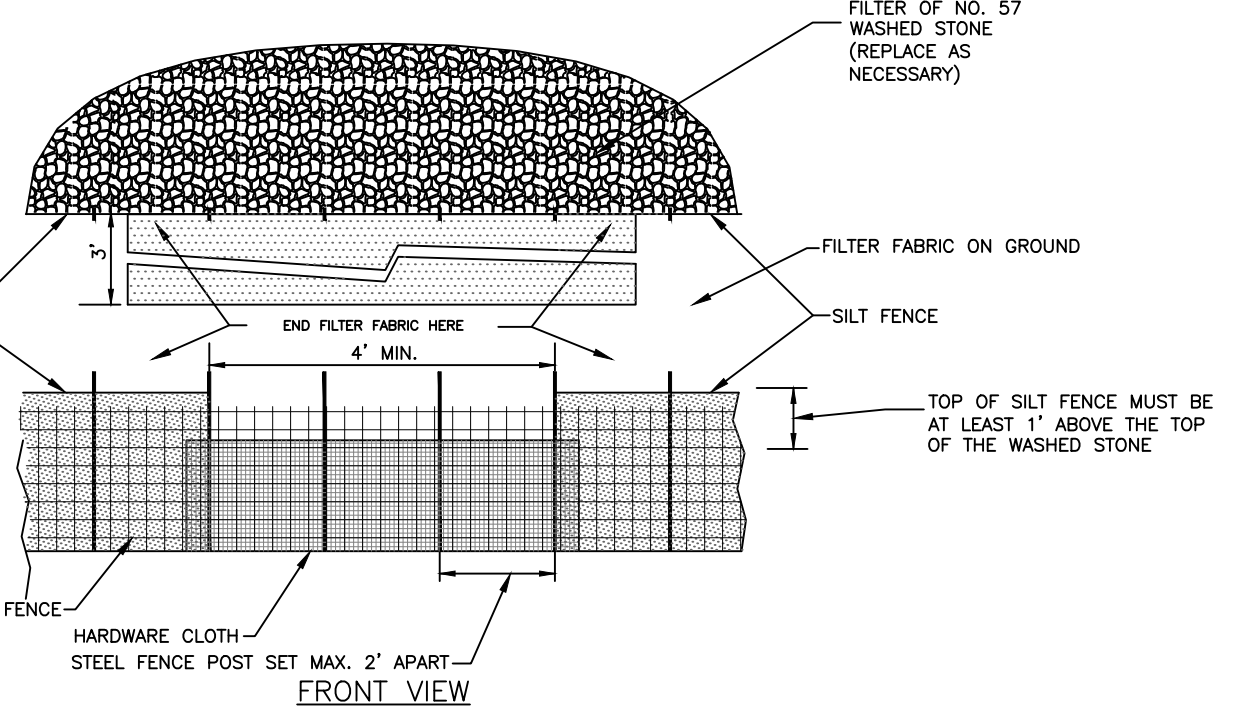

- INSTALLATION**
1. REMOVE OUTER WRAPPING.
  2. LOCATE BEGINNING OF ROLL WITH STARTER SHEET.
  3. MAKE SURE NETTING APPEARS ON TOP OF THE BLANKET WHEN BEING UNROLLED.
  4. STAPLE BLANKET SECURELY TO SOIL AS APPLIED.
- INSTRUCTIONS**
- THE EROSION CONTROL BLANKET SHOULD BE INSTALLED OVER A PROPERLY PREPARED, FERTILIZED, AND SEEDED AREA. WHEN THE BLANKET IS UNROLLED, THE NETTING SHOULD BE ON TOP AND THE BLANKET IN CONTACT WITH THE SOIL OVER THE ENTIRE AREA. IT IS NOT NECESSARY TO OVERLAP, DIG CHECK SLOTS, ANCHOR DITCHES, OR BURY THE ENDS OF THE BLANKETS.
- THE STAPLES SHOULD BE DRIVEN VERTICALLY INTO THE GROUND. EACH BLANKET SHALL BE STAPLED AT EACH EDGE AND ALTERNATELY SPACED IN THE CENTER OF EACH BLANKET. USE A COMMON ROW OF STAPLES AT THE SEAM FORMED BY TWO ADJOINING BLANKETS. USE FOUR STAPLES AT THE BEGINNING AND END OF EACH BLANKET.
- IN DITCHES: THE BLANKETS SHOULD BE APPLIED IN THE DIRECTION OF WATER FLOW, BUTTED TIGHTLY AT ENDS AND SIDES AND STAPLED IN PLACE. WHEN USING TWO OR MORE BLANKETS SIDE BY SIDE, DO NOT PLACE A SEAM FORMED BY EDGES OF ADJOINING BLANKETS DIRECTLY IN THE CENTER OF THE WATER FLOW.
- STAPLES SHOULD BE SPACED NO MORE THAN FOUR FEET APART DOWN THE LENGTH OF THE BLANKET. APPROXIMATELY 90 TO 95 STAPLES REQUIRED FOR EACH BLANKET.
- STAPLES: THE STAPLES SHALL BE MADE OF WIRE, .091" IN DIAMETER OR GREATER, "U" SHAPED WITH LEGS 6" IN LENGTH AND A 1" CROWN. SIZE AND GAUGE OF STAPLES USED WILL VARY WITH SOIL CONDITIONS.
- THE STAPLES SHALL BE DRIVEN VERTICALLY INTO THE GROUND, SPACED APPROXIMATELY TWO (2) LINEAL YARDS APART ON EACH SIDE, AND ONE ROW IN THE CENTER ALTERNATELY SPACED BETWEEN EACH SIDE (60 STAPLES ON EACH BLANKET). USE A COMMON ROW OF STAPLES ON ADJOINING BLANKETS.
- USE 4 STAPLES ACROSS AT THE START OF EACH ROLL AND CONTINUE TO STAPLE THROUGHOUT THE LENGTH AT 4 FT. INTERVALS IN AREAS WITH HIGH WATER VELOCITY. STAPLES SHOULD BE ON FOOT CENTERS.
- STAPLES WILL APPEAR AS A "5" ON DICE
- MAINTENANCE: INSPECT AT LEAST WEEKLY AND AFTER EACH RAIN OF 1/2" OR MORE. GOOD GROUND CONTACT WITH BLANKET MUST BE MAINTAINED. ANY AREAS FOUND DAMAGED OR NOT IN CLOSE CONTACT WITH THE GROUND SHALL BE REPAIRED AND STAPLED. REPAIR ANY ERODED AREAS IF FOUND. MONITOR UNTIL GRASS OVER ESTABLISHED.

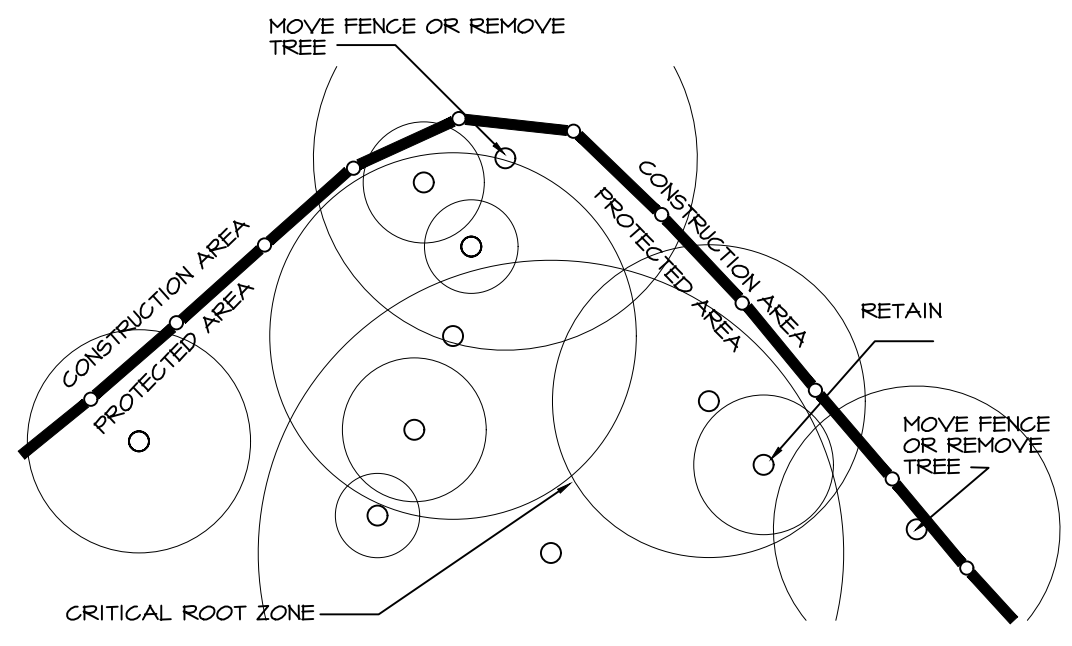

- NOTES:**
1. MOVE FENCE OR REMOVE TREE IF MORE THAN 20% OF A TREE'S CRITICAL ROOT AREA IS UNPROTECTED.
  2. ROOT PRUNE TREES TO REMAIN WHERE CONSTRUCTION ACTIVITIES WILL SEVER ROOTS.
  3. ANY TREE ROOTS EXPOSED BY CONSTRUCTION SHALL BE SEVERED CLEANLY WITH A PRUNING TOOL.
  4. DO NOT DISPOSE OF ANY CHEMICALS OR REMOVE SOIL OUTSIDE THE LIMITS OF WORK.
  5. WHEN INSTALLING NEW LANDSCAPE PLANTS, DO NOT DRIVE EQUIPMENT UPON OR DISTURB THE SOIL WITHIN THE CRITICAL ROOT ZONE OF EXISTING TREES.
  6. SIGNAGE MUST BE PLACED ON TREE PROTECTION FENCING WITH A MINIMUM MINIMUM SPACING OF 75' O.C., TO READ "TREE PROTECTION AREA - NO TRESPASSING WITHIN THE FENCE".

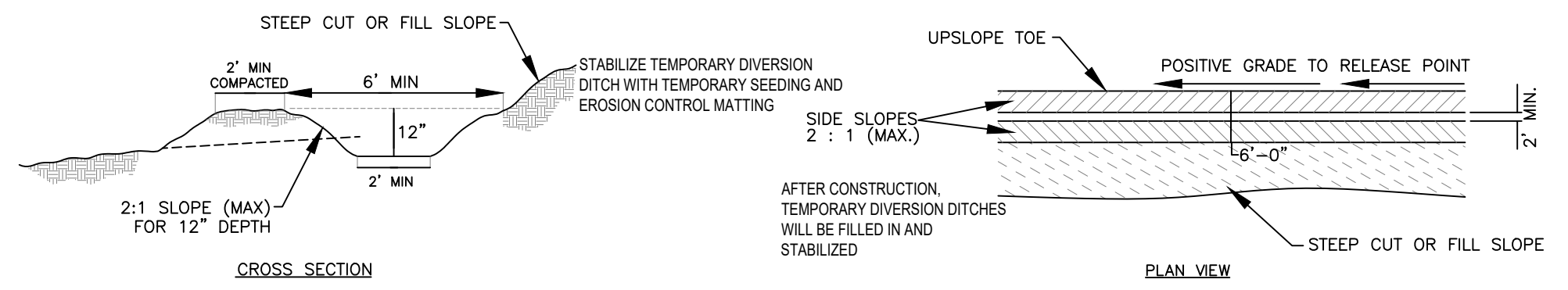
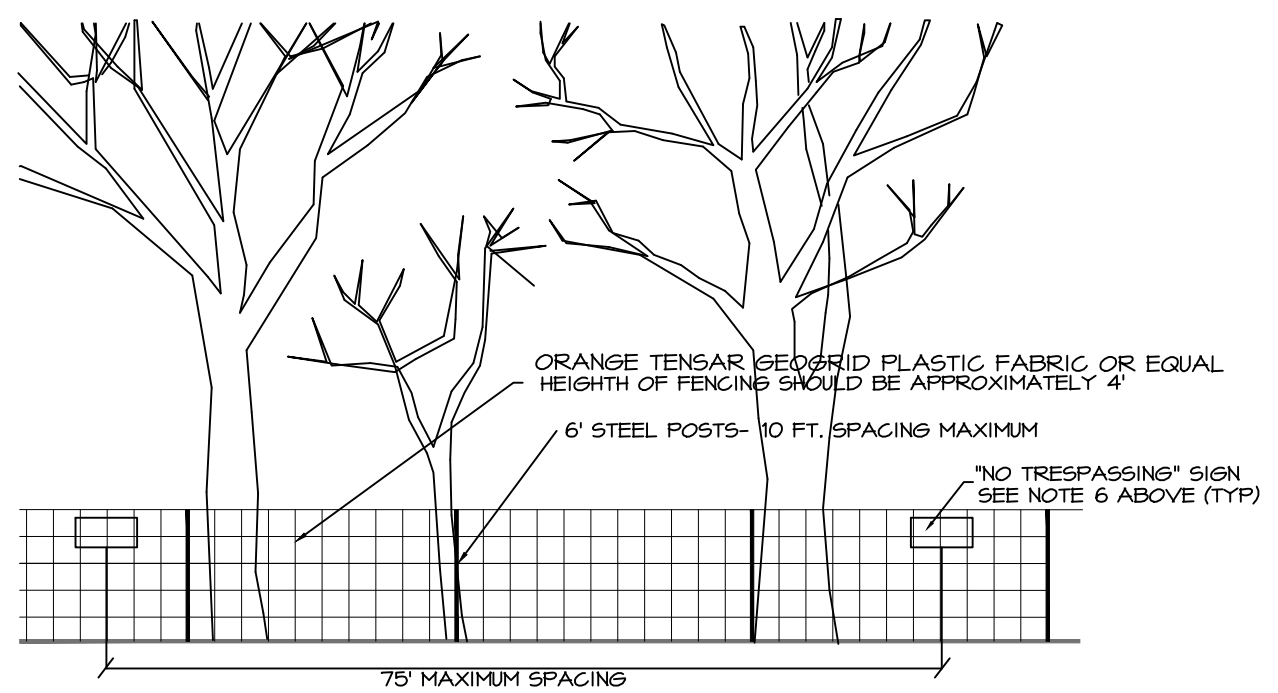

**Coulter Jewell Thames**

111 West Main Street  
Durham, N.C. 27701  
p 919.682.0368  
f 919.688.5646  
www.cjtpa.com

Project:  
**324 ROSEMARY MIXED-USE**

324 W ROSEMARY ST.  
CHAPEL HILL, NC 27516

ORANGE COUNTY  
NORTH CAROLINA

PIN: 9788178053

PRELIMINARY  
NOT FOR CONSTRUCTION

Job Number: 1663

Drawn: JSA, ED, TRM  
Checked: JSA  
Date: 04.20.2020  
Revisions:

EROSION CONTROL PLAN

Sheet Title:  
**EROSION CONTROL DETAILS**

Sheet Number  
**C701**

**CHAPEL HILL LAND USE MANAGEMENT ORDINANCE**

**3.8.3 EXCEPTIONS TO SETBACK AND HEIGHT REGULATIONS.**

(B) THE FOLLOWING FEATURES MAY PROJECT ABOVE THE BUILDING ENVELOPE DEFINED BY THE MAXIMUM HEIGHT LIMITATIONS AND ADDITIONAL SETBACK REQUIREMENTS CONTAINED IN RULES FOR INTERPRETATION OF TABLE 3.8-1, COLUMNS (F) AND (G), BELOW, PROVIDED THE TOWN MANAGER DETERMINES THAT SUCH FEATURES DO NOT SIGNIFICANTLY IMPAIR THE DEGREE OF SOLAR ACCESS PROVIDED ADJACENT PROPERTIES THROUGH APPLICATION OF THE APPROPRIATE SOLAR SETBACK REQUIREMENTS:

(1) CHIMNEYS, ACCESSORY RADIO OR TELEVISION ANTENNAS, FLAGPOLES, MONUMENTS, CUPOLAS, PARAPETS, DORMERS, CLOCK TOWERS OR DECORATIVE TOWERS WITH A FOOTPRINT NOT EXCEEDING TWENTY (20) PERCENT OF THE PRINCIPAL BUILDING, PROVIDED THE PROJECTION OF SUCH STRUCTURES ABOVE THE BUILDING ENVELOPE DOES NOT EXCEED FIFTEEN (15) PERCENT OF THE MAXIMUM HEIGHT LIMITATION THAT DEFINES THE PORTION OF THE BUILDING ENVELOPE PENETRATED BY SUCH STRUCTURES:

**DESIGN NOTES:**

- ALL ROOFS ARE WITHIN THE BUILDING ENVELOPE AS DEFINED BY THIS CODE, WITH PORTIONS ANGLED AT A 1:1 AND 1:1.7 SLOPE AS REQUIRED.
- ALL PARAPETS COMPLY WITH THE ABOVE REFERENCED EXCEPTION, NOT EXCEEDING 15% OF THE MAXIMUM HEIGHT LIMITATION.

**WEST ROSEMARY STREET DESIGN GUIDELINES**

THE PROJECT PROPOSES TO MEET THE GUIDELINES OF THE WEST ROSEMARY STREET DEVELOPMENT GUIDE IN THE FOLLOWING MANNER:

**PUBLIC REALM**

1. PROVIDING SUFFICIENT SPACE FOR PEDESTRIANS ALONG ROSEMARY ST.
2. PROVIDING IMPROVED AND CONTINUOUS SIDEWALKS ALONG ROSEMARY ST.
3. PROVIDING STREET TREES ALONG AT LEAST 60% OF THE BLOCK LENGTH.
4. EXISTING ROSEMARY ST LIGHTING IS ALREADY IN PLACE. ADDITIONAL LIGHTING WILL BE PROVIDED ON THE BUILDING FACADE TO CREATE A SAFE AND WELCOMING PEDESTRIAN EXPERIENCE.
5. INFRASTRUCTURE WILL BE SCREENED TO MINIMIZE VISIBILITY FROM THE PUBLIC RIGHT OF WAY.
6. PARKING IS PROPOSED TO BE STRUCTURED AND BELOW BUILDING AND WILL BE SCREENED TO MINIMIZE VISIBILITY FROM THE PUBLIC RIGHT OF WAY.
7. VEHICLE CURB CUTS ARE MINIMIZED SO AS TO PROVIDE SHARED ACCESS FOR ADJACENT PROPERTIES.

**BUILDING DESIGN**

1. A HORIZONTAL DATUM LINE IS CREATED THROUGH THE DESIGN OF THE PODIUM PLINTH (BELOW BUILDING PARKING LEVEL), AND THROUGH A FACADE RECESS AT THE FIRST MIXED-USE LEVEL FROM LEVELS ABOVE.
2. ALL BUILDING ENTRIES ARE PROVIDED OFF OF STREETS OR THE PODIUM PLINTH.
3. PEDESTRIAN SCALE SIGNAGE AND AMENITIES WILL BE CONSIDERED AND ENCOURAGED.
4. VERTICAL BAYS, VARIETY IN THE UPPER CORNICE HEIGHTS AND VISUAL BREAKS IN THE FACADE WILL BE CONSIDERED.
5. WHERE POSSIBLE, UTILITY SERVICES WILL BE LOCATED BELOW GROUND OR IN THE REAR OF THE SITE TO MINIMIZE VISIBILITY FROM THE PUBLIC RIGHT OF WAY.

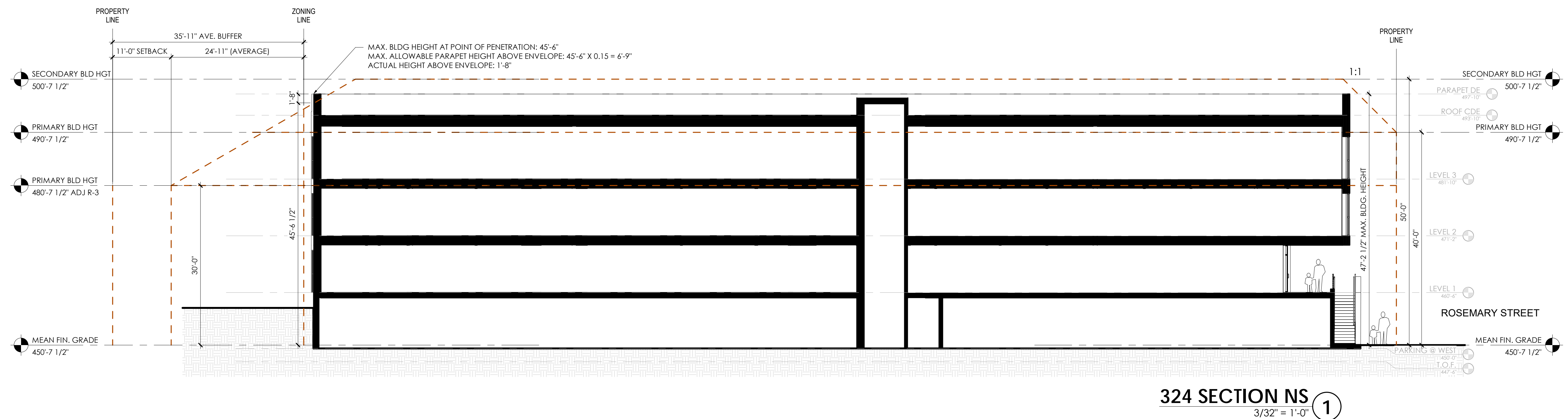
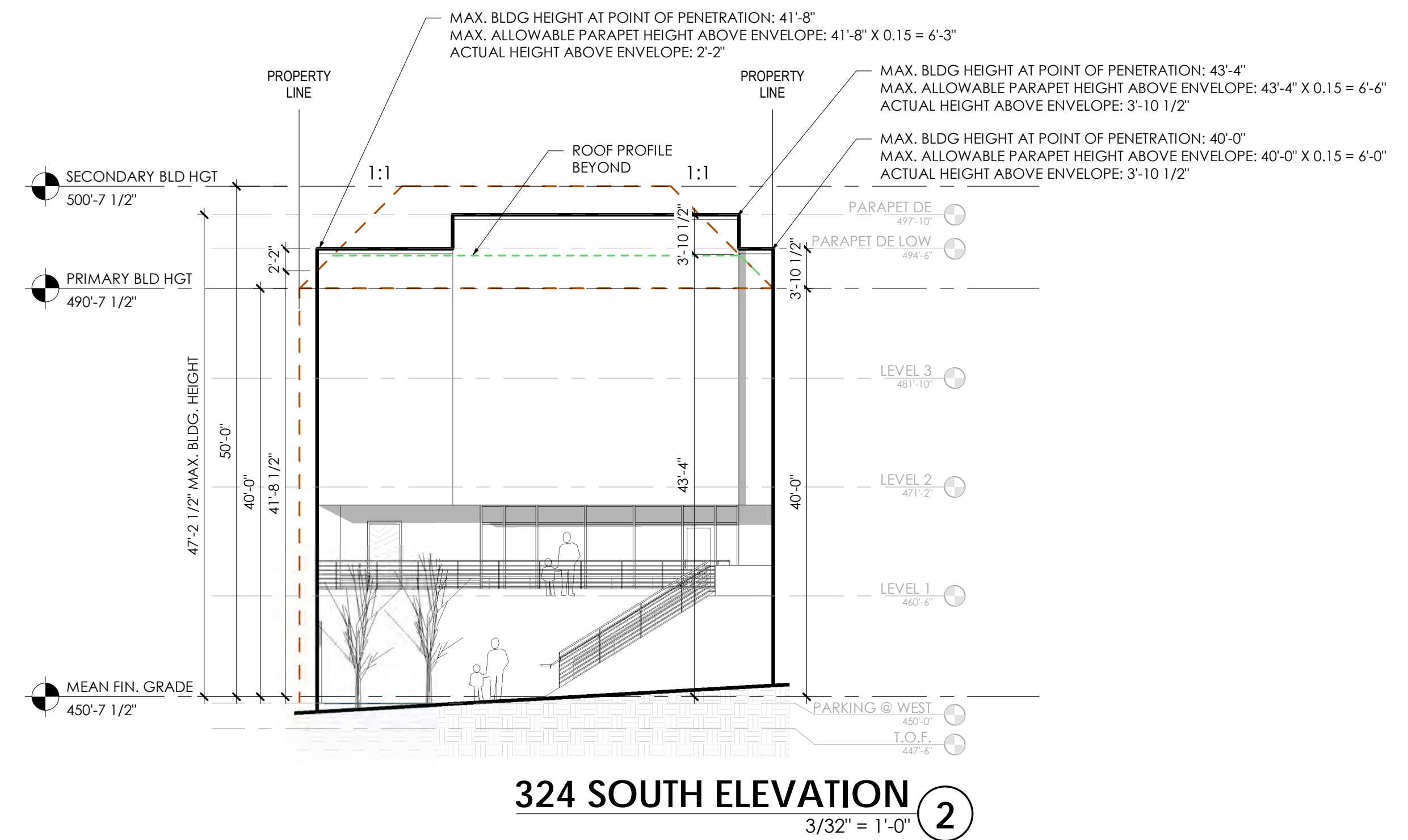

**FOR REVIEW ONLY**  
NOT FOR CONSTRUCTION

THESE DRAWINGS AND THE ACCOMPANYING SPECIFICATIONS ARE INSTRUMENTS OF SERVICE AND AS SUCH SHALL REMAIN THE PROPERTY OF THE ARCHITECT. THEY HAVE BEEN PREPARED FOR A SPECIFIC PROJECT AND SHALL NOT BE USED IN CONJUNCTION WITH ANY OTHER PROJECTS WITHOUT PRIOR WRITTEN PERMISSION OF THE ARCHITECT.  
©MHAworks 2020

SHEET NAME:  
**EXTERIOR ELEVATIONS AND BUILDING ENVELOPE**

PHASE:  
**PRE-DESIGN**

REVISIONS:

#	DESC.	DATE

ISSUE DATE: 04/21/20  
PROJECT #: 17045  
DRAWN BY: REK

SHEET NUMBER  
**324.AS1**