

DEVELOPMENT AGREEMENT

**BY AND BETWEEN
THE UNIVERSITY OF NORTH CAROLINA AT CHAPEL HILL, THE BOARD OF TRUSTEES
OF THE ENDOWMENT FUND OF THE UNIVERSITY OF NORTH CAROLINA AT CHAPEL
HILL, AND THE TOWN OF CHAPEL HILL**

AND

THE TOWN OF CHAPEL HILL, NORTH CAROLINA

Effective Date: JUNE 27, 2018

Orange County Parcel Identifier Numbers:

978-924-7373

978-903-3163

The Municipal Services Center - Campus Development Agreement

Table of Contents	Page
ARTICLE 1. STATUTORY FRAMEWORK	X
ARTICLE 2. DEFINITIONS.....	X
ARTICLE 3. RECITALS	X
ARTICLE 4. TERMS	X
ARTICLE 5. SPECIFIC STANDARDS AND MITIGATION MEASURES.....	X
EXHIBITS INCORPORATED BY REFERENCE	
EXHIBIT A.	Site Plan
EXHIBIT B.	Site Plan – Phase 1
EXHIBIT C.	Clearing Limits – Phase 1
EXHIBIT D.	Buffering and Landscaping – Phase 1
EXHIBIT E.	Sidewalks and Paths – Phase 1
EXHIBIT F.	Permitted Land Uses
EXHIBIT G.	Legal Description
EXHIBIT H.	Rezoning Application
EXHIBIT I.	Community Guiding Principles
EXHIBIT J.	Town Stream Determinations
EXHIBIT K.	Impact Analysis on the Value of Contiguous Properties of a Proposed Municipal Services Center
EXHIBIT L.	Site Development Permit Application
EXHIBIT M.	Elkin Hills Downstream Stormwater Project Area
EXHIBIT N.	Advisory Board Recommendations
EXHIBIT O.	Traffic Impact Study

STATE OF NORTH CAROLINA

COUNTY OF ORANGE

DEVELOPMENT AGREEMENT

This Development Agreement (hereinafter the “Agreement”) is made and entered into as of the 27th day of June, 2018 by and among The Town of Chapel Hill, a municipal corporation organized and existing under the laws of the State of North Carolina, and The University of North Carolina at Chapel Hill and the Board of Trustees of the Endowment Fund of The University of North Carolina at Chapel Hill, (collectively the “Developers”) and the Town of Chapel Hill (the Municipality).

ARTICLE 1. STATUTORY FRAMEWORK

1.1 G.S. 160A-400.20(b) and 160A-400.22 expressly authorize local governments and agencies to enter into development agreements with developers pursuant to the procedures and requirements of G.S. 160A-400.20 through 160A-400.32, which procedures and requirements include approval of the development agreement by the governing body of the local government by ordinance after a duly noticed public hearing.

1.2 In addition to any force of law conferred upon this Agreement by North Carolina law related to local governments, the terms of this Agreement are also contractual in nature, are a significant inducement and consideration to enter into this Agreement, and may be enforced as contractual terms.

ARTICLE 2. DEFINITIONS

In the construction of this Agreement and its incorporated EXHIBITs, the following capitalized terms shall have the respective meanings set forth below wherever they appear in this Agreement. Except as otherwise provided in this Agreement, terms used in the relevant portions of the North Carolina General Statutes or the Town of Chapel Hill Land Use Management Ordinance (“LUMO”) shall have the same meanings as employed in those statutes and ordinances.

2.1 *Agreement.* The word “Agreement” shall mean this Development Agreement.

2.2 *Annual Report.* The words “Annual Report” shall mean the annual report required by the Town pursuant to Section 5.25 of this Agreement.

2.3 *Council.* The word “Council” or “Town Council,” shall mean the legislative body of the Town of Chapel Hill, which together with the mayor of the Town shall constitute the governing body of the town.

2.4 *Development or Develop.* The words “Development” or “Develop” shall mean any activity on the Property involving, requiring, or consisting of: (i) the construction of a new building, and the construction or installation of other structures, roads, greenways or paved trails, sidewalks, parking lots, or utility infrastructures; (ii) the clearing or alteration of land as an adjunct of such construction; or (iii) the expansion of an existing building.

2.5 *Developer or Developers.* The words “Developer” or “Developers” shall mean the Town of Chapel Hill, the University of North Carolina at Chapel Hill, and the Endowment of the University of North

Carolina at Chapel Hill acting in the role of a developer and/or property owner.

- 2.6 *Effective Date.* The word “Effective Date” shall mean the effective date of this Agreement, which is June 27, 2018.
- 2.7 *LUMO.* The term “LUMO” shall mean the Land Use Management Ordinance of the Town of Chapel Hill in effect as of the Effective Date.
- 2.8 *Manager.* The words “Manager” or “Town Manager” shall mean the Town Manager of the Town of Chapel Hill or his/her designee and anyone acting pursuant to authority vested by state statute or local ordinance to issue local permits for Development on behalf of the Town of Chapel Hill.
- 2.9 *Municipality.* “Municipality” shall mean and refer to the Town of Chapel Hill, a municipal corporation organized under the laws of the State of North Carolina when acting in its capacity as the governing municipality for this Development Agreement, site plan approval, special use permits, building permits or other required approvals under the laws, rules and regulations adopted by the Town of Chapel Hill or other governmental authority.
- 2.10 *Nontechnical and technical words.* Words and phrases shall be construed according to the common and approved usage of the language, but technical words and phrases and such others as may have acquired a peculiar and appropriate meaning in law shall be construed and understood according to such meaning.
- 2.11 *Party.* The word “Party” shall mean one or more of the “Parties” as may be understood based on the specific context of the reference.
- 2.12 *Parties.* The word “Parties” shall mean the Town of Chapel Hill, the University of North Carolina at Chapel Hill, and the University and the Municipality.
- 2.13 *Periodic Review.* The term “Periodic Review” shall have the meaning ascribed in Section 4.12 of this Agreement.
- 2.14 *Property.* The term “Property” shall mean that certain parcel of land, located on Estes Drive as depicted in EXHIBIT A, attached hereto. The Property also includes any public rights-of-way that may be located within the boundaries of EXHIBIT A.
- 2.15 *Registry.* The term “Registry” shall mean the Orange County Register of Deeds.
- 2.16 *Site Development Permit, or SDP.* The words “Site Development Permit” shall mean the permit issued by the Town Manager authorizing Development or portions thereof in accordance with this Agreement. A Site Development Permit required by this Agreement shall be in lieu of any Zoning Compliance Permit that might otherwise be required by Section 4.9 of the LUMO.
- 2.17 *State.* The term “State” shall mean the State of North Carolina.
- 2.18 *Town.* The word “Town” shall mean and refer to the Town of Chapel Hill, a North Carolina municipal corporation or its successor, solely in its capacity as a *participant* and not as the governing municipality.
- 2.19 *Town Attorney.* The term “Town Attorney” shall mean the attorney for the Municipality.

2.20 *Town Regulations*. The term “Town Regulations” shall have the meaning as described in Section 4.4.

2.21 *University*. The words “the University” shall mean the University of North Carolina at Chapel Hill and The Board of Trustees of the Endowment Fund of The University of North Carolina at Chapel Hill.

2.22 *Zoning Compliance Permit*. The term “Zoning Compliance Permit” or “ZCP” shall mean an administrative permit issued by the town manager authorizing the recipient to make use of existing buildings in accord with the requirements of the Land Use Management Ordinance as of the effective date of this Agreement.

ARTICLE 3. RECITALS

- 3.1 The University of North Carolina at Chapel Hill through the State of North Carolina, and The Board of Trustees of the Endowment Fund of The University of North Carolina at Chapel Hill are the owners of that certain property situated on the southern side of Estes Drive as shown on EXHIBIT A and described on EXHIBIT G. The Property is located within the corporate and regulatory limits of the Town of Chapel Hill.
- 3.2 On September 27, 2017 the Town Council directed the Town Manager and Town Attorney to negotiate a development agreement for the redevelopment of the *Property*.
- 3.3 On May 10, 2017 the Town created a web page on the Town of Chapel Hill website to provide information about the proposal.
- 3.4 On March 6, 2017 and September 7, 2017, the Town hosted public information meetings to learn about the proposal.
- 3.5 On November 30 and December 13 of 2017, and January 8, February 5, February 15, March 1, and April 12, 2018, the Town hosted public workshops to receive public input regarding specific topics about the project. The topics for these meetings were developed with interested community members following the September 7, 2017 public information meeting.
- 3.6 Residents of the Elkin Hills neighborhood participated in community meetings and developed a document consisting of Guiding Principles for the Development Agreement. The principles have served as design drivers for the site layout, and have been broadly incorporated into the program for development. Specific incorporation of portions of the Guiding Principles are in the following sections of this Agreement: 5.4, 5.5, 5.7, 5.8, 5.10, 5.17, 5.18, and 5.22.
- 3.7 An impact analysis on the value of contiguous properties was performed by a NC State-Certified General Real Estate Appraiser. This report was provided to the Town and interested residents. The report is provided as an Exhibit to the Agreement.
- 3.8 The following advisory boards reviewed and provided their feedback on the development agreement:

The Community Design Commission and the Transportation and Connectivity Advisory Board both met on March 27, 2018; the Environmental Stewardship Advisory Board met on April 10, 2018; and the Planning Commission met on April 17, 2018.

The Parks, Greenways, and Recreation Commission reviewed and provided feedback on April 17, 2018, and the Stormwater Management Utility Advisory Board reviewed and provided feedback on April 24, 2018.
- 3.9 The purpose of this Agreement is to facilitate the Development of the Property in a way that best realizes the public benefits to the Town of Chapel Hill and the University of North Carolina at Chapel Hill. The Development of the Property requires a major investment by the first builder, presumed to be the Town, in facilities, substantial front-end investment in infrastructure improvements, and substantial commitments of the resources to achieve the benefits of the Development for the Town, and the University. The Town will be unable to make and realize the benefits from such commitments without the assurances as provided by this Agreement.

- 3.10 The general benefits to be received by the Town of Chapel Hill from the implementation of the Development include, without limitation:
- a) The opportunity to build a municipal services center in a desirable location for serving the needs of the entire community,
 - b) Minimization of adverse off-site impacts, and incorporation of sustainability principles in the design and implementation of the Development of the Property;
 - c) Provision of a plan for addressing the transportation needs of the Development of the Property, including commitments of sidewalks, a Greenway connection, and road improvements; and
 - d) Assurance that the long term Development of the Property will be undertaken in a manner that is compatible with the interests of the Town and the University.
- 3.11 The general benefits to be received by the University from the implementation of the Development include without limitation:
- a) Obtaining sufficient certainty, timeliness, and predictability in the Town's development review and approval process to justify the substantial up- front capital investment by the Town on University-owned property;
 - b) Integration of site plans, and uses, architecture, site engineering, landscape architecture, and mitigation measures over the entire Property;
 - c) Flexibility and alternatives to Town ordinances, standards, policies and guidelines to achieve the Development; and
 - d) Participation from the Town to achieve the public benefits necessary for the Development including stormwater management infrastructure.
- 3.12 In exchange for providing these benefits mutual benefits, both parties receive the assurance that they may proceed with the Development of the Property in accordance with any and all existing Town of Chapel Hill development regulations and conditions of approval of the Municipality as they exist on the Effective Date, subject to the terms, conditions, and exceptions contained herein and subject to periodic potential amendments to this Agreement made in accordance with this Agreement.
- 3.13 After careful review and deliberation, the Parties have determined that the latitude afforded the proposed Development of the Property and the certainty, timeliness, and predictability regarding Town development approval afforded by this Agreement provide important benefits and Development justifies the provision of the mitigation measures specified in Article 5 of this Agreement, which the Parties freely and with full knowledge and consent agree to provide.
- 3.14 The terms and conditions of this Agreement have undergone review by the Town's staff and the Town Council and have been found to be fair, just, and reasonable. After careful review and deliberation, the Town Council has determined and concluded that the Agreement meets the goals and needs of the Town and the University and complies with all statutory requirements.
- 3.15 The Town of Chapel Hill, by electing to enter into this Agreement in accordance with statutory procedures, acknowledges that the obligations of the Town of Chapel Hill shall survive beyond the term or terms of the present Town Council and that such action will serve to bind the Town of Chapel Hill and future councils to the obligations thereby undertaken. By approving this Agreement, the Municipality has elected to exercise certain governmental powers at the time of entering into this Agreement rather than deferring its actions to some undetermined future date.
- 3.16 Based on the foregoing considerations, the Parties desire to enter into this Agreement for the

purposes of:

- a) agreeing upon the plan, design, and density of Development on the Property and the types of uses thereon, and promoting sustainability, reflecting consideration of economic issues;
- b) coordinating the construction and provision of infrastructure that will serve the above-described Development of the Property and the community at large;
- c) confirming the dedication and/or provision of the public amenities described herein; and
- d) providing assurances to the Parties that they may proceed with the Development of the Property in accordance with the terms of this Agreement without encountering future changes in ordinances, regulations or policies that would affect their ability to Develop the Property under the terms of this Agreement;
- e) providing certainty that the Parties can obtain permits necessary for the Development pursuant to a non-discretionary, predictable and expeditious process.

3.17 Pursuant to G.S. 160A-400.24, the Town Council conducted a public hearing on May 9, 2018 to consider the approval of this Agreement. The notice of public hearing specified, among other things, the location of the Property subject to this Agreement, and the development uses proposed on the Property. The initial draft of this Agreement was posted on the Town website on March 28, 2018 and was available for public inspection at Town offices and online at that time. Updates to the draft of this Agreement were posted for the May 9, 2018 public hearing.

3.18 On June 27, 2018 the Town Council considered and approved this Agreement and authorized the Town's execution of the same as a Party and as the Municipality. The approval of this Agreement constitutes a legislative act of the Municipality's Town Council.

ARTICLE 4. TERMS

NOW, THEREFORE, based upon the terms and conditions set forth herein and in consideration of the mutual promises and assurances provided herein, the Parties do hereby agree as follows:

- 4.1. Recitals. The Parties agree the foregoing Recitals in Article 3 are true and correct and are incorporated herein by reference.
- 4.2. Property Subject to Agreement. The real property subject to this Agreement includes all of the Property.
- 4.3. Zoning of the Property. On June 27, 2018, the Town Council rezoned the Property to University-1 (U-1) which is located within the Town's planning and zoning jurisdiction.
- 4.4. Term of Agreement: The term of this Agreement shall commence upon the Effective Date, and it shall expire twenty (20) years thereafter unless sooner terminated by the mutual consent of the parties hereto or their successors in interest or is otherwise terminated pursuant to the terms of this Agreement. This twenty- (20-) year term has been established as the maximum lease length currently permitted by the University. The Town finds that a term of twenty (20) years is reasonably necessary to assure the Town of the realization of the public benefits from the Project. Expiration of the twenty- (20-) year term shall not terminate mutually agreed to obligations and commitments included within this Agreement that are expressly specified to extend beyond the term of the Agreement. The term of this Agreement may be extended at any time by mutual agreement between the Parties of this agreement.

4.5. Law in Effect at Time of the Agreement Governs the Development; Vested Rights. Except as provided in G.S. 160A-400.26 and G.S. 160A-400.29(b), the Municipality may not apply subsequently adopted ordinances or development policies to the Property during the term of this Agreement without the written consent of the Parties. The consent of Parcel Owners shall not be required unless the Parcel owned by the Parcel Owner is directly and adversely affected by such subsequently adopted ordinances or development policies, in which case the affected Parcel Owner must also provide written consent under this Section. Accordingly, during the term of this Agreement the Parties shall have a vested right to Develop the Property in accordance with the terms of Article 5 of this Agreement, the terms of the LUMO, and any applicable laws and regulations, all of the foregoing as they exist as of the Effective Date. This Agreement does not abrogate any rights that may vest pursuant to statutory or common law or otherwise in the absence of this Agreement. The Participants agree, intend, and understand that the obligations imposed by this Agreement are only such as are consistent with state and federal law. In accordance with G.S. 160A-400.26(c), in the event state or federal law is changed after the Effective Date and the change prevents or precludes compliance with one or more provisions of this Agreement, the Town may modify the affected provisions with the consent of the Parties, upon a finding that the change in state or federal law has a fundamental effect on the Agreement, by ordinance after notice and a hearing and upon such modification the Town shall record the modification in the Registry. If the Parties fail to consent, this Agreement shall be terminated (with any Parties retaining any rights with respect to any Site Development Permit obtained prior to termination) and said termination will be recorded in the Registry.

4.6 Development of the Property - Special Uses. In the event a proposed Development does not comply with this Agreement and applicable Town Regulations and is not considered a Minor Modification (as hereinafter defined) to this Agreement, the applicant, in the applicant's sole discretion, may:

- a) apply to the Town Council for an amendment to this Agreement as a Major Modification (as hereinafter defined), or
- b) apply for a special use permit under Section 4.5 of the LUMO to permit the proposed Development.

4.7 Local Development Permits.

- a) In accordance with G.S. 160A-400.25(a)(6), the local development permits approved or needed to be approved for the Development shall include the following: (1) Individual Site Development Permits; (2) Building and other applicable construction permits; and (3) Engineering Construction Permits, Street Cut Permits, Street Closure Permits for work in public rights of way. Any such approvals and permits shall be consistent with the requirements of Article 5 of this Agreement. The failure of this Agreement to address a particular permit, condition, term or restriction does not relieve the Parties of the necessity of complying with such permitting requirements, conditions, terms or restrictions, except as may be limited or otherwise provided in this Agreement.
- b) Application may be made for more than one type of local permit at a time, and such permit applications shall be reviewed concurrently by the Town to the extent possible. Additionally, the Municipality shall exercise reasonable diligence to expedite the processing of the required permit and approval applications for the Development of the Property. The Parties shall in a timely manner provide the Town with all documents, applications, plans, and other information necessary for the Municipality to carry out its obligations hereunder.

4.8 Development of the Property – Site Development Permit.

- a) Permit Required. A Site Development Permit shall be required prior to the commencement of any Development or construction work related to Development except as otherwise indicated in this Agreement. The Site Development Permit required by this section shall be in lieu of any Zoning Compliance Permit that might otherwise be required by Section 4.9 of the LUMO. The Parties and/or Parcel Owners intending to undertake Development of the Property (the “Applicant”) shall apply for a Site Development Permit by filing the application provided for in EXHIBIT L.
- b) Schedule of Review:
- i. Prior to submitting an application for a Site Development Permit, the Party shall meet with the Municipality to review the proposed Development.
 - ii. Upon submittal of a Site Development Permit, Town projects shall be scheduled for Community Design Commission review, and University projects shall be scheduled for Design Review Committee review. The Community Design Commission shall have the option to review and provide comment on Town projects prior to a Site Development Permit approval.
 - iii. Within five (5) working days following submission of an application for a Site Development Permit, the Municipality shall provide the applicant with a completeness determination.
 - iv. The Municipality shall review the application for compliance with this Agreement and the applicable Town regulations that are not expressly superseded by this Agreement.
 - v. Within twenty (20) working days following the date on which an application is deemed complete, the Town shall provide written comments to the Party regarding whether the submitted application is in compliance with this Agreement and applicable Town regulations or whether the submitted application requires revision.
 - vi. If the application is not in compliance, the Party shall submit a revised application to the Town. Upon submitting a revised application, the Town shall process the revised application in the manner described in Section 4.8, including the twenty- (20-) day time frame set forth in subsection 5) and such process shall be repeated until the application is in compliance with this Agreement and applicable Town regulations. Throughout this review period, the Party and the Municipality will strive to review and respond to information in an expeditious manner and provide updates to one another every ten (10) working days to ensure open communication and accountability.
 - vii. The Town Manager shall approve the application upon finding it complies with and does not violate any term of this Agreement and the applicable Town regulations, and shall deny the application upon finding it does not comply with the terms of this Agreement and the applicable Town regulations.
 - viii. If the application is approved, the Town shall issue the Applicant a Compliance with Development Agreement Approval Letter.
 - ix. If the application is denied, the Town Manager shall specify the grounds for finding that it is inconsistent or in violation and refer the Party to the special use permit process described in Section 4.5 of the LUMO. Alternatively, the applicant may modify the Site Development Permit application or apply for Major Modification to this Agreement.
 - x. Notwithstanding anything to the contrary, a one-time change in floor area of one thousand (1,000) square feet or fewer to Development previously approved with a SDP shall not require modification or approval of another SDP. Such changes shall be reported

to the Municipality in the Annual Report.

- c) Construction Management Plan. Each Site Development Permit application shall include a construction management plan. The construction management plan shall, at a minimum:
- i. Show how construction vehicle traffic will be managed and where the construction vehicle routes will be located.
 - ii. Identify any impacts to bicycle, pedestrian, or Transit routes and facilities and indicate how they will be mitigated.
 - iii. Show parking areas for on-site construction workers including plans to prohibit parking in residential neighborhoods.
 - iv. Identify construction staging and material storage areas.
 - v. Identify construction trailers and other associated temporary construction management structures.
 - vi. Indicate how the project construction will comply with the Town's Noise Ordinance.
 - vii. Propose times and days when construction and noise from the Development are permitted.
 - viii. Indicate that the construction management plan for a project will provide a phone number for noise notifications during the construction period. The Party will contact adjoining property owners directly prior to construction and will post a sign on-site and in the neighborhood, in public right-of-way or an alternate, visible location agreeable to adjoining property owners, stating that noise issues can be reported by calling the posted phone number.
 - ix. Submit written confirmation that the Party has provided information to contractors and subcontractors regarding noise mitigation requirements for Development for contractor and subcontractor review and compliance with same.
 - x. If initial site clearing is proposed during the Spring season, the developer shall consider methods to reduce the impact to nesting birds.

4.9 Amendment and Modification. The terms of this Agreement may be amended or modified by the mutual consent of the Parties, A modification of this Agreement that is considered a Major Modification (as hereinafter defined) of the terms of this Agreement shall follow the same procedures as required by North Carolina law for the adoption of a development agreement. Any Party may propose a Major Modification requiring amendment or a Minor Modification (as hereinafter defined) to this Agreement. Upon receipt of a proposed modification, the Town Manager shall consider the following criteria in making the determination as to whether a proposed modification is a Major Modification or a Minor Modification to this Agreement. The following changes (a) – (g) will be considered Major Modifications under the Agreement:

- a) A substantial change in the boundaries of Property subject to this Agreement as defined as:
 - i. any single proposed increase or decrease in the area of land subject to this Agreement of more than five (5) percent, or
 - ii. a cumulative increase of ten (10) percent or more in the land area subject to this Agreement.
- b) An increase in the amount of total square footage of greater than five (5) percent
- c) An increase in maximum building stories

- d) Any decrease in the proposed stormwater management standards
- e) Any encroachment into the 100 foot buffer other than the uses contemplated in this Agreement.
- f) Locating a building that is designated to be located internally within the site to the south or east of the internal loop road.
- g) Construction of a fire station or other uses not included on Exhibit F
- h) Any increase in the number of vehicular parking spaces.

All other amendments or modifications to this Agreement are considered Minor Modifications and therefore would not require the procedures for adoption of a development agreement. All Minor Modifications require notice to Town Council and shall be subject to review and approval by the Town Manager. Such approval shall be memorialized by letter from the Town Manager and acknowledged by the Parties and shall be maintained on file by the Town Clerk if applicable.

Notwithstanding the above, some proposed changes to this Agreement that do not meet the threshold to constitute a Major Modification may in the judgment of the Town Manager, because of size, perimeter location or transportation impacts, merit public review. In the event the Town Manager makes such a determination, the Town Manager may submit a proposed Minor Modification as notification to Town Council to allow an opportunity for Council review. Unless the Parties agree otherwise, such a review shall not extend the time period allowed for a decision by the Town Manager on the Minor Modification or convert the change from a Minor Modification into a Major Modification.

All proposed adjustments to this Agreement shall be publicly posted in such a manner that citizens of Chapel Hill will have the opportunity to express any concerns to the Town Council and/or the Town Manager.

- i) The Town Manager shall determine whether a proposed adjustment to this Agreement is a Major Modification or a Minor Modification within fifteen- (15-) working days of receipt of a proposed adjustment and shall promptly notify the Town Council and applicant of that determination. If the proposed action is determined to be a Major Modification, the Town Manager shall require the filing of an application for approval of the amendment, following procedures outlined in Section 1.6 of this Agreement.
- j) Minor Modifications to this Agreement may be approved by the Town Manager as long as such changes continue to be in substantial compliance with the approving action of the Town Council and all other applicable requirements and result in a configuration of buildings/development that is generally consistent with this Agreement. The Town Manager shall not have the authority to approve changes that constitute a Major Modification to this Agreement.

4.10 Recordation/Binding Effect. Within fourteen (14) days after the Town of Chapel Hill and University enter into this Agreement, the Municipality shall record this Agreement in the Registry. The burdens of this Agreement shall be binding upon, and the benefits of this Agreement shall inure to the Town and its successors in interest, to the Parties and their successors and assigns in title (as defined in Section 4.23). All of the provisions of this Agreement shall be enforceable during the term as equitable servitudes and constitute covenants running with the land pursuant to applicable law.

4.11 Annual Report. The Parties or their designee shall on an annual basis for five consecutive years or until construction is completed submit a written report to the Town Manager on the Development undertaken pursuant to this Agreement in the previous year (the "Annual Report"). The Annual Report shall set forth all individual Site Development Permits issued, infrastructure installed, the

status of participation by the Parties in the provision of or financing of public infrastructure for the Development, dedications and acquisitions of infrastructure by the Parties and the projected schedule for Development of the Property in the forthcoming year. The Annual Report shall include all of the information required pursuant to Section 5.25 of the Agreement and shall be provided at the times specified by that Section. The Annual Report shall also include a report demonstrating good faith compliance by the Parties with the terms of this Agreement. Upon receipt of the Annual Report, the Town Manager shall undertake the Periodic Review as set forth in Section 4.12 of this Agreement. For so long as the Town of Chapel Hill is the sole occupant of the Property, the Town of Chapel Hill agrees to prepare and submit the Annual Report, subject to the review and approval of the University prior to submission.

4.12 Periodic Compliance Review and Enforcement.

- a) Periodic Review. Pursuant to G.S. 160A-400.27, the Town Manager shall conduct a periodic compliance review (the “Periodic Review”) at least every twelve (12) months for five consecutive years or until construction is completed, at which time the Parties shall be required to demonstrate good faith compliance with the terms of this Agreement. The Town Manager shall promptly report the results of this review to the Town Council. The Town Manager will use the Annual Report as the basis for preparing the Periodic Review.
- b) Periods of Inactivity If there has been no significant activity on the Property for twelve months, the Parties may submit a statement to that effect in lieu of the Annual Report.
- c) Material Breach. If, as a result of the Periodic Review, the Town Council finds and determines that any Party has committed a material breach of the terms or conditions of the Agreement (the “Breaching Owner”), the Town Manager shall serve notice in writing to the Breaching Party within fifteen (15) days after the Periodic Review setting forth with reasonable particularity the nature of the breach and the evidence supporting the finding and determination.
- d) Right to Cure. After Notice has been served, the Breaching Party shall have a reasonable time in which to cure the material breach (the “Breaching Owner’s Cure”), but in no event shall the Breaching Party have less than thirty (30) days for the Breaching Party’s Cure. Notwithstanding the foregoing, the Breaching Party, as applicable, shall be afforded an additional reasonable period of time to cure the breach if cure is commenced within the time period and thereafter diligently pursued but cannot be completed within said time frame.
- e) Termination or Modification by the Town. If the Breaching Party fails to cure the material breach under Section 4.12(c), then the Town Council may elect to terminate or modify the Agreement after complying with mediation requirements as stated in Section 4.13. Any notice of termination or modification or finding of breach by the Town may be appealed to the Town Board of Adjustment in the manner provided by G.S. 160A-388(b1). Thereafter, the Breaching Party may pursue any other rights and remedies available at law or in equity. If after mediation the Town Council elects to unilaterally modify the Agreement, the Parties may elect for the Agreement to be terminated rather than accede to the Agreement with the modifications made by the Town Council by giving written notice to the Town within sixty (60) days after the proposed modification. In such an event, Section 4.27(a) and Section 4.27(b) shall apply and the Party has the right to file a termination in the Registry. Failure of the Town to conduct this Periodic Review shall not constitute a waiver by the Town of its rights to otherwise enforce the provisions of this Agreement, nor shall the Parties have or assert any defense to such enforcement by reason of such failure to conduct a Periodic Review.

- 4.13 Mediation. In the event any Developer believes another Developer is in default or is in material breach, the Developers shall make a good faith effort to negotiate and informally resolve the issues in dispute prior to terminating this Agreement. In the event of an impasse between the Participants in reaching any mutual agreement mandated by this Agreement, the Developers shall make good

faith efforts to negotiate and informally resolve the issue in dispute (the “Claim”). If the Developers do not resolve the Claim through negotiation within 30 days of the date of the notice of default, the Developers agree to submit the claim to mediation pursuant to the following process:

- a) The non-defaulting Developer (the “Claimant”) shall have thirty (30) additional days within which to submit the Claim to mediation under the auspices of any dispute resolution center or other such independent agency providing similar services upon which the Participants may mutually agree.
- b) If Claimant does not submit the claim to mediation within thirty (30) days after notice of default, Claimant shall be deemed to have waived the claim, and the defaulting Developer (the “Respondent”) shall be released and discharged from any and all liability to Claimant on account of such claim; provided, nothing herein shall release or discharge Respondent from any liability to Persons not a participant to the foregoing proceedings.
- c) If the Developers do not settle the Claim within thirty (30) days after submission of the matter to the mediation process, or within such time as determined reasonable or appropriate by the mediator, the mediator shall issue a notice of termination of the mediation proceedings. Such notice shall set forth when and where the Developers met, that the Participants are at an impasse, and the date that mediation was terminated.
- d) If settlement does not occur and mediation is terminated, the Developers may pursue any and all actions at law and equity permitted under this Agreement subject to the right to notice and cure as provided in Section 4.12.

4.14 Development Timing and Moratoria. The Parties may, but shall not be obligated to, develop the Property pursuant to this Agreement. If any Party so elects to develop a portion of the Property, such Participant shall carry out the Development of such portion of the Property in such order and sequence as the Parties determine in its discretion, provided such does not violate an express provision of this Agreement. Phasing of the Development shall be based on sound engineering to ensure functional and safe street circulation and utility systems at all times. Phasing shall be based in such a way that all infrastructure improvements to be constructed within the Property will be provided when or before they are necessary for that phase of the Development. Absent an imminent threat to public health or safety, neither the right to develop nor the timing of Development shall be affected by a moratorium or suspension of development rights adopted by the Town except to the extent imposed by this Agreement or by supervening federal or state law, order, rule or regulation.

4.15 Default. Apart from the Periodic Review process set forth in Section 4.12 of this Agreement, the failure of the Parties to comply with the terms of this Agreement shall constitute a default, entitling the non-defaulting Developer or Developers to pursue such remedies as allowed under applicable law against the defaulting party, after following mediation requirements in Section 4.13 above, provided, however, that no termination of this Agreement may be declared by the Town of Chapel Hill or the University absent its according to the Parties, the notice and opportunity to cure set out in Section 4.12 of this Agreement.

4.16 Force Majeure. In addition to specific provisions of this Agreement, neither the University nor the Town of Chapel Hill shall be responsible for any default, delay or failure to perform if such default, delay or failure to perform is due to causes beyond such Participant’s reasonable control, including, but not limited to, strikes, lockouts, actions or inactions of governmental authorities (excluding Participating Parties to this Agreement), epidemics, wars, embargoes, fires, hurricanes, adverse weather, acts of God, interference duly caused by any other Participant, or the default of a common carrier. In the event of a default, delay or failure to perform due to causes beyond such Party’s reasonable control or due to interference by another Party, any date or times by which the Parties are otherwise scheduled to perform, if any, shall be extended automatically for a period of time equal in

duration to the time lost by reason of the cause beyond the reasonable control of such Participant. If written notice of such delay is given to the other Party after the commencement of such delay, an extension of time for such cause shall be deemed granted and will be agreed to by the Parties in writing for the period of the enforced delay, or longer as may be mutually agreed.

- 4.17 Disclaimer of Joint Venture, Partnership and Agency. This Agreement shall not be interpreted or construed to create an association, joint venture, or partnership between the University, the Endowment and the Municipality, or to impose any partnership obligation or liability upon such participating Parties. Neither the University nor the Town shall have any right, power or authority to enter into any agreement or undertaking for, or act on behalf of, or to act as or be an agent or representative of, or to otherwise bind, the other Party as provided in this Agreement.
- 4.18 No Third Party Beneficiaries. The Agreement is not intended to and does not confer any right or benefit on any third party that is not a signatory to this Agreement.
- 4.19 Legal Actions. In addition to any other rights or remedies, and subject to the mediation requirements in Section 4.13, and further subject to the notice and right to cure provisions in Section 4.12, any Party may institute legal action against a defaulting Party or a defaulting Parcel Owner to cure, correct, or remedy any default or breach, to specifically enforce any covenants or agreements set forth in the Agreement or to enjoin any threatened or attempted violation of the Agreement, or to obtain any remedies consistent with the purposes of the Agreement. Legal actions shall be instituted in the Superior Court of the County of Orange, State of North Carolina, and the Participating Parties hereto submit to the personal jurisdiction of such court without application of any conflicts of law's provisions of any jurisdiction. In the event that it becomes necessary for a Participant to pursue a civil action against a defaulting Participant, the prevailing party in such action shall be entitled to recover its reasonable attorney fees and costs from the defaulting party if such fees are awarded by a court of competent jurisdiction.
- 4.20 Notices. Unless specifically provided otherwise by this Agreement, any notice, demand, request, consent, approval or communication which a signatory Party is required to or may give to another signatory Party hereunder shall be in writing and shall be delivered or addressed to the other at the address below set forth or to such other address as such Party may from time to time direct by written notice given in the manner herein prescribed. Such notice or communication shall be deemed to have been given or made when communicated by personal delivery or by independent courier service or by facsimile or by email with a hard copy to be delivered by independent courier service by the next business day. The Parties shall make reasonable inquiry to determine whether the names or titles of the persons listed in this Agreement should be substituted with the name of the listed person's successor. Notice to a Parcel Owner shall be to the address designated in the deed conveying the Parcel to the Parcel Owner.

All notices, demands, requests, consents, approvals or communications to the Town of Chapel Hill shall be addressed to:

Planning and Development Services
Town of Chapel Hill
405 Martin Luther King, Jr. Blvd. Chapel Hill, NC 27514
919-969-5066 (phone)
planning@townofchapelhill.org (email)

All notices, demands, requests, consents, approvals or communications to the Parties shall be addressed to:

Property Office
University of North Carolina at Chapel Hill
103 Airport Drive, CB #1060
Chapel Hill, NC 27599-1060
919-966-3297 (fax)
property@unc.edu (email)

Town Manager
Town of Chapel Hill
405 Martin Luther King, Jr. Blvd. Chapel Hill, NC 27514
919-969-2063 (fax)
manager@townofchapelhill.org (email)

- 4.21 Entire Agreement. This Agreement sets forth and incorporates by reference all of the agreements, conditions and understandings between the Parties relative to the Property and supersedes all previous agreements. There are no promises, agreements, conditions or understandings, oral or written, expressed or implied, among the Parties relative to the matters addressed herein other than as set forth or as referred to in this Agreement or as contained in the LUMO as of the Effective Date.
- 4.22 Construction. The Parties agree that each Party and its counsel have reviewed and revised this Agreement and that any rule of construction to the effect that ambiguities are to be resolved against the drafting Party shall not apply in the interpretation of this Agreement or any amendments or exhibits hereto.
- 4.23 Assignment. After notice to the Town and to the Municipality, the University may assign its respective rights and responsibilities hereunder to subsequent land owners of all or any portion of the relevant parcels of land, provided that no assignment as to a portion of the relevant parcel of land will relieve the assigning Party of responsibility with respect to the remaining portion of the relevant parcel of land owned by the assigning Party without the written consent of the Town.
- 4.24 Governing Law. This Agreement shall be governed by the laws of the State of North Carolina.
- 4.25 Counterparts. This Agreement may be executed in several counterparts, each of which shall be deemed an original and such counterparts shall constitute one and the same instrument.
- 4.26 Agreement to Cooperate. In the event of any legal action instituted by a third party or other governmental entity or official challenging the validity of any provision of this Agreement, the Participating Parties hereby agree to cooperate in defending such action; provided, however, each Participant shall retain the right to pursue its own independent legal defense.
- 4.27 Termination. This Agreement shall terminate within 20 years of the recording of this agreement, unless both parties agree to an extension; or a specific termination made by operation of the provisions of this Agreement; or by agreement of the Parties. Any Termination other than by expiration of the term shall be recorded in the Registry. Termination of this Agreement shall not affect any of the following:
- a) any requirements to comply with the applicable terms and conditions of the LUMO, Site Development Permits, approval and acceptance of infrastructure improvements, and any applicable permits;

- b) rights under this Agreement with respect to which a Site Development Permit has been issued by the Town Manager prior to the termination or expiration but for which construction is not completed.
- c) In the event consideration is given to (i) suspension of this Agreement or (ii) termination of this Agreement, the Parties agree that each will identify appropriate representatives to meet and participate in good faith negotiations and mediation as provided in Section 4.13, aimed at resolving the issues prompting that consideration.

4.28 No Obligation to Develop. It is understood that the Town's and University's development of the Project depends upon a number of factors including, but not limited to, the availability of financing, state appropriations, receipt funds, general economic factors, and academic and programmatic needs. Nothing in this Agreement shall be construed as requiring the Town or University to develop the subject property and any failure to develop the subject property shall not be deemed a default by the Town or University of its obligations set forth in this agreement.

4.29 No Deemed Waiver. Failure of a Party to exercise any right under this Agreement shall not be deemed a waiver of any such right and shall not affect the right of such Party to exercise at some future time said right or any other right it may have hereunder.

4.30 Severability. If any term or provision herein shall be judicially determined to be void or of no effect, such determination shall not affect the validity of the remaining terms and provisions. The participating Parties agree that if any provision of this Agreement is judicially determined to be invalid because it is inconsistent with a provision of state or federal law, this Agreement shall be amended to the extent necessary to make it consistent with state or federal law and the balance of the Agreement shall remain in full force and effect. Participating parties, having voluntarily agreed to be contractually bound, for themselves and their successors and assigns, accept all of the terms of the Agreement and confirm their belief that the terms are consistent with applicable law as of the Effective Date.

4.31 Authority. Each Party represents that it has undertaken all actions necessary for approval of this Agreement, and that the person signing this Agreement has the authority to bind the Parties on behalf of whom they have executed this Agreement.

4.32 Transparency and Public Involvement. It is the intent of the participating Parties that all aspects of the implementation of this Agreement shall be carried out in an open, transparent fashion with opportunities for effective and meaningful public involvement. The Town and the University shall take reasonable steps to make information about all aspects of the implementation of this Agreement (including required studies, analysis, plans, reports, and applications which are public record) fully available for public review with the exception of any attorney-client privileged information, financing documentation, market analysis, internal financial documentation, reports, pro formas, returns or other personal information.

The Developers shall take efforts to form a committee consisting of interested residents, Town, and University staff to allow for future dialogue before and during construction efforts. Adjacent residents shall be notified of upcoming construction, in accordance with 5.22, and the Town and the University shall take reasonable steps to form a committee to discuss construction issues during periods of construction. The matters of such a committee may be continued during operations of the site.

4.33 Estoppel. Each of the participating Parties agree, from time to time, within twenty (20) days after

request of the other Participant, to deliver to the requesting Participant or such Participant's designee, an estoppel certificate stating that this Agreement is in full force and effect, the unexpired term of this Agreement, and whether or not, to such Participant's knowledge, there are any existing defaults or matters which, with the passage of time, would become defaults under this Agreement. It is understood and agreed that the Parties' obligation to furnish such estoppel certificates in a timely fashion is a material inducement for the other's execution of this Agreement. In no event may any Party request from the other an estoppel certificate more than one (1) time in any twelve month period other than in connection with a bona fide sale or financing of the Property or portion thereof, any interests in, or any assets of, any Party.

ARTICLE 5: SPECIFIC STANDARDS AND MITIGATION MEASURES

The Parties do hereby agree to the specific standards and mitigation measures set forth in this Section.

5.1 Scale of Development and Uses Permitted.

- a) The development of the Property shall not exceed the limits in Table 1 of this Article and shall be generally consistent with the layout in EXHIBIT A. A design is generally consistent if it does not significantly change the appearance, function, or impact of the project to the detriment of neighboring properties or the community.

Table 1: Scale of Development

Land Area	Total Floor Area	Maximum Building Height	Maximum Number of Parking Spaces
20.55 acres	200,000 s.f.	4 stories	615 spaces

- b) Land uses within the University-1 (U-1) zoning district and as further modified in EXHIBIT F are permitted.
- c) The Town may build and/or occupy a maximum of 100,000 s.f. of the allowable 200,000 s.f. of building area on the Property.
- d) The property is designed such that buildings and infrastructure are located towards Estes Drive and away from the Elkin Hills neighborhood.

5.2 Timing of Development

- a) Development of individual buildings is anticipated to occur in separate phases through the Term of the agreement.
- b) A Site Development Permit is required for each building.
- c) The following land uses and activities that do not involve the construction or use of a building shall be undertaken in a manner substantially consistent with the terms of this Agreement. and the Town and University shall include a report of all such activities undertaken in the previous year in the Annual Report required by this Agreement:
 - i. Maintenance and improvements to existing utility lines;
 - ii. Stormwater lines and improvements;
 - iii. Stormwater structures;
 - iv. Public utility lines traversing site (Duke Energy, PSNC, UNC, etc.);
 - v. Utility structures without a building (e.g., transformers);
 - vi. Alterations to utility equipment (generator, other mechanical components);
 - vii. Site storage and construction staging areas;
 - viii. Stream restoration projects;
 - ix. Greenways and other trails;
 - x. Public art.

5.3 Phasing

- a) First Phase: The Municipal Services Center is anticipated to be the first phase of development as generally illustrated in EXHIBIT B. Land disturbance shall be limited to the extent possible to allow earthwork where necessary for development of the building and supporting infrastructure in EXHIBIT C. The first phase shall include construction of the Municipal Services Center with ancillary infrastructure serving the building and the following improvements:
 - i. Construction of an internal access road with two points of access on Estes Drive.

- ii. Stormwater Control Measures, as specified in the Stormwater Management Report, to treat stormwater for the entire Project Area.
 - iii. Vegetative planting to provide screening and buffering of the first phase of development, and planting of additional buffer areas that would not be negatively impacted by future phases of construction.
 - iv. Vehicular and bicycle parking to serve the Municipal Services Center.
 - v. Documentation of SEPA compliance (Environmental Assessment and either Finding of No Significant Impact or Environmental Impact Study) is required for the entire plan of development.
- b) Subsequent Phases: Every building constructed after the Municipal Services Center is expected to provide its own screening, infrastructure, utilities, and parking.
- i. Each phase of subsequent development constructed by either the University or the Town shall provide infrastructure associated with building development and vegetative planting to screen the proposed use from residential properties located to the south and east.

5.4 Open Space and Natural Areas

- a) A minimum 100 foot buffer along the southern and eastern boundary of the property shall remain undisturbed except for the minimum disturbance required to install a sanitary sewer connection to Hartig Street and walking paths as generally shown on conceptual site plan. The following may be permitted within the buffer area:
- i. Planting of new vegetation on the interior side of the buffer.
 - ii. Walking trails
 - iii. Forest education or other passive use of the wooded area that does not cause audial, visual, or other nuisance.
- b) A minimum 50 foot buffer shall be provided surrounding all intermittent streams which may be encroached only to allow road and infrastructure crossings. Encroachments shall be designed and constructed to have the minimum necessary impact on the buffer.

5.5 Stormwater Management

- a) Stormwater management shall be integrated into the site, building, and landscape design, with stormwater management strategies coordinated and applied in a comprehensive manner across the entire Project. The intent of this section is to improve stormwater conditions after development.
- b) Stormwater Control Measures calculated to treat the maximum impervious surface of the entire Property shall be submitted with the initial Site Development Permit application.
- c) EXHIBIT A shows the general location of impervious surfaces in the Development.
- d) Prior to issuance of the first Site Development Permit, the Applicant must submit a Stormwater Management Plan for the project which clearly identifies the stormwater impacts associated with the proposed development and clearly documents how those stormwater impacts are proposed to be mitigated by the improvements proposed in the application. Stormwater Management Plans shall clearly demonstrate compliance with the design criteria specified in this Agreement, applicable NCDEQ permit requirement, and applicable University, Federal, and State rules.
- e) Each Site Development Permit application shall provide a tabulation of the proposed and total impervious surface to demonstrate compliance with the impervious surface permitted by the Stormwater Management Plan.
- f) Peak Discharge Rate Limits: The post-development stormwater runoff peak discharge rate shall be controlled such that the post-development runoff peak discharge rate at all locations where stormwater runoff exits in the Project (or at other points designated in the conceptual plan), shall not exceed the stormwater runoff peak discharge rate for the local 1-year (2.88 inches), 2-year

- (3.60 inches), and 25-year (6.41 inches), and 50-year (6.86 inches) 24-hour duration storm events.
- g) Two- (2-) Year Volume Control: At each location where the stormwater exits the Project, the difference in the runoff volume generated by 2- year (3.60 inches) frequency, 24-hour duration storm event in the post-development conditions and runoff volume generated by the same storm event in the pre-development conditions shall be managed on-site and released over a period of 2 days to 5 days.
 - h) Eighty-five percent (85%) Total Suspended Solids (TSS) Removal: All post-development stormwater runoff resulting from the first one inch of precipitation shall be treated to remove 85% of total suspended solids of all new impervious surfaces resulting from development of the entire Property. Stormwater treatment facilities will be designed according to the North Carolina Department of Environmental Quality (NCDEQ) Stormwater Best Management Practices Manual as modified by the Town of Chapel Hill; the Town of Chapel Hill Design Manual, as amended; and any future written design guidance approved by both the Town and NCDEQ.
 - i) Upon completion of each Site Development Permit, the Municipality shall receive:
 - i. The maintenance access must be shown and/or described in the Stormwater Plans. A copy of the Operations and Maintenance Plan, signed by the owner and for the stormwater management facility(ies). The Operations and Maintenance Plan must include a description of the device or structure, an inspections checklist, and operating and maintenance procedures. The plan should identify contact information, who will perform the inspections, frequency of inspections, inspections and maintenance logs, any specific equipment needs or certifications (e.g., confined space certification), action levels or thresholds (e.g., remove sediment after depth exceeds one foot), and disposal methods.
 - ii. Certified as-built plans, signed and sealed by a North Carolina-registered Professional Land Surveyor, showing building footprints, driveways, all other impervious surfaces, stormwater drainage/conveyance piping, and stormwater management structures. The as-built plans should be in DXF binary format using State plane coordinates and NAVD 88.
 - iii. Certification, signed and sealed by a North Carolina-registered Professional Engineer, that the stormwater management facility(ies) was/were constructed in accordance with the approved plans and specifications.
 - j) Proposed covered parking/underground parking areas will require oil/water separator in the parking deck to collect the runoff prior to discharge into the sanitary sewer. The top level of parking areas will drain to the proposed stormwater control measures.
 - k) The sumps of hydraulic elevators, if proposed, shall be connected to the sanitary sewer.
 - l) The development shall meet the Jordan Lake Rules in place at the time of approval of the Development Agreement. Per Jordan Watershed Stormwater Management for Development, Nitrogen and Phosphorus exported from the Property shall not exceed 2.2 pounds/acre/year and 0.82 pounds/acre/year respectively.
 - m) That Stormwater runoff from the site shall be reused whenever possible.
 - n) Stormwater control measures shall not be permitted within the 100 foot vegetated buffer.
 - o) Once project funding is allocated, the Town shall initiate an evaluation of downstream stormwater conditions and opportunities for improvement. The evaluation will include documentation of pre-construction stormwater conditions, and downstream stormwater performance shall be monitored following construction of the Municipal Services Center.

5.6 Stream Buffers

- a) Development shall be consistent with the Resource Conservation District regulations of the Town applicable as of the date of this Agreement. All activities designated as permitted uses or special

uses in Table 3.6.3-2 of the LUMO that are consistent with this Agreement shall be designed in compliance with this Section.

- b) The Town or University may perform and use a stream determination for future development provided that the location of buildings and infrastructure is consistent with EXHIBIT A.
- c) Development shall comply with Sections 404 and 401 of the Clean Water Act and with the Jordan Buffer Rules. As the landowner of record, the University shall review and provide comments to the Town on all 404, 401 and Buffer Authorization permits prior to their submittal to the applicable regulatory agencies.

5.7 Tree Canopy & Landscaping:

- a) A minimum of 40 percent tree canopy shall be maintained.
- b) Native plant species shall be used by the Town in all plantings. Prior to the issuance of the first Site Development Permit, the Project shall consult with Town staff, the North Carolina Botanical Garden, and other resources for appropriate species.
- c) Invasive species shall not be allowed.
- d) The Project shall be planned to support a low maintenance, low water use, low fertilizer use landscape with 'best suited' plant materials.
- e) Landscape Protection plans and Planting Plans for individual Site Development Permit applications shall identify existing and proposed tree canopy mix and percent coverage, and landscape materials. If irrigation is proposed, controls shall utilize smart technology to conserve water. Until such time as the University occupies the Property, the Town shall contact UNC Grounds to consult on all landscape design, protection, and planting plans prior to implementation.
- f) Continuous tree protection fencing shall be shown at the limits of disturbance on the demolition and grading plans. Fencing must be installed and inspected prior to any site work or clearing.
- g) A foundation buffer strip, as described in LUMO 5.9.5.c.2, may be provided in variable width.

5.8 Compatibility and Buffers:

- a) Development shall strive to be compatible with existing adjacent development and will be buffered per LUMO 5.4. Development near existing neighborhoods shall respect buffers, height limits, lighting, drainage, noise impacts.
- b) A planting mix or density is not prescribed for the southern or eastern buffer. Existing vegetation will be undisturbed but supplemental plantings may be placed adjacent to the buffer to improve screening as practical.
- c) A landscape buffer as described in the Town Design Manual is not required along Estes Drive.
- d) Noise and Lighting impacts will be regulated per Sections 5.17 and 5.18 in this agreement.

5.9 Transportation: General Improvements, Traffic Impact Study, Specific Improvements, Transit, Parking, Streets, Sidewalks, Bikeways, and Greenways

The general location of transportation-related improvements is shown in EXHIBITS E and K.

- a) General Provisions:
 - i. EXHIBIT E provides a plan for vehicle, bicycle, pedestrian, and bus amenities on the site. The exact location of each improvement shall be illustrated in each Site Development Permit, and be consistent with the locations shown on EXHIBIT E.
 - ii. The internal access road with two accesses on Estes Drive is designed to contain development in the northern portion of the site and be located away from residential properties to the south and east. Final design of the road shall reflect this consideration.

- iii. The location of bicycle, pedestrian, and bus amenities should be coordinated with the Carolina North Development Agreement (including planning for the campus to campus connector), and Town master plans for bikes and greenways.
- b) Traffic Impact Study:
 - i. The Municipality’s consultant performed a Traffic Impact Study for the first phase of development, the Municipal Services Center. Impacts associated with that building were studied and determined for this agreement and are listed in 5.9.c and 5.9.d. The Traffic Impact Study is provided as EXHIBIT K.
 - ii. An internal access road with two accesses on Estes Drive shall be constructed with the Municipal Services Center Phase as shown on (EXHIBIT E).
 - iii. A Traffic Impact Study will be performed for each subsequent Site Development Permit that results in an increase of daily trip generation of greater than 500 trips, or 250 vehicles per day, whichever is less.
 - iv. The applicant for a future Site Development Permit shall pay the cost of a required Transportation Impact Study and any necessary improvements within the site or right of way.
- c) Necessary Improvements - Due to Site Impact
Construction of the Municipal Services Center shall include these specific improvements:
 - i. Widen Estes Drive along the length of site frontage to provide a consistent three-lane cross-section with exclusive westbound left-turn lanes into the site at the two proposed site driveway intersections. This improvement improves operations for stop-controlled movements at both intersections and improves overall safety by removing the left-turn movements from the through traffic streams along the Estes Drive.
 - ii. Provide a bus stop and amenities for transit riders along the frontage of the proposed Municipal Services Campus.
- d) Necessary Improvements – Regardless of Site Impact
 - i. The applicant shall widen Estes Drive to provide exclusive westbound left-turn lanes into the site at the two proposed site driveway intersections. These (dedicated turn lanes) improve operations for stop-controlled movements at both intersections and improves overall safety by removing the left-turn movements from the through traffic streams along the Estes Drive corridor.
- e) General Coordination for Estes Drive Corridor:
 - i. The Town shall construct the improvements related to the project and coordinate with future NCDOT, Town, or University-funded projects to widen Estes Drive between the proposed site frontage and the NC Highway 86 (Martin Luther King Jr. Blvd.) intersection to a consistent three-lane cross-section. These improvements shall be compatible with the design of the NCDOT pedestrian and bicycle improvement project along the Estes Drive corridor.
 - ii. Estes Drive shall be improved along the property frontage to provide a separated bike lane and a multi-use or pedestrian facility, subject to review by the Town Manager.
 - iii. The applicant shall coordinate with NCDOT to install a pedestrian crossing across Estes Drive between the Property and the UNC Park & Ride. The pedestrian crossing shall utilize Rectangular Rapid Flash Beacons (RRFB), illumination, or other enhanced features to improve pedestrian safety.

- f) Roadway Improvements for future Site Development Permits:
 - i. Each Site Development Permit will include information about the phasing of the appropriate connections and infrastructure to support occupancy of each building.
 - ii. When Carolina North is developed, the Town shall coordinate with NCDOT to evaluate installation of a pedestrian crossing across Estes Drive at the eastern driveway.

- g) Vehicular Parking:
 - i. A maximum of 615 parking spaces shall be permitted on the Property. An increase shall constitute a major modification.
 - ii. A maximum vehicular parking ratio of 3.5 spaces per 1,000 square feet of building area shall be permitted, excluding supplemental parking for police vehicles.
 - iii. Individual Site Development Permit applications shall demonstrate an adequate amount of vehicle parking for the proposed use, including handicapped and visitor spaces.
 - iv. The applicant shall provide the minimum required handicapped parking spaces and design all handicapped parking spaces, ramps, and crosswalks, and associated infrastructure according to Americans with Disabilities Act standards, North Carolina Building Code, American National Standards Institute (ANSI) Code, and Town standard.
 - v. Prior to issuance of a Certificate of Occupancy, the Applicant shall construct the proposed surface parking lot to Town standard for dimensions and pavement design and the Applicant shall construct the proposed parking deck to National Parking Association standards or to another nationally accepted standard that may be approved by the Town Manager.
 - vi. A shared parking model may be provided with each Site Development Permit application.
 - vii. A minimum of twenty (20) percent of the parking spaces approved under each Site Development Permit shall be built with conduit to allow for future electric vehicle charging.
 - a) At least 1 percent, or a minimum of five parking spaces, shall be DC Fast Charge capable.

- h) Bicycle Parking:
 - i. The Town shall comply with LUMO bicycle parking requirements for a *public use facility*, and shall provide a mixture of Class I and Class II bicycle parking per the Engineering Design Manual.
 - ii. Bicycle parking will be located close to building entrances to allow riders easy ingress and egress. If sheltered bicycle parking is provided within the parking garage it shall be located near the building entrance.
 - iii. The University will comply with University standards for required amounts, locations, and types of bicycle parking.
 - iv. Prior to the issuance of a Site Development Permit, the Applicant shall provide the Town with an agreed upon bicycle parking plan for the Project that addresses the quantity and locations of bicycle parking for the site.

- i) Transit
 - i. A bus shelter on Estes Drive shall be constructed with the first Site Development Permit. The shelter shall contain solar lighting, and next bus information. A bus pull-off shall not

- ii. Sidewalks shall connect the bus shelter to the Municipal Services Center.
- j) Transportation Management Plan
 - i. A Transportation Management Plan (TMP) shall be submitted or updated with each Site Development Permit application. Each building is encouraged to have its own TMP Champion. The TMP shall contain the checklist items as of the Effective Date, and an annual report shall be submitted to the Town.
- k) Relationship to Carolina North improvements
 - i. During each Site Development Permit review, the Town will consider whether any improvements have been constructed in satisfaction of the Carolina North Development Agreement and whether they offset the need for separate improvements on this site. A traffic impact study considering current conditions and expected growth at the time of Site Development Permit application shall be the basis for this evaluation.
- l) Greenway:
 - i. The applicant shall construct a ten foot minimum width multimodal greenway connection to Hartig Street. The greenway shall consist of a non-paved surface.
 - ii. A greenway shall be coordinated with the Carolina North Development Agreement campus to campus connector and constructed along the property frontage and to Hartig Street in general conformance with the location shown on the general site layout plan.
 - iii. The site greenway shall be constructed with the first phase of development.
 - iv. The site greenway shall be constructed to American with Disabilities Act (ADA) standards.
 - v. All pedestrian, bicycle, and greenway facilities within the Property shall be designed and constructed to meet Town standards unless otherwise approved by the Town Manager.
- m) Sidewalks:
 - i. Sidewalks shall be provided within the Project to provide connectivity between buildings, parking lots, the greenway connection, pedestrian facilities along the street frontage, transit stop, and other site amenities.
 - ii. Sidewalks shall be six feet in width, and this width may be reduced to five feet to preserve or plant adjacent trees.

5.10 Energy:

- a) Town buildings, including the Municipal Services Center, shall achieve LEED Silver certification, at a minimum.
- b) The Developers will include energy-efficient building practices and sustainable building practices in the design and construction of individual buildings and the Project as a whole.
- c) An Energy Management Plan shall be submitted with each Site Development Permit. The plan shall:
 - i. consider utilizing sustainable energy, currently defined as solar, wind, biofuels, and hydroelectric power;
 - ii. consider purchase of carbon offset credits and green power production through coordination with the NC Green Power program;
 - iii. provide for 20 percent more efficiency than the latest applicable standard for ASHRAE (e.g., 90.1) that ensures indoor air quality and adequate access to natural lighting, and

- iv. allows for the proposed utilization of sustainable energy in the project;
- v. include on-going energy management practices, and
- v. require that the property owner reports to the Town of Chapel Hill both the expected energy consumption as part of a model prior to issuance of a Site Development Permit and the actual energy consumption as compared to sealed engineering calculations at the time construction is completed.
- d) The goals of the Environmental Stewardship Advisory Board Development Review (provided as EXHIBIT N) shall be considered with each Site Development Permit application.
- e) Graywater use for reclamation and irrigation is encouraged.
- f) All building roofs shall be designed as to be “solar ready” to accommodate future photovoltaic systems unless use of another green building feature such as a green roof, presents a conflict.
- g) For a Site Development Permit that includes a parking structure, the applicant will explore the feasibility of applications to reduce the heat island and increase albedo (reflected sunlight) of the parking garage.

5.11 Design Standards

- a) Prior to Town Staff approval of a Site Development Permit, the applicant shall present final building elevations to the Community Design Commission for review and comment.
- b) The final location and design of buildings shall be reviewed by UNC Chapel Hill staff and be subject to all necessary University approvals required for University or State-owned land.
- c) Should the applicant choose to install public art, the application will present the public art to the Cultural Arts Commission and the appropriate University entity for their review and comment.

5.12 Utilities

- a) A sanitary sewer connection along with the dedication of a sewer easement shall be permitted to Hartig Street.
- b) The University may provide utilities to University-owned buildings on the Property.
- c) The Town will be responsible for securing utilities for Town-owned buildings on the Property.

5.13 Emergency Services

- a) The Town shall be responsible for its own police, fire, and emergency medical services until the University elects to exercise its option to occupy its allocated portion of the Property. If the University occupies a portion of the Property, the Town and University shall arrange for emergency services under the generally applicable arrangements for jurisdiction and operations on University-owned property. In general, for University-owned and occupied property, the University provides police services, the Town provides fire services, and Orange County provides most emergency medical services. This Agreement shall not be deemed to restrict changes in these jurisdictional arrangements as may from time to time be mutually agreed to by the service providers.
- b) The site plan as shown in EXHIBIT A includes the location for a future fire station. Review and approval of any additional conditions associated with that future use shall require a major modification of the Development Agreement at the time a station is needed.

5.14 Historic and Cultural Features

- a) An archaeological study was performed and no significant features were found. No further archaeological study is required with Site Development Permit submittals.

5.15 Construction Waste Management

- a) Construction waste shall be managed in accordance with Town standards and with the Orange County Regulated Materials Ordinance.

5.16 Solid Waste Management.

- a) Construction waste shall be managed in accordance with Town standards and with the Orange County Regulated Materials Ordinance.
- b) Each individual Site Development Permit shall provide clear direction on who will provide solid waste service for each building and each building will be designed for private waste collection.
- c) Prior to the issuance of each Site Development Permit, the Applicant will provide a Will-Serve letter for solid waste and recycling collection.

5.17 Noise/Communication During Construction

- a) The Town's Noise Ordinance shall apply to the Development during construction and occupancy of the Property.
- b) Buildings shall be designed to minimize noise impacts on adjacent properties from equipment, infrastructure, vehicles, and daily operations on the Property.
- c) Noise during construction:
 - vi. As provided in Section 4.8, prior to issuance of a Site Development Permit the Applicant shall include a construction management plan that provides the following noise-mitigation information at a minimum:
 - a) Indicate how the project construction will comply with the Town's Noise Ordinance; and
 - b) Provide a phone number for noise notifications during the construction period.
- d) A construction sign to facilitate communication during the project and containing a phone number to report noise issues shall be located in the Elkin Hills neighborhood. The sign shall be located in a visible location within the right of way, such as a median. The exact location of the sign shall be determined through consultation between interested neighbors and Town staff.
- e) The Applicant will communicate directly with the neighborhood through electronic media, mailings, or face-to-face meeting to provide construction contact information for the duration of the construction of any work associated with a Site Development Permit.
- f) Complaints regarding compliance with the noise ordinance during construction shall be handled by the Town for Town projects, and by the University for University projects.

5.18 Lighting

- a) The project shall provide sensitive lighting design that does not intrude on adjacent properties.
- b) Each individual Site Development Permit application shall describe all proposed lighting and demonstrate no increase in lighting foot-candle levels at the adjacent property line through submittal of a photometric plan.
- c) Site lighting shall be energy efficient and appropriate for the program requirements and times of use.
- d) All Town lighting standards in effect as of the Effective Date of this Agreement shall apply to the Project, including the Municipal Services Center. Future buildings shall meet or exceed those same standards.
- e) New lighting within the Development shall comply with the following:
 - i. All lighting, including that used in and around buildings, parking areas, walkways, roadways, and signs, shall be designed to minimize spillover light onto property adjacent to the Property.
 - ii. All lighting shall be designed to prevent glare that could impair vision and/or otherwise deteriorate normally accepted qualities and uses of property adjacent to the Property.
 - iii. Outdoor lighting shall be mounted at heights no greater than fifteen (15) feet for non-cutoff

lights and no greater than thirty-five (35) feet for most cutoff lights.

- f) Photocell or motion sensor-activated, or other energy efficient light fixtures shall be utilized across the site except as counter-indicated for police or emergency services.
- g) Light Emitting Diode (LED) bulbs are preferred for both interior and exterior lighting.

5.19 Signs

- a) Signs shall be permitted in accordance with LUMO 5.14.

5.20 Sedimentation:

- a) Erosion and Sediment Control: Construction at the Property shall comply with applicable soil and erosion control regulations of North Carolina Department of Environmental Quality.
- b) The Town shall comply with all applicable University, State, and local soil and erosion control regulations, and shall be responsible for implementing erosion and sedimentation control measures for all land disturbing projects.
- c) The Town agrees to comply with the University's Erosion and Sedimentation Control Permit Application Process for development located on University Property (see attached process chart). As landowner of record, the University must approve of the Erosion and Sedimentation Control Plan prior to its submittal to the State for review.
- d) Discharge of dewatered water from excavated areas and erosion control basins will require approval of Stormwater Management Division of the water quality prior to pumping into storm sewer pipes.
- e) The Town shall provide erosion control measures for the 25-year storm during construction.

5.21 Construction Management Plan:

- a) The Developer shall provide a Construction Management Plan prior to issuance of a Site Development Permit. The plan shall provide for construction employee parking, construction vehicle access and routes, the location of any construction office, materials staging areas, and hours of work.
- b) The Developer shall provide a Traffic Control Plan prior to issuance of a Site Development Permit. The plan shall include, at a minimum, detour and signage for pedestrian, bicycle, and vehicular traffic during construction.

5.22 Public Notification and Participation

- a) The Developer shall conduct a meeting with opportunity for citizen participation and attendance by a Town staff representative; for the purpose of discussing possible design features of new facilities prior to submission of each individual site development permit application. The University shall distribute notice of the meeting to all property owners within 1,000 feet of the Property.
- b) This notice shall specify the date, time, location and purpose of the meeting. This notice shall be mailed or otherwise distributed no later than one month prior to the meeting. Minutes of the meeting and the meeting attendance list shall be made publicly available before presentation of individual site development permit applications to the Town for approval. The public meeting shall provide an opportunity to discuss the presence of outdoor activities, if any are held, and whether mitigations are needed.
- c) Town and University staff shall be identified to serve as a liaison to interested residents before and during construction efforts.
- d) Prior to submittal of the first Site Development Permit, the Town shall contact adjacent residents to form a committee consisting of residents and Town staff to allow dialogue before and during construction efforts.

5.23 Duty to Comply with Regulations and Mitigate Environmental Releases

- a) The Town will immediately clean up any environmental releases on University-owned property that result from the Town's operations.
- b) In event of a clean-up, the Town will comply with all Federal and State regulations for cleanup, environmental investigation and remediation of all chemical releases to the environment.
- c) The Town will be responsible for all costs associated with clean up, investigation and remediation of chemical releases from Town operations.
- d) All clean up, investigative and remediation documentation and site work on University-owned land shall be reviewed by University staff.
- e) The University will be responsible for immediately addressing any environmental releases that result from their operations on the property and shall comply with all Federal and State regulations.
- f) The Town shall not place any deed restrictions on the University's property.
- g) Chemicals (including fuel) shall not be stored in underground storage tanks on the Property.
- h) The Town is responsible for any fines and penalties associated with Town operations on the University's property.

5.24 Fiscal Impact

- a) Prior to submission of a University-initiated Site Development Permit, the two agencies shall draft a mutually acceptable Memorandum of Understanding or similar guidance for the following:
 - i. Joint and/or individual responsibilities for landscape maintenance
 - ii. Joint and/or individual responsibilities for infrastructure maintenance including but not limited to sidewalks, roadways, stormwater management facilities, parking areas, bicycle facilities, and greenways.
 - iii. A system for tracking costs for future-shared infrastructure (such as parking, roadways and stormwater facilities) so that the cost of full infrastructure for the Project can be shared in a pro-rata manner as each party builds structures and infrastructure on the Property.
 - a) Shared infrastructure shall include the following:
 - i. all stormwater management facilities
 - ii. the drive aisle that serves each of the buildings
 - iii. sidewalks along the drive aisle that serves each of the buildings
 - iv. greenway
 - v. sanitary sewer connection to Hartig
 - vi. transit shelter
 - vii. cost of Estes Drive improvements
 - viii. lighting
- b) The costs for each of the above improvements shall be itemized and documented by the Town following the first Site Development Permit. Alternately, the above topics may be addressed in a lease document between the Town and the University.
- c) Subject to the terms and conditions of this Agreement, the Town of Chapel Hill shall be wholly responsible for all property and infrastructure maintenance (and associated costs) while it is the sole occupant of the site.
- d) The Town of Chapel Hill shall be responsible for property and infrastructure maintenance while it is the sole user of the site.

5.25 Annual Report

- a) The Applicants shall submit to the Town Manager an Annual Report that includes the information required by this Agreement and that provides all necessary information for the Town Manager to assess their good faith compliance with the terms of this Agreement. This report shall form the

basis for the Town Manager's periodic review of the Agreement as required by G.S. 160A-400.27(a). This required report is generally referred to as the "Annual Report."

- b) The initial Annual Report shall be filed on or before September 1, 2019 and shall report on activities from July 1, 2018 through June 30, 2019. Subsequent reports shall be filed on or before September 1 each year and shall report on activities in the preceding fiscal year (the preceding reporting period).
 - i. The Annual Report shall include the specified items set forth in this Agreement and listed in this Section. The failure to include in this Section an item expressly required to be included by other Sections of this Agreement shall not relieve the Applicants of the responsibility to include that item in the Annual Report. The report may include such other items as deemed relevant by the Applicant. The Town Manager may also request inclusion of other specific information or provide for its inclusion in the following year's Annual Report if such requested information reasonably relates to Development.

EXHIBIT A

SITE PLAN

- A** MUNICIPAL SERVICES BUILDING
72,000 SQ. FT. X 3.5 FLOORS
 - B** TOWN EXPANSION BUILDING
28,000 SQ. FT. X 3.5 FLOORS
 - C** UNIVERSITY BUILDING
100,000 SQ. FT. X 3.5 FLOORS
 - SP** STRUCTURED PARKING
 - S** SURFACE PARKING
 - SCM** STORM WATER CONTROL MEASURE
BIORETENTION CELL
- INTERMITTENT STREAM CENTERLINE
- - - 50 FT. STREAM BUFFER



NOT TO SCALE - FOR REFERENCE ONLY



EXHIBIT A - ALT

SITE PLAN

- A** MUNICIPAL SERVICES BUILDING
72,000 SQ. FT. X 3.5 FLOORS
- B** TOWN EXPANSION BUILDING
28,000 SQ. FT. X 3.5 FLOORS
- C** UNIVERSITY BUILDING
100,000 SQ. FT. X 3.5 FLOORS
- SP** STRUCTURED PARKING
- S** SURFACE PARKING
- SCM** STORM WATER CONTROL MEASURE
BIORETENTION CELL
-  INTERMITTENT STREAM CENTERLINE
-  50 FT. STREAM BUFFER
-  POTENTIAL FIRE STATION



NOT TO SCALE - FOR REFERENCE ONLY



EXHIBIT B

SITE PLAN - PHASE ONE

- A** MUNICIPAL SERVICES BUILDING
72,000 SQ. FT. X 3.5 FLOORS
- SP** SURFACE PARKING
290 SPACES PROVIDED
- SCM** STORM WATER CONTROL MEASURE
BIORETENTION CELL
- INTERMITTENT STREAM CENTERLINE
- - -** 50 FT. STREAM BUFFER



NOT TO SCALE - FOR REFERENCE ONLY

EXHIBIT C

CLEARING LIMITS - PHASE ONE

--- CLEARING BOUNDARY

/// CLEARING AREA



NOT TO SCALE - FOR REFERENCE ONLY

EXHIBIT D

BUFFERING AND LANDSCAPING - PHASE ONE

B BUFFER OPPORTUNITY
BERMING AND PLANTING





L LANDSCAPING OPPORTUNITY



NOT TO SCALE - FOR REFERENCE ONLY

EXHIBIT E

SIDEWALKS AND PATHS - PHASE ONE

-  SIDEWALK/MULTI-MODAL PATH
-  BUS STOP WITH ACCESSIBLE ROUTE
-  INTERNAL SIDEWALK (CONNECTION TO ESTES DRIVE)
-  PATHWAY CONNECTION (HARTIG ST.)
-  INTERNAL PEDESTRIAN CIRCULATION



NOT TO SCALE - FOR REFERENCE ONLY

Exhibit F: Permitted Land Uses

Permitted Use	Permitted, Accessory
Accessory use customarily incidental to a permitted principal or special use	A
Automated teller machines (ATM) (Walkup)	P
Clinic	P, A
College or University	P
Essential services	P, A
Public cultural facility	P, A
Public use facility	P, A
Radio, television or wireless transmitting and/or receiving antenna, accessory	A
Research Activities, Light	P
Temporary portable building: Construction-related (See also Article 6)	A

Exhibit G - Legal Description

Legal Description: Former Dixon Property

Beginning at an iron pipe located in the southern right of way of Estes Drive Extension (S.R. 1780) running thence S 11° 23' 00" E 348.61 feet to an iron pipe, thence N 76° 30' 50" W 161.71 feet to an iron pipe; thence N 76° 30' 50" W 86.10 feet to an iron pipe located in the eastern right of way of Powell Street; thence N 76° 51' 00" W 66.45 feet to an iron pipe located in the western right of way of Powell Street; thence N 76° 29' 00" W 247.69 feet to an iron pipe; thence N 76° 29' 00" W 216.68 feet to an iron pipe located in the southern right of way of Estes Drive Extension (S.R. 1780); thence with the southern right of way of Estes Drive Extension (S.R. 1780) in a general northeasterly direction along a 557.97 foot radius curve to the right, said curve having a chord bearing and distance of N 62° 17' 17" E 248.62 feet, to an iron pipe in the southern right of way of Estes Drive Extension (S.R. 1780); thence continuing with the southern right of way of Estes Drive Extension (S.R. 1780) N 75° 09' 40" E 321.76 to an iron pipe, the point and place of beginning, containing 2.42 acres, more or less.

Legal Description: Facilities Parcel Division

Beginning at an iron pipe located in the southern right of way of Estes Drive Extension (S.R. 1780) running thence S 21° 31' 42" E 346.01 feet to an iron pipe; thence S 86°46' 22" E 1109.76 feet to a point; thence N 00° 41' 32" E 744.68 feet to a point; thence N 33° 28' 00" W 319.16 feet to a point in the southern right of way of Estes Drive Extension (S.R. 1780); thence with the southern right of way of Estes Drive Extension (S.R. 1780) in a general northwesterly direction along a 2019.02 foot radius curve to the right, said curve having a chord bearing and distance of S 53° 57' 42" W 586.01 feet, to a point in the southern right of way of Estes Drive Extension (S.R. 1780); thence continuing with the southern right of way of Estes Drive Extension S 64° 46' 47" W 685.46 feet to an iron pipe, the place and point of beginning, containing 18.13 acres, more or less.

ZONING ATLAS AMENDMENT APPLICATION



TOWN OF CHAPEL HILL
Planning Department
405 Martin Luther King Jr. Blvd
phone (919) 969-5066 fax (919) 969-2014
www.townofchapelhill.org

Parcel Identifier Number (PIN): 9789-24-7373, 9789-03-3163 Date: March 8, 2018

Section A: Project Information

Project Name: Town and University Joint Services Center
Property Address: Unaddressed Zip Code: 27514
Use Groups (A, B, and/or C): B Existing Zoning District: OI-2
Project Description: A rezoning from OI-2 to U-1 to facilitate a Development Agreement that will allow for the Town Municipal Services Center and future University Uses.

Section B: Applicant, Owner, and/or Contract Purchaser Information

Applicant Information (to whom correspondence will be mailed)

Name: Aaron Frank, Town of Chapel Hill Planning & Development Services
Address: 405 Martin Luther King Jr. Blvd
City: Chapel Hill State: NC Zip Code: 27514
Phone: 919-969-5059 Email: afrank@townofchapelhill.org

The undersigned applicant hereby certifies that, to the best of their knowledge and belief, all information supplied within this application is true and accurate.

Signature:  Date: 3/15/18

Owner/Contract Purchaser Information (9789-24-7373):

Owner Contract Purchaser

Name: The University of North Carolina at Chapel Hill
Address: 300 South Building - CB #1000
City: Chapel Hill State: North Carolina Zip Code: 27599-1000
Phone: 919-962-3795 Email: annaw@fac.unc.edu

The undersigned applicant hereby certifies that, to the best of their knowledge and belief, all information supplied within this application is true and accurate.

Signature:  Date: 03.15.2018



**ZONING ATLAS AMENDMENT APPLICATION
SUBMITTAL REQUIREMENTS**
TOWN OF CHAPEL HILL
Planning Department

Owner/Contract Purchaser Information (9789-03-3163):

Owner

Contract Purchaser

Name: Trustees, University of North Carolina at Chapel Hill Endowment Fund
 Address: 300 South Building – CB #1000
 City: Chapel Hill State: North Carolina Zip Code: 27599-1000
 Phone: 919-962-3795 Email: jpruitt@unc.edu

The undersigned applicant hereby certifies that, to the best of their knowledge and belief, all information supplied within this application is true and accurate.

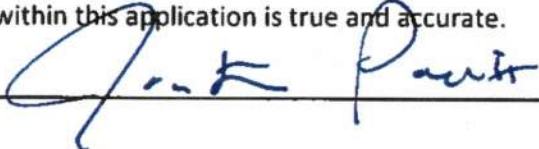
Signature:  Date: 3-15-2018

The following must accompany your application. Failure to do so will result in your application being considered incomplete. For assistance with this application, please contact the Chapel Hill Planning Department (Planning) at (919) 969-5066 or at planning@townofchapelhill.org. For detailed information, please refer to the Description of Detailed Information handout.

N/A	Application fee (refer to fee schedule)	Amount Paid \$	<input type="text" value="N/A"/>
Yes	Pre-Application Meeting – with appropriate staff		
Yes	Digital Files – provide digital files of all plans and documents		
Yes	Mailing list of owners of property within 1,000 foot perimeter of subject property (see GIS notification tool)		
N/A	Mailing fee for above mailing list	Amount Paid \$	<input type="text"/>
Yes	Written Narrative describing the proposal		
Yes	Statement of Justification		
Yes	Digital photos of site and surrounding properties		
Yes	Legal description of property to be rezoned		
Yes	Phasing Plan (if applicable) indicating phasing boundaries and phasing notes		
Yes	Reduced Site Plan Set (reduced to 8.5" x 11")		

Plan Sets (10 copies to be submitted no larger than 24" x 36")

Plans should be legible and clearly drawn. All plan set sheets should include the following:

- Project Name
- Legend
- Labels

- North Arrow (North oriented toward top of page)
- Property Boundaries with bearing and distances
- Scale (Engineering), denoted graphically and numerically
- Setbacks
- Streams, RCD Boundary, Jordan Riparian Buffer Boundary, Floodplain, and Wetlands Boundary, where applicable

Area Map

- a) Project name, applicant, contact information, location, PIN, & legend
- b) Dedicated open space, parks, greenways
- c) Overlay Districts, if applicable
- d) Property lines, zoning district boundaries, land uses, project names of site and surrounding properties, significant buildings, corporate limit lines
- e) 1,000 foot notification boundary

Town University Joint Services Center Rezoning Application

Written Narrative

March 14, 2018

Orange County PINs 9789-24-7373, 9789-03-3163, ~20.55 acres

Introduction & Background

The Town has identified the need for a new Municipal Service Center facility and initiated an effort to identify potential sites that would meet the functional, operational, and location needs for several Town departments including the police, parks and recreation administration, fire department administration, health and wellness clinic, ombuds, and training. The Town also recognized this as an opportunity to facilitate increased collaboration, shared training, operations, and public services for Town operations.

The Town tested the capacity of a University-owned site on Estes Drive, recognizing that a coordinated effort could meet long-term interests for both the Town and the University. The site-test shows that there is a significant opportunity to develop a plan for the property that respects the site constraints, the neighboring properties, and complements the planned Carolina North campus. Co-location of certain functions could enhance operations, facilitate shared responses, and encourage joint training and planning for public safety or other uses.

In 2017, Town Council authorized the Town Manager to proceed with a development agreement for the site, and separately in 2017 the University Board of Trustees agreed to consider a lease that would set the groundwork for the Town and University to move forward with a project.

The “property” consists of two unaddressed parcels 9789-24-7373, 9789-03-3163, owned by the University of North Carolina and the University of North Carolina Endowment Fund, respectively. The project area contains approximately 20.55 acres. Of the 9789-24-7373 parcel, the project only encompasses the portion of this parcel that is currently zoned Office Institutional-2.

Property Rezoning & Development Agreement

The property is proposed to be rezoned from Office/Institutional-2 (OI-2) to University-1 (U-1) to allow for a maximum of 200,000 square feet, up to 50% of which may be occupied by the Town. The Town proposes to develop a portion of the property first with the future Town Municipal Services Center in an approximately ~72,000 square foot building. A 99 year lease is proposed and will accommodate the long-term timeline for future development of additional University and Town buildings.

The rezoning is proposed from Office/Institutional-2 to University-1 to facilitate the companion development agreement. A development agreement is an instrument suited to permit long-range implementation of a development program, shared infrastructure between the University and the Town, and a customized set of development standards. The University-1 (U-1) district is designed as a carrying district for a development agreement authorizing public uses such as civic and university uses, which are being proposed. The baseline permitted land uses within a U-1 zoning district are those within the Office/Institutional-4 district, a district designed primarily for University uses. The proposed permitted land uses with this application are refined further from this list to reflect compatibility with neighboring properties and the programmatic needs of the Town and the University. Notably, certain

land uses that are permitted within U-1 but generally regarded as more intense, such as *General Business, Service Stations*, will be prohibited by this Development Agreement.

A conceptual site plan accompanies the rezoning application and provides the anticipated general building and infrastructure layout of the site. This site plan was designed with input from adjacent property owners and University representatives. Site specific standards regarding site design and performance standards are proposed in the development agreement that reflect these conversations. Notably, vehicular access is prohibited to the south through the Elkin Hills neighborhood, buildings have been pushed towards Estes Drive, and a 100'+ vegetated buffer is proposed adjacent to the neighborhood to provide a harmonious transition to the adjacent neighborhood.

Draft development agreement standards are provided as an attachment to this application and will be refined further with continued discussion with community members, advisory boards, Town staff, and University staff. Six focused community meetings were held with community members prior to review by advisory boards and commissions.

Project Description

The University-1 zoning district intends for public or private development notably for university and civic uses. While the first user will be the Municipal Services Center the order of following development phases remains to be determined. However, the Municipal Services Project aims to limit the development envelope only to earthwork necessary for the Municipal Services Center and associated infrastructure. The infrastructure included in the first phase of development will include two vehicular accesses (as required for police access), parking only as needed for the Municipal Services Center (to limit development footprint), and stormwater management facilities that will meet the stormwater quantity and quality requirements for the anticipated full build-out by the Town and the University.. Stormwater management is anticipated through bio-retention basins, located at the southern portions of the site. These facilities are planned at depressed areas of the site to accommodate natural drainage patterns to the extent possible within the existing development footprint.

The project is designed with a centralized plaza between the primary buildings of the site, and a drive aisle will encircle the buildings leading to the two vehicular accesses; one of which is planned to match with the UNC park & ride access. Buildings have been brought towards Estes Drive in order to allow for greater buffering from the Elkin Hills neighborhood, and buildings and parking structures are proposed to be constructed into the hillside to limit relative height and land disturbance required for construction.

A 100'+ buffer of existing vegetation is proposed and a buffer is provided adjacent to the intermittent streams located on-site. Sanitary sewer will be connected from the south via Hartig Street, and a break in the buffer is required for this utility connection. A greenway is proposed to connect Justice Street to the Municipal Services Center for a non-vehicular connection as proposed in the Mobility & Connectivity Plan.

Three intermittent streams are located on the property and no development is planned within the 50' RCD except for the internal drive aisle, which is designed to cross the RCD perpendicularly to minimize disturbance.

Rezoning Statement of Justification
Town University Joint Services Center
March 21, 2018

Introduction

The Town and the University of North Carolina are seeking a rezoning from Office-Institutional-2 (OI-2) to University-1 (U-1) to facilitate the development of Town and University services on University-owned land. A rezoning to U-1 is necessary in order to accommodate the Development Agreement proposed between the Town and University. A Development Agreement is the appropriate zoning instrument to facilitate a long-term development partnership between the Town and University. The Town is pursuing a 99-year lease and build-out is anticipated within this period; a Special Use Permit would not allow for a long-term build-out during this timeframe. A total of 200,000 square feet of floor area, of which up to 50% may be occupied by the Town, is proposed across multiple buildings, and the Town anticipates constructing the Municipal Services Center in the immediate future to address Town needs. The remaining balance of square footage will be constructed by the University and the Town within the lease period although a timeline has not been established.

The project exists on two parcels, one of which contains the existing Giles Horney Building and other University services along Airport Drive. A zoning change is only requested for the OI-2-zoned portion of the property.

Compatibility with the Comprehensive Plan

This statement of justification demonstrates how the project aligns with goals of the Comprehensive Plan.

A Place for Everyone

The Municipal Services Center and surrounding grounds will be publicly accessible and the site will feature a pedestrian plaza, trails, and open space that may be used as amenities by the public. A design goal for the project is to create a pleasurable environment both for employees who work at the Municipal Services Center as well as for members of the public who visit the site. Ideally this property will be an amenity for nearby residents as well. The site will be accessible by multiple modes of transportation utilizing a proposed bus stop on Estes Drive, a greenway connection to Justice Street, and bicycle lanes on Estes Drive.

- *Family-friendly, accessible exterior and interior places throughout the town for a variety of active uses (PFE.1)*
- *A creative place to live, work, and play because of Chapel Hill's arts and culture (PFE.2)*
- *A community of high civic engagement and participation (PFE.5)*

Getting Around

The project is sited and designed in a way to promote multi-modal transportation opportunities for employees and visitors of the site. The users of the first phase of project development will be Town

employees, who are encouraged by the Town to use a variety of commuting options. The site is situated to capitalize on multi-modal transportation opportunities in the following ways:

Transit: The project site is located on Estes Drive and directly served by the NU and HS transit routes, and is less than half a mile from Martin Luther King Jr. Blvd, served by NS, G, T, and A routes. A bus stop is planned for on Estes Drive.

Bicycle: The property will be accessed by bicycle through bicycle lanes that may be provided on Estes Drive Extension, and bicycle parking shall be provided to meet Town standards. A Transportation Management Plan shall be submitted and reviewed on an annual basis to meet the Town's satisfaction.

Pedestrian: A greenway is proposed into the site via Justice Street and will provide connectivity and recreational opportunities for users of the municipal services center as well as residents from the surrounding neighborhood. A greenway may also be constructed along Estes Drive to provide future pedestrian connectivity along this roadway.

Vehicular parking shall be built to serve the phases as they are constructed in order to minimize the development envelope.

- *A well-conceived and planned, carefully thought-out, integrated, and balanced transportation system that recognizes the importance of automobiles, but encourages and facilitates the growth and use of other means of transportation such as bicycle, pedestrian, and public transportation options (GA.1)*
- *A connected community that links neighborhoods, businesses, and schools through the provision of greenways, sidewalks, bike facilities, and public transportation (GA.2)*
- *Create a comprehensive transportation system that provides everybody safe and reasonable access to all the community offers (GA.5)*
- *A transportation system that accommodates transportation needs and demands while mitigating congestion and promoting air quality, sustainability, and energy conservation (GA.6)*

Nurturing Our Community

This project is being designed in an environmentally conscious manner and LEED certification is being pursued. The building siting and orientation is designed to optimize southern building exposure for winter solar gain, and the buildings will feature natural daylighting to minimize energy usage. The building is designed to optimize collaborative and shared spaces for the multiple users of the building, both creating an innovative work environment as well resulting in a more efficient project footprint, resulting in economic and carbon reductions. The general siting of the Municipal Services Center in this location is necessary for police to provide fast response time, as well as to locate other Town services in a centralized location within the Town.

Stormwater management may be provided in bio-retention basins and will meet or exceed the minimum Town stormwater management requirements. Stormwater rate management is anticipated to exceed the 25-year, 24-hour storm event and the stormwater volume management may exceed the 2-year, 24-hour storm event. The final conditions and type of stormwater control measure will be determined when final engineering is performed. The project aims to provide maximum stormwater volume and rate control using bio-retention

basins located within the proposed development footprint. The first one inch of precipitation shall be treated to remove 85% of total suspended solids of all new impervious surfaces resulting from development anticipated at full build-out by the Town and the University, and the project shall meet Jordan Watershed Stormwater requirements for Nitrogen and Phosphorous removal. The Jordan Watershed Stormwater requirements for Nitrogen and Phosphorus are required as this project is located on State owned property and remains subject to these requirements.

A 50' RCD buffer is provided surrounding each of the intermittent streams of the site, and the driveway crossing has been designed to cross the buffer area in a perpendicular manner to reduce encroachment.

Attention has been given to the impact of stormwater runoff, light, noise pollution, and traffic to the adjacent neighborhood. The project will be designed with glare control light fixtures, and use of timed or photocell lights is being evaluated. The location of buildings has been designed close to Estes Drive in response to community feedback about visual impact of buildings to the surrounding properties.

Vehicular traffic is prohibited from the Elkin Hills neighborhood to prevent any traffic impacts to this residential area. A Transportation Impact Analysis has been performed and improvements to Estes Drive including a dedicated center turn lane will be provided.

- *Maintain and improve air quality and water quality, and manage stormwater to heal local waterways and conserve biological ecosystems within the town boundaries and the Extra Territorial Jurisdiction (NOC.2)*
- *Reduce the carbon footprint of all Town-owned or managed services and properties; require that all new development meets standards; and support residents in minimizing their personal footprints (NOC.7)*
- *Protect neighborhoods from the impact of development such as stormwater runoff, light and noise pollution, and traffic (NOC.8)*

Good Places, New Spaces

This project is a result of coordination between the University (property owner) and the Town to utilize the property that fits the needs of both the users, visitors of the property, as well as adjacent property owners. Environmental protection is proposed by consciously limiting the development envelope and maintaining a vegetative buffer along the periphery of the site. This project will serve an integral role in the Town's growth by offering new space for critical Town services, and also serving as an open gathering space accessible to the community.

The proposed use aligns with the future land use map and the form and density is proposed in such a manner to meet Town needs while maintaining compatibility with adjacent properties.

- *A joint Town/University development strategy that aligns initiatives for transportation, housing, environmental protection, and entrepreneurial programs (GPNS.4)*
- *Open and accessible common spaces for community gathering, cultural uses, and community development (GPNS.7)*
- *Future land use, form, and density that strengthen the community, social equity, economic prosperity, and natural environment (GPNS.8)*

Town and Gown Collaboration

This project is a collaborative effort between the Town and University to meet respective organizational interests while respecting the land and adjacent properties. Prior to filing of this rezoning application the Town project team has met several times with community members, University stakeholders, and reported project progress to Town Council to receive feedback.

- *The University, the UNC Health Care System, and the Town will coordinate closely to manage development in ways that respect history, traditions, and the environment while fostering revitalization and innovation (TGC.5)*

Municipal Services Center Photographs

View of site from Justice Street



View of site from Hartig Street



View of site from Powell Street



View from northeast



View from Southeast



View from Park & Ride



9.78E+09	GOFORTH I PO BOX 20 RALEIGH NC	2.76E+08
9.78E+09	POWELL AS 604 IRONW CHAPEL HII NC	27516
9.78E+09	DAVIS LESL 100 EASTRI CHAPEL HII NC	2.75E+08
9.78E+09	GARRETT N 108 HARDV CHAPEL HII NC	27516
9.78E+09	THACKER C 109 HARDV CHAPEL HII NC	27516
9.78E+09	FARLEY WII 105 HARDV CHAPEL HII NC	27516
9.78E+09	ADALSTEIN 104 EASTRI CHAPEL HII NC	2.75E+08
9.78E+09	HARDY RAL 616 IRONW CHAPEL HII NC	27516
9.78E+09	HEWETT C/ 104 BURLV CHAPEL HII NC	2.75E+08
9.78E+09	SHYAM KAI 101 EASTRI CHAPEL HII NC	27516
9.78E+09	WILLIAMS ` 102 BURLV CHAPEL HII NC	27517
9.78E+09	BAKER TAN 101 NORTH CHAPEL HII NC	2.75E+08
9.78E+09	GAERTNER 103 EASTRI CHAPEL HII NC	27516
9.78E+09	CHEN TSUN 105 EASTRI CHAPEL HII NC	2.75E+08
9.78E+09	ORANGE U 1220 MAR` CHAPEL HII NC	27514
9.78E+09	POON CHI 102 NORTH CHAPEL HII NC	27516
9.78E+09	BROWN M. 102 MARIG CHAPEL HII NC	2.75E+08
9.78E+09	WRIGHT ST 103 MARIG CHAPEL HII NC	27516
9.78E+09	KUCERA JO 104 NORTH CHAPEL HII NC	27516
9.78E+09	DENT GEO F 106 NORTH CHAPEL HII NC	2.75E+08
9.78E+09	SUBRAMAN 108 NORTH CHAPEL HII NC	27516
9.78E+09	WHITEHEA 104 MARIG CHAPEL HII NC	2.75E+08
9.78E+09	BURK ALBE 105 MARIG CHAPEL HII NC	2.75E+08
9.78E+09	PENDZICH 110 NORTH CHAPEL HII NC	2.75E+08
9.79E+09	WASHINGT 320 SEVERI CHAPEL HII NC	27516
9.79E+09	WANG TIAI 301 SEVERI CHAPEL HII NC	27516
9.79E+09	MCCOMBS 8211 TERR/ NORTHVILL MI	48167
9.79E+09	AUFDERHA 805 WARD CHAPEL HII NC	27516
9.79E+09	DANIEL JO F 5 OAKHUR` DECATUR GA	30030
9.79E+09	SOMERS S/ 405 BARCL CHAPEL HII NC	27516
9.79E+09	HUMPHRE` 801 WARD CHAPEL HII NC	2.75E+08
9.79E+09	BROWN GE 304 WESLY Chapel Hill NC	27516
9.79E+09	RUSSELL EL 832 WARD CHAPEL HII NC	27516
9.79E+09	MORSE MA 824 WARD CHAPEL HII NC	27516
9.79E+09	HAWKINS [401 BARCL CHAPEL HII NC	27516
9.79E+09	ODONNELL 808 WARD CHAPEL HII NC	2.75E+08
9.79E+09	WEISENSTE 810 WARD CHAPEL HII NC	2.75E+08
9.79E+09	RUSSELL SC 820 WARD CHAPEL HII NC	27516
9.79E+09	TLALKA IRE 11711 DELI RALEIGH NC	27617
9.79E+09	RICHMONC 4718 TIMB DURHAM NC	27707
9.79E+09	SMITH ROE 2144 RETAI CHARLOTTI NC	2.83E+08
9.79E+09	HEWITT ST. 804 WARD CHAPEL HII NC	2.75E+08
9.79E+09	ECONOME` PO BOX 16I CHAPEL HII NC	27516
9.79E+09	FRANTZ EM 325 BARCL CHAPEL HII NC	27516
9.79E+09	SLEDGE RO 328 BARCL CHAPEL HII NC	27514
9.79E+09	GUNN THO 324 BARCL CHAPEL HII NC	27516
9.79E+09	SCHARLOC I 805 POWEI CHAPEL HII NC	2.75E+08

9.79E+09	ECONOME PO BOX 16 CHAPEL HII NC	27516
9.79E+09	FAHERTY K 108 S HILLS HILLSBORO NC	2.73E+08
9.79E+09	WOOD JAN 817 POWE CHAPEL HII NC	27516
9.79E+09	DE BRUYN 316 SEVERI CHAPEL HII NC	2.75E+08
9.79E+09	BARCLAY M 2422 MOLL ROXBORO NC	27574
9.79E+09	SOUROULL 320 BARCL CHAPEL HII NC	2.75E+08
9.79E+09	THEISEN G 312 SEVERI CHAPEL HII NC	27514
9.79E+09	BELL JOHN 317 BARCL CHAPEL HII NC	27514
9.79E+09	SQUIRES S 18 POWELL CHAPEL HII NC	2.75E+08
9.79E+09	BEER KIM C 308 SEVERI CHAPEL HII NC	27516
9.79E+09	MARKS JAY 3712 HAWI CHAPEL HII NC	27516
9.79E+09	MUMBY D 800 POWE CHAPEL HII NC	2.75E+08
9.79E+09	ZELDIN LES 804 POWE CHAPEL HII NC	27516
9.79E+09	RADZICKA J 506 MANO Carrboro NC	27510
9.79E+09	MOORING P O BOX 33 LA GRANGI NC	2.86E+08
9.79E+09	HINKLE DIA 304 SEVERI CHAPEL HII NC	2.75E+08
9.79E+09	FULCHER L 3931 KELLY DURHAM NC	27707
9.79E+09	FLAXMAN C 312 BARCL CHAPEL HII NC	27516
9.79E+09	UNIVERSIT ENDOWME CHAPEL HII NC	27514
9.79E+09	SMITHERS J 273 SEVERI CHAPEL HII NC	2.75E+08
9.79E+09	ROMEL JO 403 WESLE CHAPEL HII NC	27516
9.79E+09	MCCORMIK 401 WESLE CHAPEL HII NC	27516
9.79E+09	MULCAHY J 300 SEVERI CHAPEL HII NC	27516
9.79E+09	SCHWARTZ 2017 S LAK CHAPEL HII NC	27514
9.79E+09	NAIDEN FR 308 BARCL Chapel Hill NC	27516
9.79E+09	NEEBE ALIC 1002 HIGH CHAPEL HII NC	27517
9.79E+09	MELVIN AN 3805 MANI CHAPEL HII NC	27516
9.79E+09	MULCAHY J 300 SEVERI CHAPEL HII NC	27516
9.79E+09	CLEMENTS 301 BARCL CHAPEL HII NC	27516
9.79E+09	HEARN RA 933 AUTUN CLOVER SC	29710
9.79E+09	BURKE SIGI P O BOX 45 CHAPEL HII NC	27515
9.79E+09	MANTON P PO BOX 14 CARRBORO NC	27510
9.79E+09	LANE NAN 786 WEINE CHAPEL HII NC	2.75E+08
9.79E+09	SKAKLE SYE 269 SEVERI CHAPEL HII NC	2.75E+08
9.79E+09	WILLIAMS J 1 WEINER CHAPEL HII NC	27516
9.79E+09	NEAL ANNE 239 HEMP CHARLOTTI NC	2.82E+08
9.79E+09	NEAL ANNE 239 HEMP CHARLOTTI NC	2.82E+08
9.79E+09	MARKWAY 804 HARTI CHAPEL HII NC	27516
9.79E+09	HUMPHRIE 802 HARTI CHAPEL HII NC	27516
9.79E+09	BLACK SEM 265 SEVERI CHAPEL HII NC	27516
9.79E+09	HACKNEY J 104 CAROL CHAPEL HII NC	27514
9.79E+09	SCOTT JENI 231 BARCL CHAPEL HII NC	2.75E+08
9.79E+09	THIEDA PA 226 BARCL CHAPEL HII NC	27516
9.79E+09	BLACK SEM 265 SEVERI CHAPEL HII NC	27516
9.79E+09	DAYSON CL 257 SEVERI CHAPEL HII NC	27516
9.79E+09	OKUN CAR 260 SEVERI CHAPEL HII NC	27516
9.79E+09	VAUGHAN 229 BARCL CHAPEL HII NC	27516

9.79E+09	DIVARIS KII 227 BARCL CHAPEL HII NC	27516
9.79E+09	FLASH BET 750 WEAVI CHAPEL HII NC	2.75E+08
9.79E+09	PARKS RON 8401 CEDA CHAPEL HII NC	27516
9.79E+09	SCHARLOC 253 SEVERI CHAPEL HII NC	27516
9.79E+09	RAPER JULI 248 SEVERI CHAPEL HII NC	2.75E+08
9.79E+09	BARFIELD C PO BOX 20 MCCALL SC	27570
9.79E+09	MOORE AN 220 BARCL CHAPEL HII NC	27516
9.79E+09	LEHNER RIC 375 WESLE CHAPEL HII NC	27516
9.79E+09	ANDERSON 247 SEVERI CHAPEL HII NC	27516
9.79E+09	GERARDEN 107 POLKS CHAPEL HII NC	27516
9.79E+09	KEARNS KA 223 BARCL CHAPEL HII NC	2.75E+08
9.79E+09	OWEN JOH 4002 TROP COLUMBIA MO	6.52E+08
9.79E+09	STANG FRE 218 BARCL CHAPEL HII NC	2.75E+08
9.79E+09	CARPENTEI 377 WESLE CHAPEL HII NC	27516
9.79E+09	LYON MILD 241 SEVERI CHAPEL HII NC	27516
9.79E+09	SOADY SHE 236 SEVERI CHAPEL HII NC	27516
9.79E+09	BARRY DAN PO BOX 20 CARRBORC NC	27510
9.79E+09	SIMONSEN 216 BARCL CHAPEL HII NC	27516
9.79E+09	BRICE CARL 379 WESLE CHAPEL HII NC	27516
9.79E+09	MATTHEW 235 SEVERI CHAPEL HII NC	27516
9.79E+09	GARDNER S 4828 OLD DURHAM NC	2.77E+08
9.79E+09	SWANSON 229 THOM HILLSBORO NC	27278
9.79E+09	BROEK THC 215 BARCL CHAPEL HII NC	27516
9.79E+09	SMITH JOA 1505 W LA DURHAM NC	2.77E+08
9.79E+09	GURGANUS P O BOX 16 HILLSBORO NC	27278
9.79E+09	KILLOUGH 208 JUSTIC CHAPEL HII NC	2.75E+08
9.79E+09	CHANTON P O BOX 12 TALLAHASS FL	32302
9.79E+09	RHODES M 998 WILDE LINDEN VA	22642
9.79E+09	BISHOP EL 4 WYRICK S CHAPEL HII NC	27516
9.79E+09	WILLIAMS 209 JUSTIC Chapel Hill NC	27516
9.79E+09	LANE GREG 100 BUCK T CHAPEL HII NC	27516
9.79E+09	MILLS FAM P O BOX 52 SNOW CAN NC	27349
9.79E+09	UNIVERSIT UNKNOWN CHAPEL HII NC	27514
9.79E+09	LEDUC BRI 381 WESLE CHAPEL HII NC	27516
9.79E+09	BEHREND 229 SEVERI CHAPEL HII NC	2.75E+08
9.79E+09	CANOUTAS 224 SEVERI CHAPEL HII NC	27516
9.79E+09	JOLLEY VIR 115 WOOD DURHAM NC	27713
9.79E+09	ANDERSON 223 SEVERI CHAPEL HII NC	2.75E+08
9.79E+09	MCIVER JO 218 SEVERI CHAPEL HII NC	27516
9.79E+09	BAROFF RC 240 BUTEO PITTSBORC NC	27312
9.79E+09	REECE ROB 385 WESLE CHAPEL HII NC	27516
9.79E+09	SEVERIN ST 31 ROGERS CHAPEL HII NC	27514
9.79E+09	NEAL ANNE 239 HEMP S CHARLOTTI NC	28207
9.79E+09	BARROW R 209 BARCL CHAPEL HII NC	2.75E+08
9.79E+09	STABLER DI 123 PRIEST CHAPEL HII NC	2.75E+08
9.79E+09	PETTIFOR A 389 WESLE CHAPEL HII NC	27516
9.79E+09	PERKINS RC 211 SEVERI CHAPEL HII NC	27516

9.79E+09 HANEY MA 208 SEVERI CHAPEL HII NC	2.75E+08
9.79E+09 BROWN SU 304 WESLE CHAPEL HII NC	27516
9.79E+09 MILLS NATI PO BOX 67I CARRBORC NC	27510
9.79E+09 PALIOURAS 393 WESLE Chapel Hill NC	27516
9.79E+09 MILLS NATI PO BOX 67I CARRBORC NC	27510
9.79E+09 MATTHEW 205 SEVERI CHAPEL HII NC	2.75E+08
9.79E+09 PACE SHAN 721 BRADL CHAPEL HII NC	2.75E+08
9.79E+09 HEITSCH D 727 BRADL CHAPEL HII NC	2.75E+08
9.79E+09 KCC VENTU PO BOX 12 RALEIGH NC	27605
9.79E+09 MATTHEW 205 SEVERI CHAPEL HII NC	27514
9.79E+09 MATTHEW 205 SEVERI CHAPEL HII NC	27516
9.79E+09 ROBERTS L 749 WILLIA CHAPEL HII NC	2.75E+08
9.79E+09 MCLEOD JC 737 BRADL CHAPEL HII NC	27516
9.79E+09 LEITNER FR 112 TIMBEI CHAPEL HII NC	27514
9.79E+09 COGGER LI 739 WILLIA CHAPEL HII NC	27516
9.79E+09 TORNERO \ 731 WILLIA CHAPEL HII NC	2.75E+08
9.79E+09 KEY REBEC 735 WILLIA CHAPEL HII NC	27516
9.79E+09 ELLIOTT CA 3 WYRICK S CHAPEL HII NC	27516
9.79E+09 WOLF MER 104 BLACKI CARRBORC NC	2.75E+08
9.79E+09 SAUNDERS 385 MEAD(Chapel Hill NC	27517
9.79E+09 FEW JAME 517 ROBIN CHAPEL HII NC	27516
9.79E+09 HEWETT M 803 BRANC Chapel Hill NC	27516
9.79E+09 O'KEEFE D 805 BRANC CHAPEL HII NC	27516
9.79E+09 STURGESS 3000 GALLI PITTSBORC NC	27312
9.79E+09 RADEMAC 7 BRANCH : CHAPEL HII NC	27516
9.79E+09 STARBACK 206 BARCL CHAPEL HII NC	27516
9.79E+09 THOMAS P. PO BOX 95: Chapel Hill NC	27515
9.79E+09 BROWN GE 200 JUSTIC CHAPEL HII NC	27516
9.79E+09 JAHANNIA 800 BRANC CHAPEL HII NC	27516
9.79E+09 BARNEY KR 5 BRANCH : CHAPEL HII NC	27516
9.79E+09 SUMMERS 1923 EPHE: CHAPEL HII NC	27517
9.79E+09 KALOUDIS . 96 LORRAI MONTCLAI NJ	7043
9.79E+09 OBLER JEFF 1830 17TH WASHINGT DE	20009
9.79E+09 BROWN GE 304 WESLE CHAPEL HII NC	27516
9.79E+09 NISBET A P 919 OXBOV CHAPEL HII NC	27516
9.79E+09 ABERNETH 143 GOAH CHAPEL HII NC	27516
9.79E+09 GERARDEN 107 POLKS Chapel Hill NC	27516
9.79E+09 ROBERTS D 749 WILLIA CHAPEL HII NC	2.75E+08
9.79E+09 CARTER MI 102 SERENI CHAPEL HII NC	27516
9.79E+09 KIM EUN A 212 E WINI CHAPEL HII NC	27516
9.79E+09 BERRY ANN 132 JUSTIC CHAPEL HII NC	27516
9.79E+09 WALKER C 716 CASWE CHAPEL HII NC	27514
9.79E+09 GIBSON KE 1755 RIDGI ATLANTA GA	3.03E+08
9.79E+09 CAMPBELL 406 BROAC Carrboro NC	27510
9.79E+09 SHAPLEY Q 130 JUSTIC CHAPEL HII NC	2.75E+08
9.79E+09 CRANNY TI 328 UMSTE CHAPEL HII NC	27516
9.79E+09 CAMPBELL 406 BROAC Carrboro NC	27510

9.79E+09	FLASH BET 750 WEAVI	CHAPEL HII NC	2.75E+08
9.79E+09	MCADAMS 8505 ORAN	CHAPEL HII NC	2.75E+08
9.79E+09	TAL LLC 1924 MT SI	Chapel Hill NC	27514
9.79E+09	BAKER JAS(124 JUSTIC	CHAPEL HII NC	27516
9.79E+09	EDMONDS 740 WILLIA	CHAPEL HII NC	27516
9.79E+09	WHITE JOH 2207 WHIT	RALEIGH NC	2.76E+08
9.79E+09	MERTZ JAN 15541 QUE	FORT MYE FL	3.39E+08
9.79E+09	DE MARCO 120 JUSTIC	Chapel Hill NC	27514
9.79E+09	SPARROW 727 WILLIA	CHAPEL HII NC	27516
9.79E+09	SCHNURR E 736 WILLIA	CHAPEL HII NC	27516
9.79E+09	BRINKHOU 1162 FEARI	PITTSBORO NC	27312
9.79E+09	JOHNSON E 734 WILLIA	CHAPEL HII NC	27516
9.79E+09	LEONARD I 304 SEVERI	CHAPEL HII NC	2.75E+08
9.79E+09	OCHOA TO 730 WILLIA	CHAPEL HII NC	27516
9.79E+09	SINGH MOI 728 WILLIA	CHAPEL HII NC	27516
9.79E+09	CICCONE A 33 SPINNIN	MARLTON NJ	8053
9.79E+09	MALINOW 83 GRASSY	CHAPEL HII NC	27517
9.79E+09	DINO ROCK 875 MARTI	CHAPEL HII NC	27514
9.79E+09	ELKINS J W 2511 COLG	FAYETTEVIL NC	2.83E+08
9.79E+09	DINO ROCK 103 MARIG	CHAPEL HII NC	27516
9.79E+09	A&W REAL 315 PALAF	CHAPEL HII NC	27516
9.79E+09	WEHR PETI 300 SUNSE	HOLLY SPR NC	27540
9.79E+09	HUENING M UNIT 19	CHAPEL HII NC	2.75E+08
9.79E+09	SAVIT PROI 510 APPLE	MEBANE NC	27302
9.79E+09	SALEM COL 875 MARTI	CHAPEL HII NC	27514
9.79E+09	WORLEY DI 9004 ONEA	RALEIGH NC	2.76E+08
9.79E+09	KRAMER SE 875 MLK JR	CHAPEL HII NC	27516
9.79E+09	WILSON N/ 4060 E HAF	BURLINGTO NC	27215
9.79E+09	LI LI 3852 WINC	JAMESTON NC	27282
9.79E+09	ZIEMENDO 875 MARTI	CHAPEL HII NC	27514
9.79E+09	JOHNSON F 1549 TAYL	CHIAWASSEI GA	3.05E+08
9.79E+09	JW&S HOLI 2207 WHIT	RALEIGH NC	27608
9.79E+09	SIMON ERI 119 JUSTIC	CHAPEL HII NC	27516
9.79E+09	THORNHILL 405 JOHNS	CHAPEL HII NC	27514
9.79E+09	BULBROOK 118 JUSTIC	Chapel Hill NC	27514
9.79E+09	KNIGHT ALI 119 BARCL	CHAPEL HII NC	27516
9.79E+09	MILLS FAM P O BOX 52	SNOW CAN NC	27349
9.79E+09	MOORE SC 816 PINEHI	CHAPEL HII NC	27517
9.79E+09	STUBBS TH 308 MUIRF	MEBANE NC	27302
9.79E+09	ORTIZ MAR 115 BARCL	Chapel Hill NC	27516
9.79E+09	KAIROS VEI 601 W ROS	CHAPEL HII NC	27516
9.79E+09	RESNICK M 102 GURNE	Chapel Hill NC	27517
9.79E+09	WILLIAMS . 110 JUSTIC	CHAPEL HII NC	27516
9.79E+09	JOLLEY VIR 115 WOOD	DURHAM NC	27713
9.79E+09	ROBERTS D 749 WILLIA	CHAPEL HII NC	2.75E+08
9.79E+09	STATE OF N 1321 MAIL	RALEIGH NC	2.77E+08
9.79E+09	STATE OF N 1321 MAIL	RALEIGH NC	2.77E+08

9.79E+09	STRATFORI PO BOX 98	RALEIGH	NC	27624
9.79E+09	PETTY KRIS 100 BARCL	CHAPEL HII	NC	27516
9.79E+09	MILLS NATI 602 DAVIE	Carrboro	NC	27510
9.79E+09	CHAPEL HII 302 OAK T	CHAPEL HII	NC	27517
9.79E+09	CHAPEL HII 302 OAK T	CHAPEL HII	NC	27517
9.79E+09	FGV VII LLC 870 MARTI	Chapel Hill	NC	27517
9.79E+09	LEGACY CR 316 SWIFT	DURHAM	NC	27713
9.79E+09	SULIK MEL/ 199 MERIV	VASS	NC	28394
9.79E+09	CEDAR RID PO BOX 13	DURHAM	NC	2.77E+08
9.79E+09	CEDAR RID PO BOX 13	DURHAM	NC	2.77E+08
9.79E+09	CARVER CH 890 MARTI	CHAPEL HII	NC	27514
9.79E+09	MEDICAL F CB#7565 8	CHAPEL HII	NC	27516
9.79E+09	FGV VII LLC 870 MARTI	CHAPEL HII	NC	27514
9.79E+09	CORNERSTI SUITE 200	CHAPEL HII	NC	27514
9.79E+09	EMMERSO CUSTODIA	CHAPEL HII	NC	27514
9.79E+09	CHIMCO II 940 MARTI	CHAPEL HII	NC	27514
9.79E+09	PEGASUS P SUITE 200	CHAPEL HII	NC	27514
9.79E+09	SAWMILL C PO BOX 15	CHAPEL HII	NC	27514
9.79E+09	AMITY UNI 825 ESTES	CHAPEL HII	NC	27514
9.79E+09	BUTLER KA 404 WOOD	APEX	NC	27523
9.79E+09	CHAPEL HII 92 RIVER R	SUMMIT	NJ	7901
9.79E+09	GOFORTH J PO BOX 20	RALEIGH	NC	27619
9.79E+09	CHILUKURI 15 MT BOL	CHAPEL HII	NC	27514
9.79E+09	KIRK WILLI/ 121 MAPLE	CHAPEL HII	NC	2.75E+08
9.79E+09	CHARMFOF 2375 CRES	SANFORD	FL	32771
9.79E+09	NEXT LEVEL 4411 E LA	FANAHEIM	CA	92807
9.79E+09	GOFORTH I PO BOX 20	RALEIGH	NC	2.76E+08
9.79E+09	GIJOLU LLC 319 PROVII	CHAPEL HII	NC	27514
9.79E+09	PEACE JAM 11020 CHA	LOS ANGEL	CA	90077
9.79E+09	SAWMILL C P O BOX 15	CHAPEL HII	NC	27514
9.79E+09	CHAPEL HII 980 MARTI	CHAPEL HII	NC	27514
9.79E+09	LOTZ DANII 119 MAPLE	CHAPEL HII	NC	27514
9.79E+09	RICHARDS C 8 KENDALL	Chapel Hill	NC	27517
9.79E+09	WU YUE 122 WOOD	CHAPEL HII	NC	27514
9.79E+09	COKER WO 117 WOOD	CHAPEL HII	NC	27514

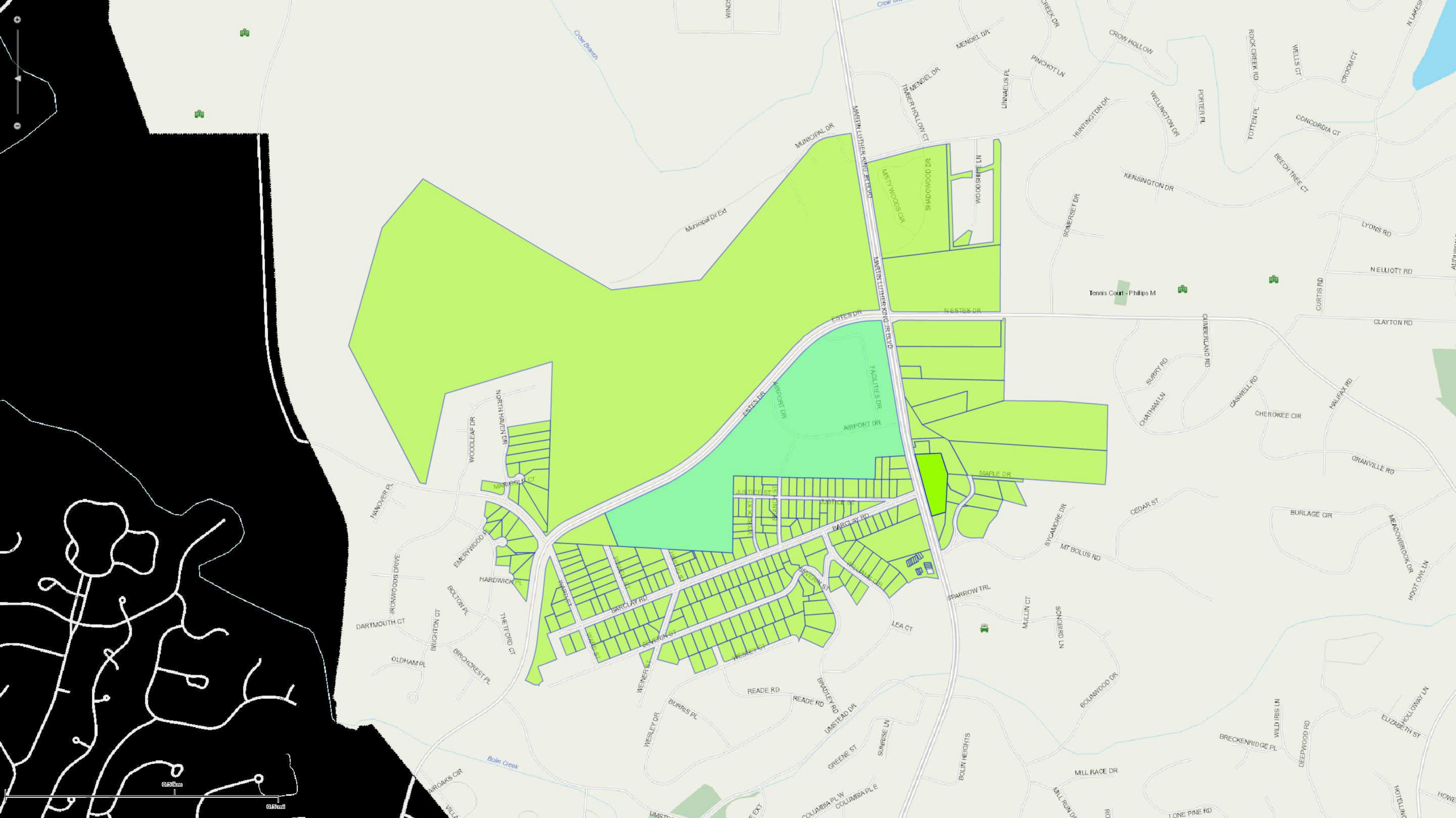

0.5 km
0.5 mi

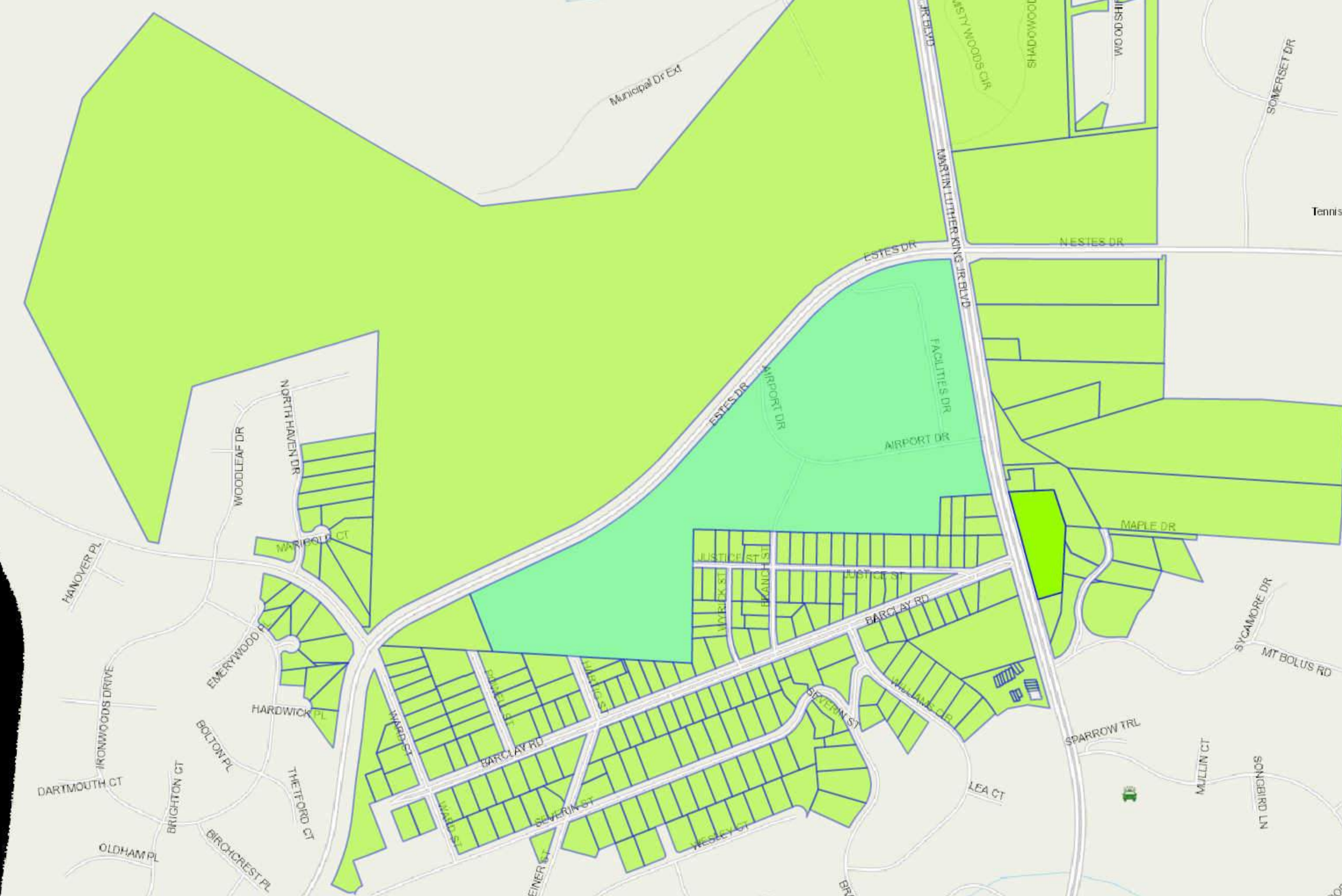

Tennis Court - Phillips M



Legal Description: Facilities Parcel Division

Beginning at an iron pipe located in the southern right of way of Estes Drive Extension (S.R. 1780) running thence S 21° 31' 42" E 346.01 feet to an iron pipe; thence S 86°46' 22" E 1109.76 feet to a point; thence N 00° 41' 32" E 744.68 feet to a point; thence N 33° 28' 00" W 319.16 feet to a point in the southern right of way of Estes Drive Extension (S.R. 1780); thence with the southern right of way of Estes Drive Extension (S.R. 1780) in a general northwesterly direction along a 2019.02 foot radius curve to the right, said curve having a chord bearing and distance of S 53° 57' 42" W 586.01 feet, to a point in the southern right of way of Estes Drive Extension (S.R. 1780); thence continuing with the southern right of way of Estes Drive Extension S 64° 46' 47" W 685.46 feet to an iron pipe, the place and point of beginning, containing 18.13 acres, more or less.

Legal Description: Former Dixon Property

Beginning at an iron pipe located in the southern right of way of Estes Drive Extension (S.R. 1780) running thence S 11° 23' 00" E 348.61 feet to an iron pipe, thence N 76° 30' 50" W 161.71 feet to an iron pipe; thence N 76° 30' 50" W 86.10 feet to an iron pipe located in the eastern right of way of Powell Street; thence N 76° 51' 00" W 66.45 feet to an iron pipe located in the western right of way of Powell Street; thence N 76° 29' 00" W 247.69 feet to an iron pipe; thence N 76° 29' 00" W 216.68 feet to an iron pipe located in the southern right of way of Estes Drive Extension (S.R. 1780); thence with the southern right of way of Estes Drive Extension (S.R. 1780) in a general northeasterly direction along a 557.97 foot radius curve to the right, said curve having a chord bearing and distance of N 62° 17' 17" E 248.62 feet, to an iron pipe in the southern right of way of Estes Drive Extension (S.R. 1780); thence continuing with the southern right of way of Estes Drive Extension (S.R. 1780) N 75° 09' 40" E 321.76 to an iron pipe, the point and place of beginning, containing 2.42 acres, more or less.

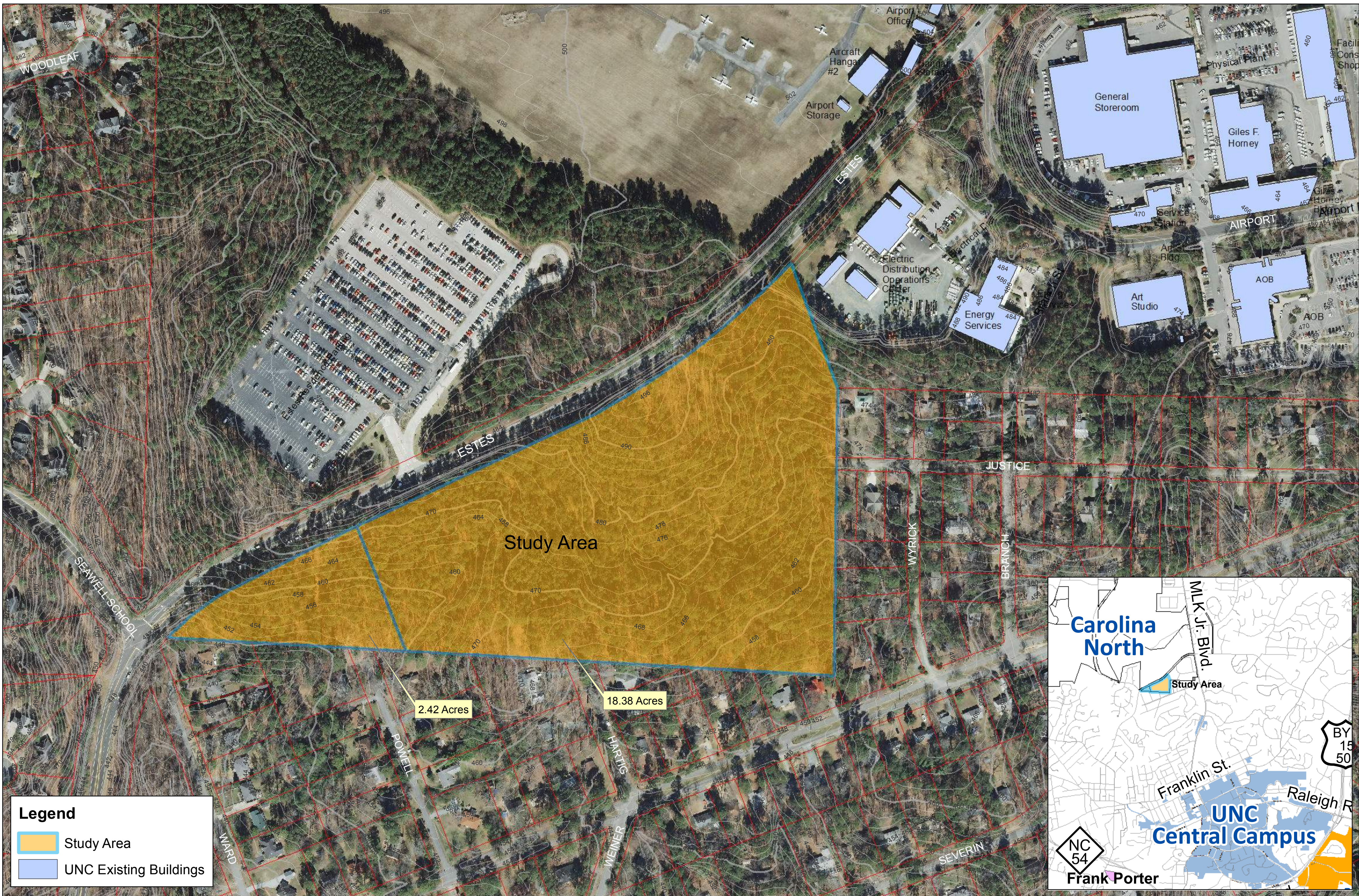

Legend

- Study Area
- UNC Existing Buildings

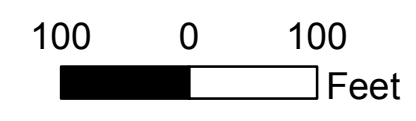
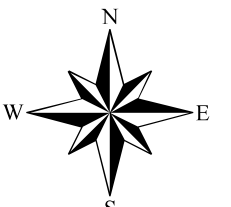

Exhibit I - Community Guiding Principles

Proposed Guiding Principles for the Municipal Services Center Development Agreement DRAFT – 1.18.2018

Residents of the Elkin Hills neighborhood and other concerned citizens who have participated in meetings about the municipal services center request that the following guiding principles be incorporated into the development agreement for this project. These guiding principles take into consideration prior documents adopted by UNC-related entities.¹

Guiding Principles

- A. After discussions with residents, the Town and the University, the final agreed-upon principles will be voted on by the Chapel Hill Town Council and incorporated into the development agreement as its guiding principles. These principles will also serve as one of the design drivers for the project.
- B. The Town and the University will continue to consult with and seek feedback from the neighborhood if and when any additional buildings beyond the municipal services center building are under consideration.
- C. Site
 - 1. Preserve in perpetuity at least 50% of the site² as natural, non-fragmented and contiguous space³ serving as both a buffer to the neighboring residential properties, and as preservation of the natural environment for wildlife and a sense of forest and greenspace.
 - 2. Allow a maximum of 50% to be razed for development.
- D. Design with Empathy
 - 1. The impact on neighbors should be kept front and center in all planning and implementation.
 - 2. The project should not decrease the market values of the residential properties adjacent and near-adjacent to the site. The residents request the Town to seek a qualified opinion from an impartial, licensed appraiser.
 - 3. Manage development of the site to minimize impacts on adjacent neighborhood and the environment,⁴ using measurable indicators of impact, including both lighting and noise impacts (e.g., sirens used by the fire and police departments) and maximize aesthetics in accordance with the high standards set by the University.
 - a) Situate buildings away from the neighborhood and by preference along Estes Drive Extension with minimum setbacks from the street.
 - b) Extend the 100-foot required buffer to at least 200 feet.
 - c) Give strong preference to higher buildings rather than lower structures that cover more surface area.
 - d) Restrict the use and storage of hazardous materials such as fuels and chemicals.
 - e) Limit the use of fences.
- E. Environmental Leadership
 - 1. Demonstrate a leadership position in environmentally sensitive development regarding air quality, and energy production and consumption.⁵⁶
 - a) Construct buildings to meet high environmental standards, such as the AIA-2030 carbon reduction energy performance standards as recommended to the Town by the Environmental Stewardship Advisory Board (ESAB).⁷
 - b) Give strong preference to a multi-storied parking garage or parking under each building on the site, rather than expanded surface parking.

- c) Construct surface parking which optimizes storm water control including the use of permeable surfaces wherever possible.
 - d) Where technically possible, incorporate green energy options into site design, e.g., solar panels on roofs, solar carports over surface parking areas.
2. Demonstrate a leadership position in environmentally sensitive development regarding landscaping and maintaining natural areas.
- a) Retain as many mature and medium-height native trees and hardwoods as possible, particularly between the developed area and the buffer for the Elkin Hills neighborhood.⁸
 - b) Use only native plants in new and replacement landscaping for the site (as recommended by UNC's NC Botanical Garden).
- F. Exceed Storm Water Requirements
1. Demonstrate a leadership position regarding sustainable water management, waste water treatment and reuse,⁹ and creek water quality.
- a) Exceed storm water management regulations on the site to eliminate or greatly decrease the risk of flooding and damage to property adjacent to and downstream from the site. Ensure that development of the site will result in no net increase in storm water discharge¹⁰ and flooding of the adjacent neighborhoods, and no net increase in loading of sediment and nutrients into local streams.¹¹
 - b) Reclaim and re-use rain and storm water (e.g., flushing within buildings, watering of vegetation, etc.).
 - c) Take prudent and reasonable steps, including improvement of stream channels in the Elkin Hills neighborhood and other neighborhoods downstream from the site, to improve management of run-off and to limit impact on Bolin Creek.

¹ These documents include: A) Carolina North 2007 Plan; B) REPORT OF THE LEADERSHIP ADVISORY COMMITTEE FOR CAROLINA NORTH January 19, 2007; C) UNC response to Horace Williams Citizens Committee report, 25 January 2006, Natural areas/parks and recreational facilities; D) Faculty Council Resolution 2002-6. Urging the University Administration to Commit Itself to Sustainability Measures in its Institutional Policies and Practices. PROPOSED BY THE BUILDINGS AND GROUNDS COMMITTEE (April 4, 2002).

² UNC response to Horace Williams Citizens Committee report, 25 January 2006, Natural areas/parks and recreational facilities, Principle 1, p. 5

³ REPORT OF THE LEADERSHIP ADVISORY COMMITTEE FOR CAROLINA NORTH, January 19, 2007, V. OPEN SPACE, NATURAL AREAS, PARKS AND RECREATION, p. 5

⁴ UNC response to Horace Williams Citizens Committee report, 25 January 2006, Development principle 1, p. 4

⁵ REPORT OF THE LEADERSHIP ADVISORY COMMITTEE FOR CAROLINA NORTH, January 19, 2007, V. OPEN SPACE, NATURAL AREAS, PARKS AND RECREATION, p. 4

⁶ Three zeros environmental initiative; Frequently asked questions; <https://threezeros.unc.edu/faq/>

⁷ CAROLINA NORTH PLANNING PROCESS SUMMARY OF KEY INTERESTS BY CATEGORY [FEBRUARY 11, 2009], p. 184

⁸ Sustainability at UNC. Grounds. <https://sustainability.unc.edu/initiatives/operations/grounds/>

⁹ UNC response to Horace Williams Citizens Committee report, 25 January 2006, Water and Sewer / Stormwater Management / Air Quality Principle 1, p. 5

¹⁰ UNC response to Horace Williams Citizens Committee report, 25 January 2006, Water and Sewer / Stormwater Management / Air Quality Principle, Principle 2, p. 5

¹¹ REPORT OF THE LEADERSHIP ADVISORY COMMITTEE FOR CAROLINA NORTH, January 19, 2007, Environmental principles, p. 4

Exhibit J - Stream Determination



PUBLIC WORKS DEPARTMENT STORMWATER MANAGEMENT DIVISION

405 Martin Luther King, Jr. Blvd.
Chapel Hill, NC 27514-5705
Telephone (919) 969-7246
Fax (919) 969-7276
www.townofchapelhill.org

February 28, 2018

Mr. Matthew West
Dewberry
2610 Wycliff Road, Suite 410
Raleigh, North Carolina 27607
mwest@dewberry.com

RE: Stream Determination for undeveloped parcel owned by UNC Endowment Fund on Estes Drive Extension, Chapel Hill, NC (PIN 9789-03-3163)

Dear Mr. West:

As requested, the Town Public Works Department has performed a stream determination for the property identified on the attached forms. This determination indicates whether different types of streams (perennial, intermittent, and/or ephemeral) or perennial waterbodies are present on the property in question or on nearby properties. These streams and their classifications are shown on the accompanying map. Stream segments regulated by the Town's Jordan Lake Watershed Riparian Buffer regulations are highlighted. **Locations of all features on the map are approximate and must be field surveyed for precise location.**

This stream determination information is used to determine the location and extent of the Resource Conservation District (RCD) and Jordan Lake Watershed Riparian Buffers. Specific land use regulations and restrictions apply within the boundaries of these protected areas. If you are considering any kind of work on this property, including clearing vegetation, paving, grading, or building, please consult with the Town Planning Department to determine the possible extent of the Resource Conservation District (RCD) and Jordan Lake Watershed Riparian Buffer on this property and the applicable corresponding regulations.

This stream determination will remain in effect for five years from the date of the site visit, after which a new stream determination with site visit will be required.

In accordance with the Town's procedures, you may appeal this administrative decision to the Town Manager. If you wish to do so, you must file your written appeal accompanied by any materials you believe support your appeal, within **30 days** of receipt of this letter.

If you have questions regarding stream determinations, please contact me at (919) 969-7202 or aweakley@townofchapelhill.org. If you have questions regarding the Town's Resource Conservation District (RCD) or the Jordan Watershed Riparian Buffer regulations, please contact the Planning Department at (919) 968-2728, or view information online at: <http://www.townofchapelhill.org/town-hall/departments-services/public-works/stormwater-management/regulations-ordinances>.

Regards,

A handwritten signature in black ink that reads "Allison Schwarz Weakley". The signature is written in a cursive style.

Allison Schwarz Weakley
Stormwater Analyst



**PUBLIC WORKS DEPARTMENT
STORMWATER MANAGEMENT DIVISION**

405 Martin Luther King, Jr. Blvd.
Chapel Hill, NC 27514-5705
Telephone (919) 969-7246
Fax (919) 969-7276
www.townofchapelhill.org

STREAM DETERMINATION SITE VISIT RESULTS

Property Information	
Parcel ID Number (PIN)	Address / Location Description
9789-03-3163	Estes Drive Extension

These are the results of a site visit to the properties listed above for a stream determination conducted on 2/23/2018 by Town Staff:

- No perennial, intermittent, or ephemeral streams or perennial waterbodies were identified on or near the property(ies) in question.
- Perennial, intermittent, or ephemeral streams, or perennial waterbodies, were identified on or near the property(ies) in question and shown on the attached map(s).

A map showing water features, their Town flow classifications, presence of Jordan Watershed Riparian Buffers, and their approximate locations is attached. Origins or breakpoints that have been flagged in the field are marked on the map. Stream classification forms and additional site visit notes and maps are also attached.

Other conditions exist which may affect the location of the Resource Conservation District or Jordan Watershed Riparian Buffer:

- FEMA floodzone is mapped in the area. Precise location of the Base Flood Elevation and associated Resource Conservation District must be determined by a field survey commissioned by the owner or a representative.
- Segments of perennial or intermittent stream are piped in the area, as shown on the map. These segments do not have an associated Jordan Watershed Riparian Buffer.
- Possible Jurisdictional Wetlands have been identified in the area. A formal review by a professional certified in Jurisdictional Wetland Delineation is recommended if impacts to wetlands are likely.

Allison Weasley

Town Staff Signature

2/28/2018
Date



**PUBLIC WORKS DEPARTMENT
STORMWATER MANAGEMENT DIVISION**

405 Martin Luther King, Jr. Blvd.
Chapel Hill, NC 27514-5705
Telephone (919) 969-7246
Fax (919) 969-7276
www.townofchapelhill.org

STREAM DETERMINATION RECORDS REVIEW

Property Information	
Parcel ID Number (PIN)	Address / Location Description
9789-03-3163	Estes Drive Extension

After reviewing Town GIS information, USGS 1:24,000 Topographic maps, and County Soil Survey maps, I have determined no new stream determination will be required for the property(ies) listed above for the following reason(s):

- No unclassified streams or waterbodies, streams or waterbodies identified as requiring a new classification or determination, or unidentified flowlines (possible streams) are shown within 150 feet of the property in question on the Town's GIS, the USGS 1:24,000 Topographic map, or the County Soil Survey map for the area.
- A Resource Conservation District boundary was set on a recorded final plat for the property in question, and there are no streams or waterbodies shown on the USGS 1:24,000 Topographic map or County Soil Survey within 150 feet of the property.
- A stream determination has been done for this property, a property uphill or upstream, or a nearby property as of February 23, 2013 or later, and that stream determination applies to this property. A copy of the documentation for the relevant site visit(s) is available upon request.

Relevant PIN(s): 9789-24-7373 (site visit 10-1-2016)

A map showing water features, their Town flow classifications, presence of Jordan Watershed Riparian Buffers, and their approximate locations is attached. Origins or breakpoints that have been flagged in the field are marked on the map.

Other conditions exist which may affect the location of the Resource Conservation District or Jordan Watershed Riparian Buffer:







- FEMA floodzone is mapped in the area. Precise location of the Base Flood Elevation and associated Resource Conservation District must be determined by a field survey commissioned by the owner or a representative.
- Segments of perennial or intermittent stream are piped in the area. These segments do not have an associated Jordan Watershed Riparian Buffer.
- Possible Jurisdictional Wetlands have been identified in the area. A formal review by a professional certified in Jurisdictional Wetland Delineation is recommended if impacts to wetlands are likely.





Alison Weasley

Town Staff signature

2/28/2018
Date

Stream Determination Area Map

- · - · - Ephemeral Stream
- - - - - Intermittent Stream
- Perennial Stream
-  Culverts
-  2-foot Contours
-  10-foot Contours
-  Buildings
-  Parcels
-  Approximate Jordan Buffer

-  Subject Property
-  Ephemeral Breakpoint
-  Intermittent Breakpoint
-  Perennial Breakpoint

Address: UNC Endowment Fund Property
 Estes Drive Extension, Chapel Hill, NC
Parcel ID: 9789-03-3163

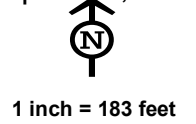
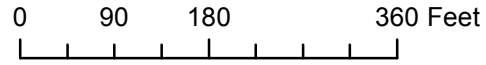

**Stream locations are approximate and must be verified by survey.
 Buffers are measured from top of bank. RCD buffers may apply.
 Please contact the Town of Chapel Hill Planning Department to verify.**

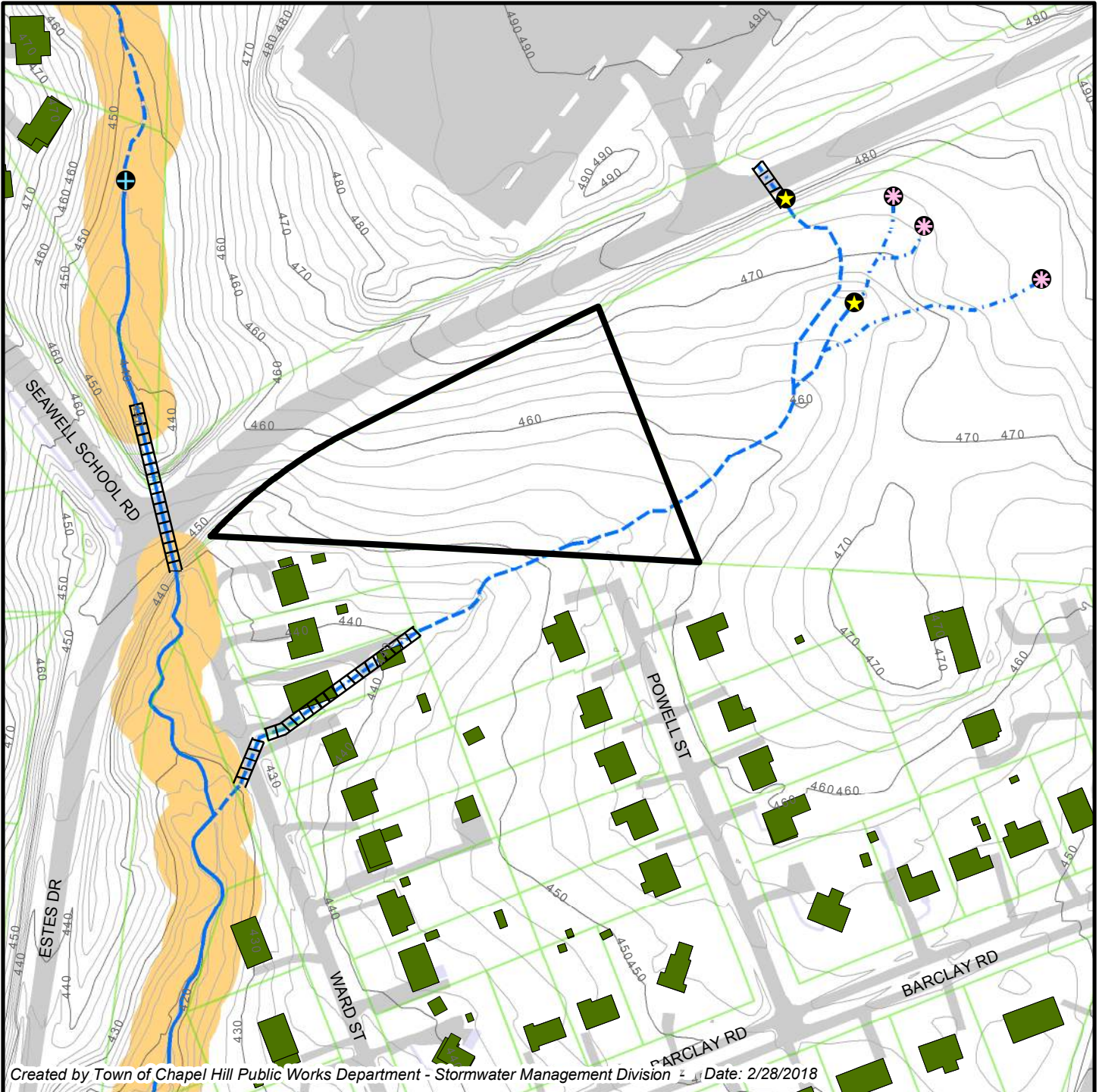

USGS 24K Topographic / County Soil Survey Maps

 Subject Property

Address: UNC Endowment Fund Property
Estes Drive Extension, Chapel Hill, NC



0 150 300 450 600 Feet

Parcel ID: 9789-03-3163

1 inch = 500 feet

Created by Town of Chapel Hill Public Works Department - Stormwater Management Division- 2/26/2018

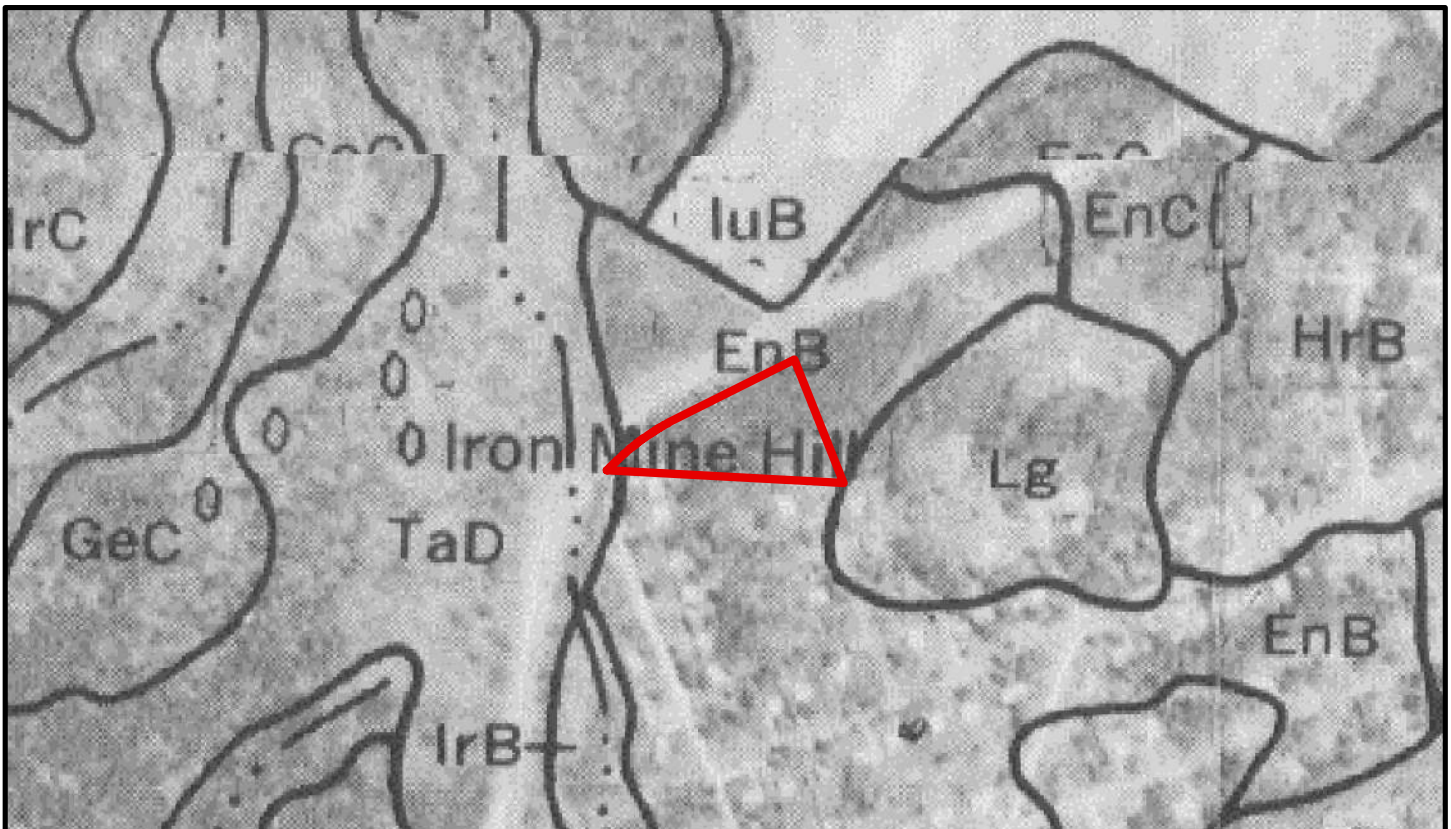
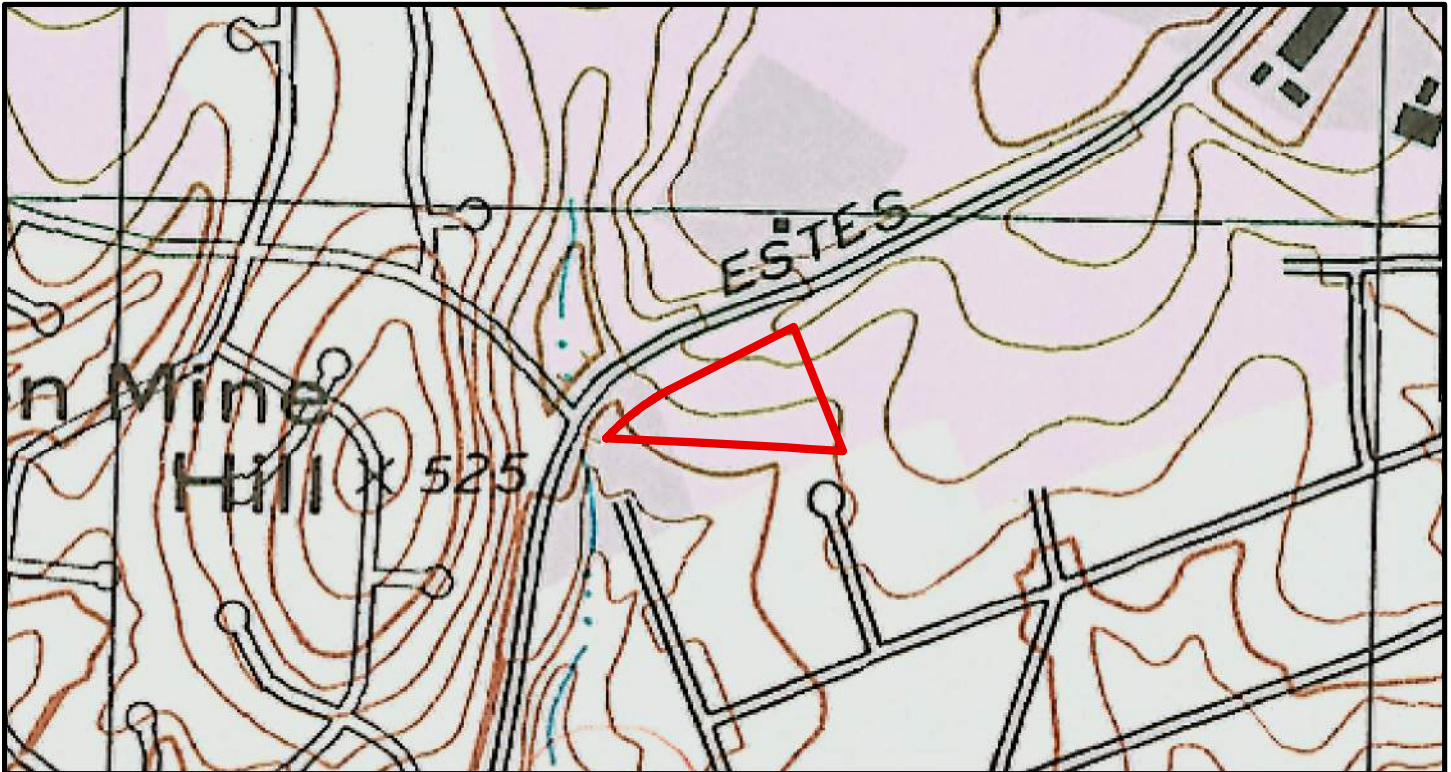

FIELD MAP 2/23/18
Estes Dr Extension
PIN 9789-03-3163

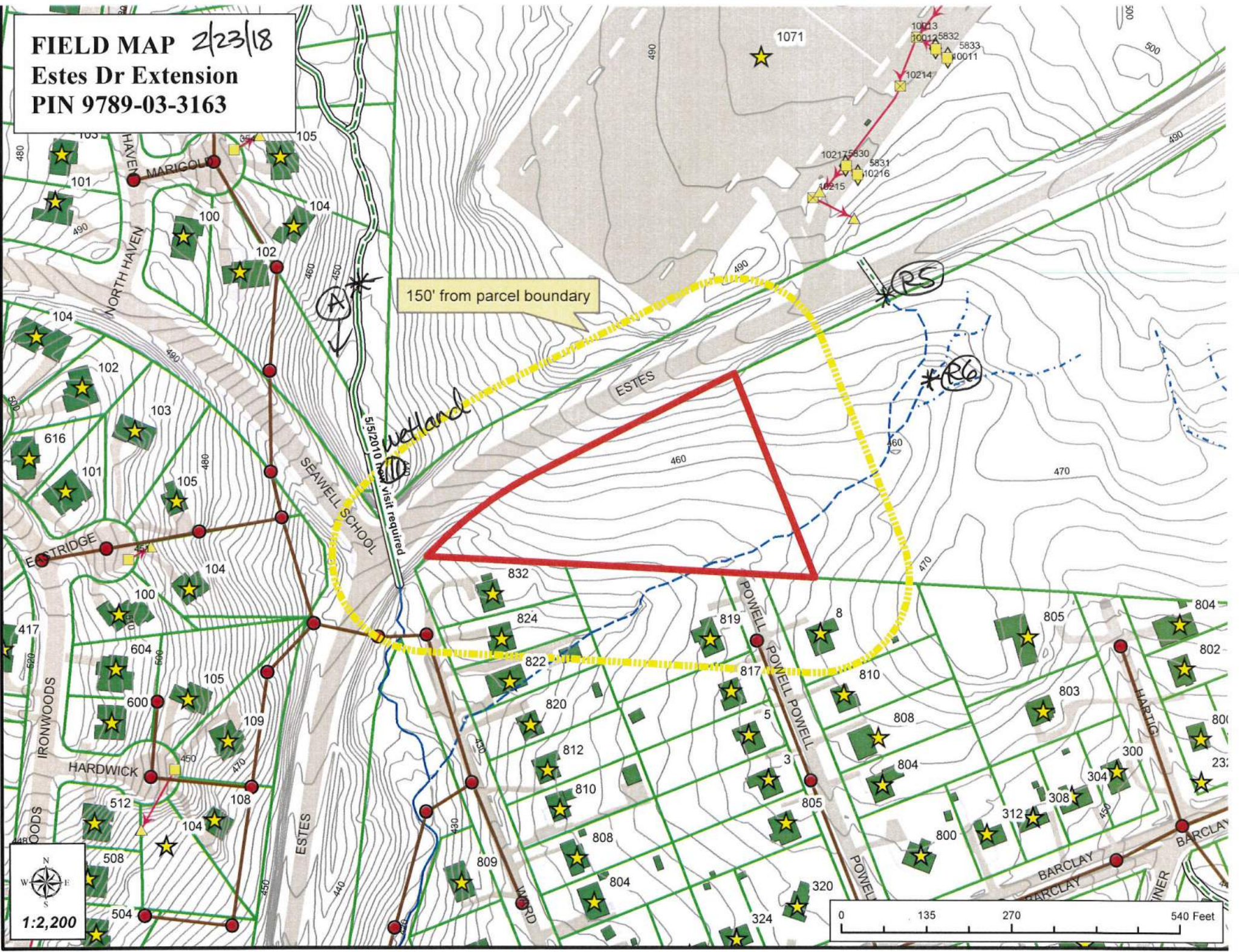

150' from parcel boundary

Wetland

1:2,200

0 135 270 540 Feet

201802231134

Estes Dr. Ext Feature (A)

NC DWQ Stream Identification Form Version 4.11

Date: 2/23/18	Project/Site: PIN 9789-03-3163	Latitude: 35.93
Evaluator: Weakley & Salat + Clarke Myers	County: Orange	Longitude: -79.067
Total Points: Stream is at least intermittent if ≥ 19 or perennial if $\geq 30^*$ 36	Stream Determination (circle one) Ephemeral Intermittent Perennial	Other e.g. Quad Name:

A. Geomorphology (Subtotal = 18)

	Absent	Weak	Moderate	Strong
1 ^a . Continuity of channel bed and bank	0	1	2	3
2. Sinuosity of channel along thalweg	0	1	2	3
3. In-channel structure: ex. riffle-pool, step-pool, ripple-pool sequence	0	1	2	3
4. Particle size of stream substrate	0	1	2	3
5. Active/relict floodplain	0	1	2	3
6. Depositional bars or benches	0	1	2	3
7. Recent alluvial deposits	0	1	2	3
8. Headcuts	0	1	2	3
9. Grade control	0	0.5	1	1.5
10. Natural valley	0	0.5	1	1.5
11. Second or greater order channel	No = 0		Yes = 3	

^a artificial ditches are not rated; see discussions in manual

B. Hydrology (Subtotal = 10.5)

12. Presence of Baseflow	0	1	2	3
13. Iron oxidizing bacteria	0	1	2	3
14. Leaf litter	1.5	1	0.5	0
15. Sediment on plants or debris	0	0.5	1	1.5
16. Organic debris lines or piles	0	0.5	1	1.5
17. Soil-based evidence of high water table?	No = 0		Yes = 3	

C. Biology (Subtotal = 7.5)

18. Fibrous roots in streambed	3	2	1	0
19. Rooted upland plants in streambed	3	2	1	0
20. Macroinvertebrates (note diversity and abundance)	0	1	2	3
21. Aquatic Mollusks	0	1	2	3
22. Fish	0	0.5	1	1.5
23. Crayfish	0	0.5	1	1.5
24. Amphibians	0	0.5	1	1.5
25. Algae	0	0.5	1	1.5
26. Wetland plants in streambed	FACW = 0.75; OBL = 1.5		Other = 0	

*perennial streams may also be identified using other methods. See p. 35 of manual.

Notes: isopods & amphipods, fish (lower reach)

Sketch: Feature begins @ headcut (flagged) & ends at box culvert @ Estes Dr. Channel shallow & dry in upper reach, but well-defined & with water flowing & in pools in lower reach. Small wetland located at base of slope on left bank, just north of Estes.



No.	DATE	BY	Description
REVISIONS			

DRAWN BY: ACH
APPROVED BY: ACH
CHECKED BY: TLH
DATE: 10/7/16

TITLE TOPOGRAPHIC SURVEY AREA

PROJECT NO. 50079224

- LEGEND**
- POST
 - POWER POLE
 - SANITARY SEWER MANHOLE
 - CLEANDUT
 - WATER METER
 - SURVEY CONTROL
 - GUY WIRE
 - IPF IRON PIPE FOUND
 - IRF IRON ROD FOUND
 - LIGHT POLE
 - MONF MONUMENT FOUND
 - RRF RAILROAD SPIKE FOUND
 - SIGN
 - UTILITY HANDHOLE
 - YARD INLET GRATE
 - WETLAND FLAG LOCATION
 - APPROX. DIRECTION OF UTILITY ORIGIN/DESTINATION UNKNOWN
 - GUARDRAIL
 - GAS LINE
 - STORM DRAIN
 - WETLAND BOUNDARY
 - FENCE
 - FIBER OPTIC
 - UNDERGROUND UTILITY
 - UNDERGROUND WATER
 - OVERHEAD ELECTRIC
 - TREELINE
 - CHAINLINK FENCE
 - DITCH
 - WOOD FENCE

- TOPOGRAPHIC SURVEY NOTES:**
- THIS TOPOGRAPHIC SURVEY IS BASED ON A SURVEY PERFORMED BY DEWBERRY ENGINEERS INC. ON SEPTEMBER 6 - OCTOBER 6, 2016.
 - HORIZONTAL CONTROL (NAD83) AND VERTICAL CONTROL (NAVD88) ESTABLISHED BY GPS OBSERVATIONS AND COMPUTED USING NORTH CAROLINA GEODETIC SOCIETY VIRTUAL REFERENCE STATION SERVICE (VRS).
 - NORTH ARROW IS GRID NORTH AND ALL DISTANCES ARE GROUND DISTANCES.
 - LOCATIONS OF UTILITIES SHOWN ON THIS SURVEY WERE DETERMINED BY OBSERVED EVIDENCE, LOCATION OF ABOVE GROUND UTILITY APPURTENANCES, AND UTILITY MARKINGS (PAINT, ETC.) PROVIDED BY NC811 FROM TICKETS #A162571203-00A AND #A162571129-00A. THESE MARKINGS WERE OBSERVED DURING THE COURSE OF THIS SURVEY, WERE FIELD LOCATED, ARE SHOWN FOR INFORMATIONAL PURPOSES, AND SHOULD BE FIELD VERIFIED IF CRITICAL. UNDERGROUND UTILITIES NOT SHOWN, MAY EXIST. STORM SEWER AND SANITARY SEWER DATA HAS BEEN COLLECTED FROM THE RIM OF THE MANHOLE WITHOUT ENTERING THE STRUCTURE. PIPE SIZES AND TYPES SHOULD BE CONSIDERED APPROXIMATE AND BE FIELD VERIFIED IF CRITICAL. STRUCTURES LABELED "VAULT", IF ANY, INDICATE A SUBSTRUCTURE WITH LIMITED VISUAL ACCESS AND INVERT INFORMATION.

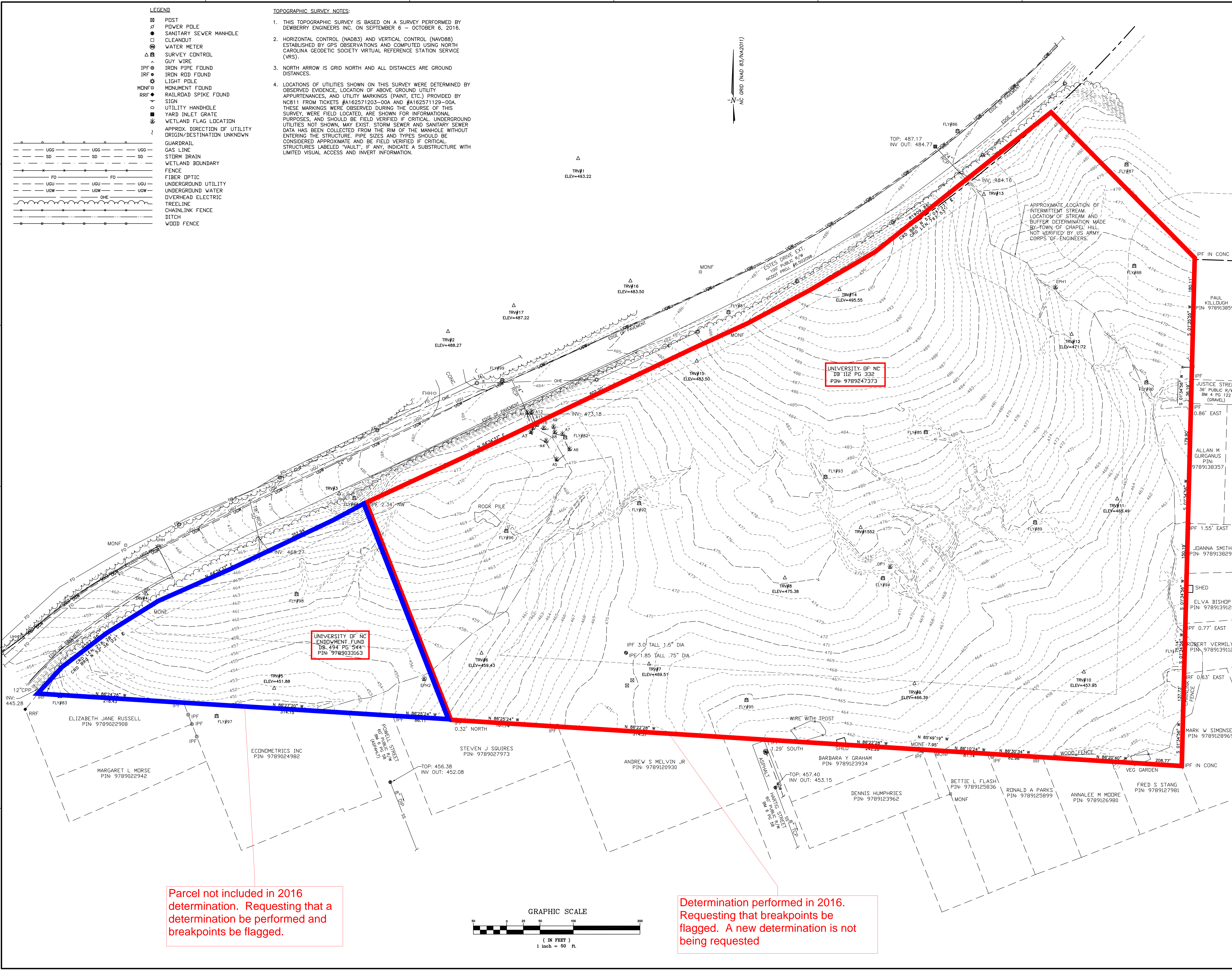

Parcel not included in 2016 determination. Requesting that a determination be performed and breakpoints be flagged.

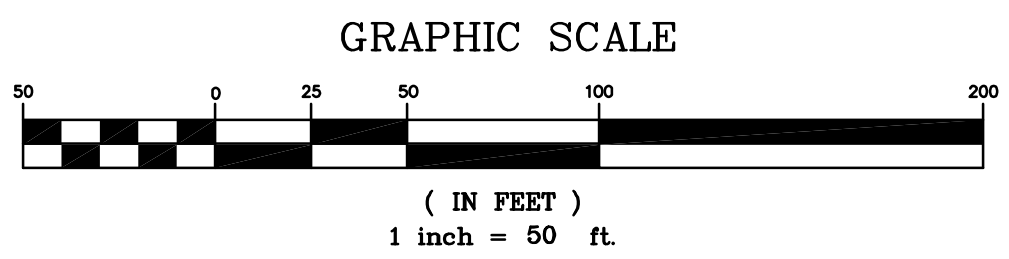

Determination performed in 2016. Requesting that breakpoints be flagged. A new determination is not being requested



5

5

e

l

i / 7

4 / 7

7 / 7

h

i : U s r) n t C

)	
	Es s v Ext
	Es s E

i ii



• • •



**PUBLIC WORKS DEPARTMENT
STORMWATER MANAGEMENT DIVISION**

405 Martin Luther King, Jr. Blvd.
Chapel Hill, NC 27514-5705
Telephone (919) 969-7246
Fax (919) 969-7276
www.townofchapelhill.org

10/7/2016

Cindy Hoffman, PLA, A SLA
Dewberry
2610 Wycliff Road, Suite 410
Raleigh, NC 27607-3366

RE: Stream Determination for Parcel #9789-24-7373

Dear Ms. Hoffman:

As requested, the Town Public Works Department has performed a stream determination on the property identified on the attached forms. This determination indicates whether different types of streams (perennial, intermittent, and/or ephemeral) or perennial waterbodies are present on the property in question or on nearby properties. These streams and their classifications are shown on the accompanying map. Stream segments regulated by the Jordan Lake Stream Buffer ordinance are highlighted. **Locations of all features on the map are approximate and must be field surveyed for precise location.**

This stream determination information is used to determine the location and extent of the Resource Conservation District and the Jordan Lake Watershed Riparian Buffer. Specific land use regulations and restrictions apply within the boundaries of these protected areas. If you are considering any kind of work on your property, including clearing vegetation, paving, grading, or building, please consult with the Town Planning Department to determine the possible extent of the Resource Conservation District and Jordan Lake Watershed Riparian Buffer on your property and corresponding regulations.

This classification will remain in effect for five years from the date of the site visit before a request for reclassification will be considered, unless the stream channel characteristics are significantly altered as a result of watershed changes.

In accordance with the Town's procedures, you may appeal this administrative decision to the Town Manager. If you wish to do so, you must file your written appeal accompanied by any materials you believe support your appeal, within **30** days of receipt of this letter.

If you have questions regarding stream determinations, please contact me at (919) 969-5083. If you have questions regarding the Town's Resource Conservation Districts or the Jordan Watershed Riparian Buffer regulations, please contact the Planning Department at (919) 968-2728, or view information online at <http://www.townofchapelhill.org/town-hall/departments-services/public-works/stormwater-management/regulations-ordinances>.

Regards,

Dave Milkereit
Stormwater Specialist



**PUBLIC WORKS DEPARTMENT
STORMWATER MANAGEMENT DIVISION**

405 Martin Luther King, Jr. Blvd.
Chapel Hill, NC 27514-5705
Telephone (919) 969-7246
Fax (919) 969-7276
www.townofchapelhill.org

STREAM DETERMINATION SITE VISIT RESULTS

Property Information	
Parcel ID Number (PIN)	Address / Location Description
9789-24-7373	101 Airport Rd/Estes Dr Extension

These are the results of a site visit to the properties listed above for a stream determination conducted on 10/6 & 10/7/2016 by Town Staff:

- No perennial, intermittent, or ephemeral streams or perennial waterbodies were identified on or near the property(ies) in question.
- Perennial, intermittent, or ephemeral streams, or perennial waterbodies, were identified on or near the property(ies) in question and shown on the attached map(s).

A map showing water features, their Town flow classifications, presence of Jordan Watershed Riparian Buffers, and their approximate locations is attached. Origins or breakpoints that have been flagged in the field are marked on the map. Stream classification forms and additional site visit notes and maps are also attached.















Other conditions exist which may affect the location of the Resource Conservation District or Jordan Watershed Riparian Buffer:

- FEMA floodzone is mapped in the area. Precise location of the Base Flood Elevation and associated Resource Conservation District must determined by a field survey commissioned by the owner or a representative.
- Segments of perennial or intermittent stream are piped in the area, as shown on the map. These segments do not have an associated Jordan Watershed Riparian Buffer.
- Possible Jurisdictional Wetlands have been identified in the area. A formal review by a professional certified in Jurisdictional Wetland Delineation is recommended.

Town Staff signature

10/7/2016
date

Stream Determination Area Map

- ⋯ Unclassified Stream
- · - · Ephemeral Stream
- - - - Intermittent Stream
- Perennial Stream
-  Culverts
-  2-foot Contours
-  10-foot Contours
-  Buildings
-  Parcels
-  Site visited
-  Non-regulated Waterbody
-  Non-perennial Waterbody
-  Wide Perennial Stream
-  Perennial Waterbody
-  Approximate Jordan Buffer
-  Ephemeral Breakpoint
-  Intermittent Breakpoint
-  Perennial Breakpoint

Address: 101 Airport Rd

Parcel ID: 9789-24-7373

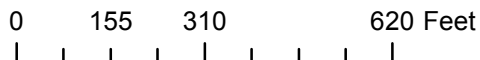

1 inch = 316 feet

Stream locations are approximate and must be verified by survey.

50' Jordan buffers shown for illustrative purposes ONLY. Wider RCD buffers may apply, please verify with TOCH Planning Department.

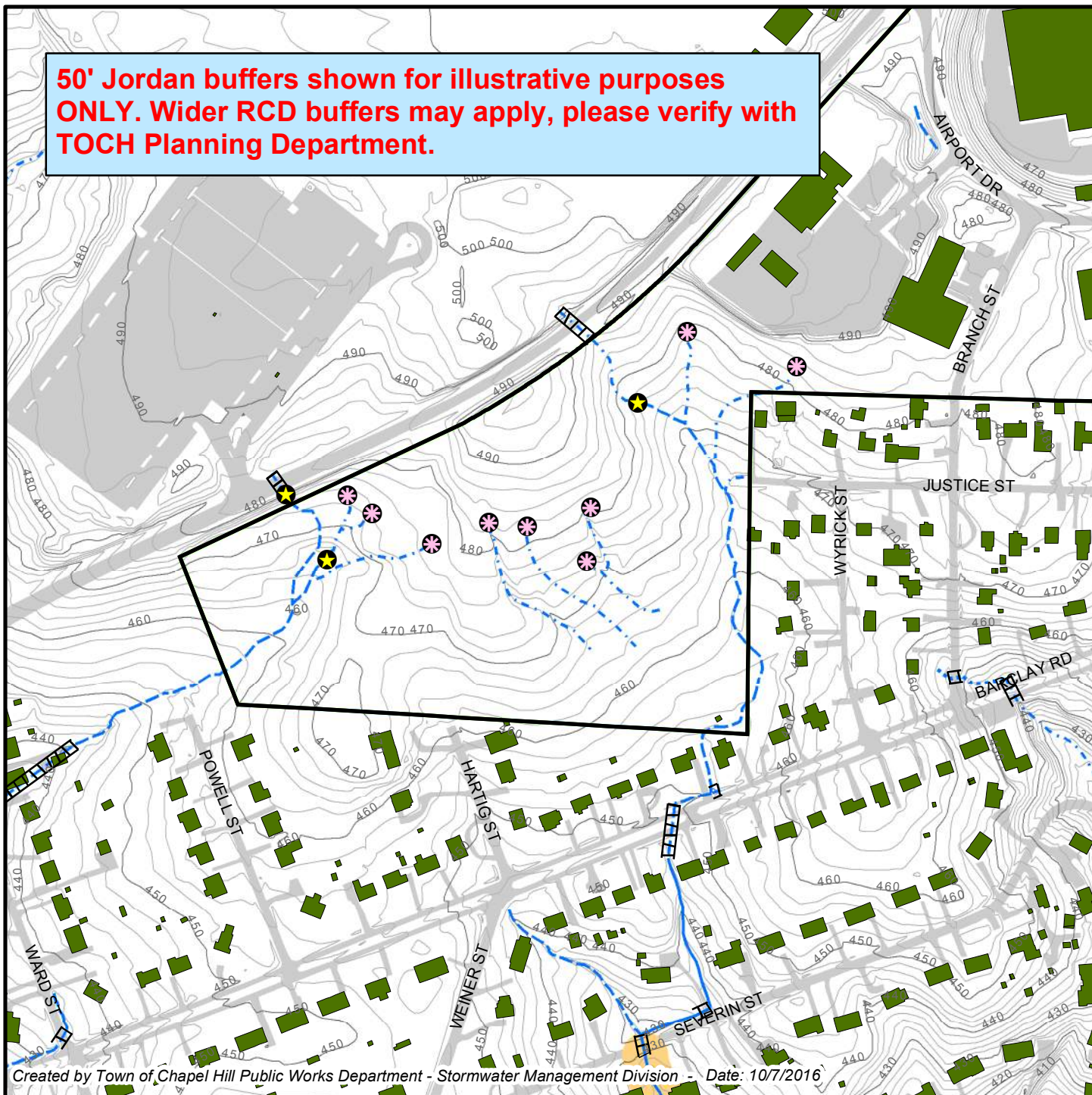

USGS 24K Topographic / County Soil Survey Maps

 Site Parcel Boundary

Address: 101 Airport Rd

0 190 380 570 760 Feet

Parcel ID: 9789-24-7373

1 inch = 625 feet



Created by Town of Chapel Hill Public Works Department - Stormwater Management Division- 9/29/2016

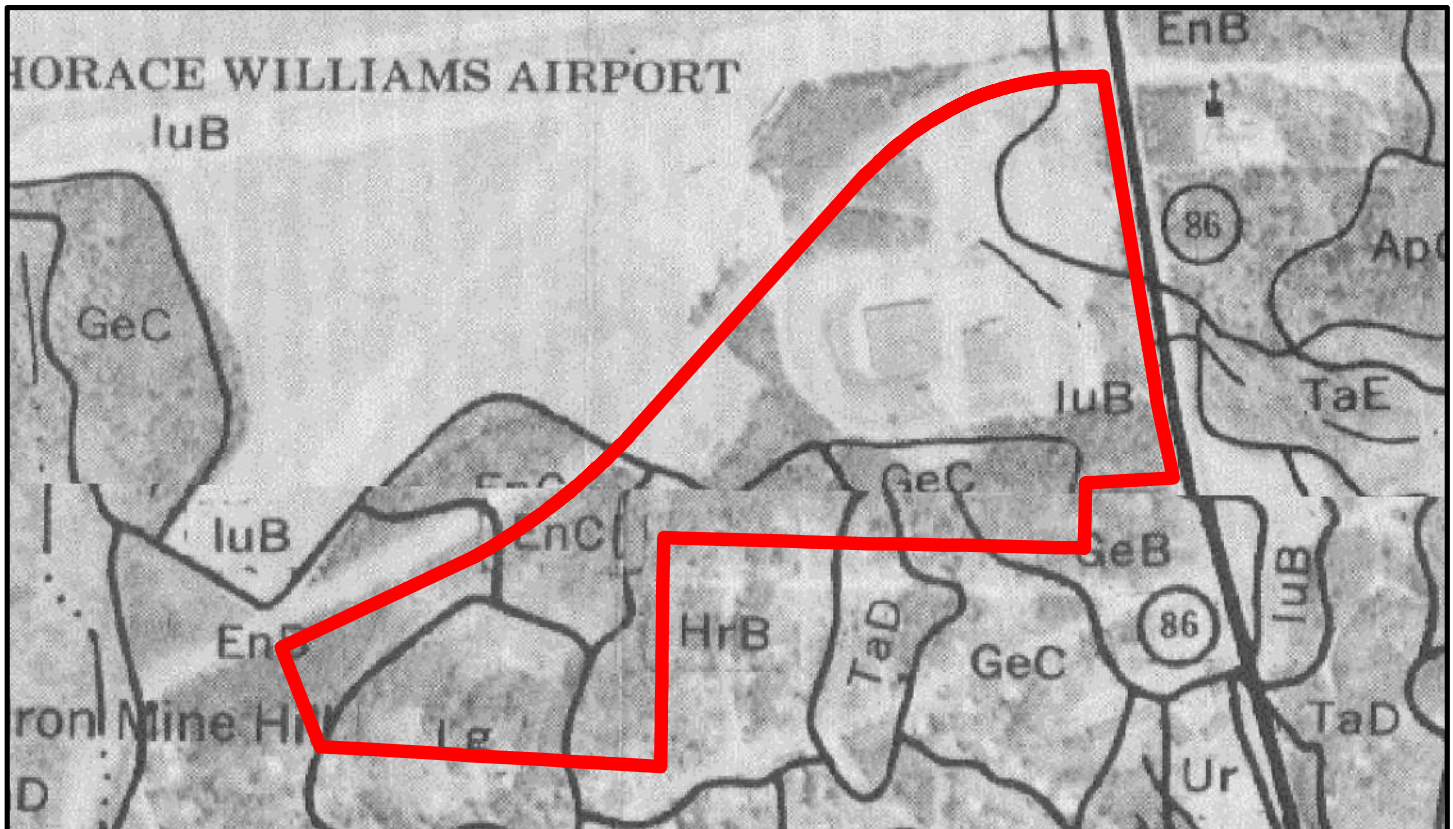
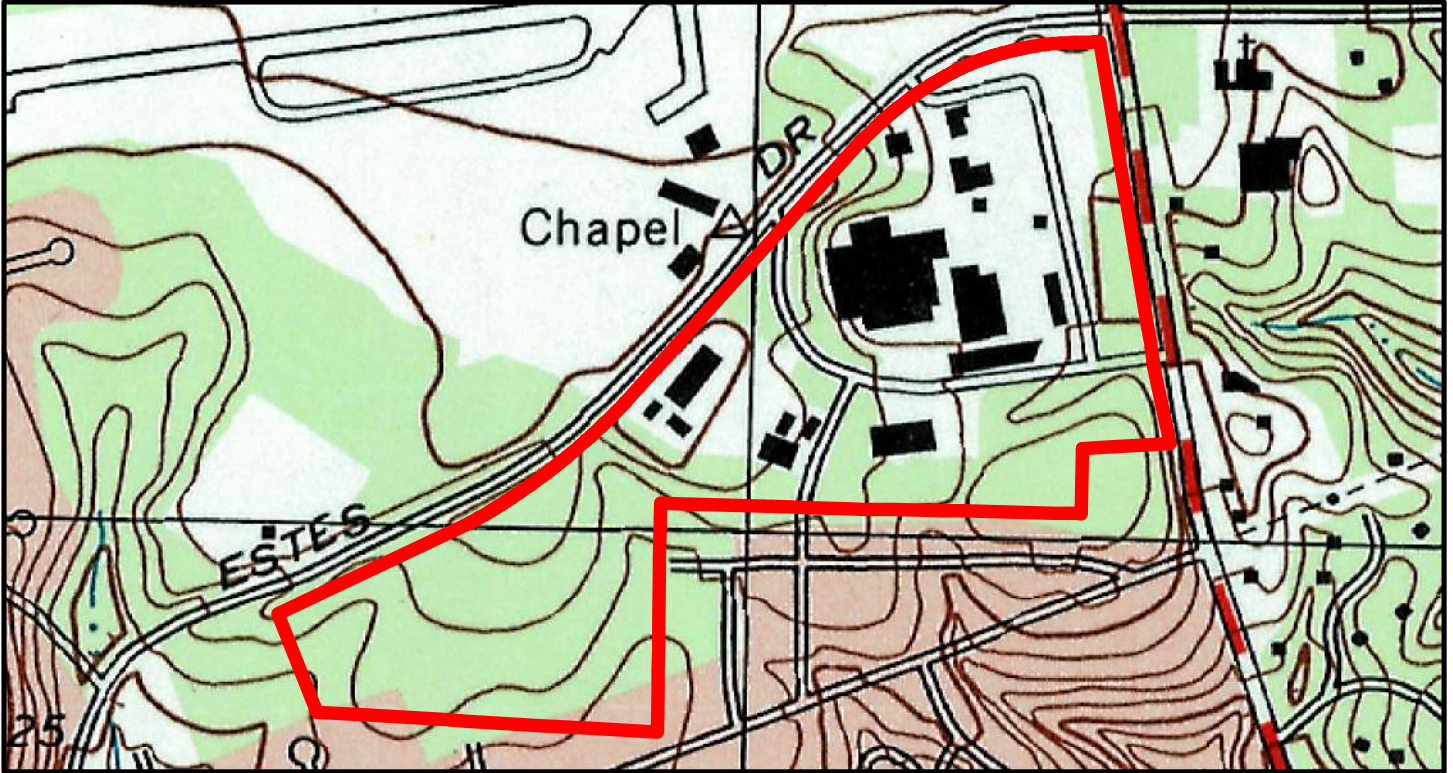

FIELD MAP 2:
101 Airport Rd
PIN 9789-24-7373
9/30/2016



1:1,477

Dashed line is 150 ft
from parcel boundary

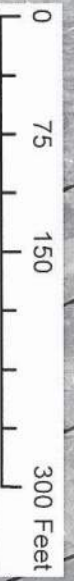
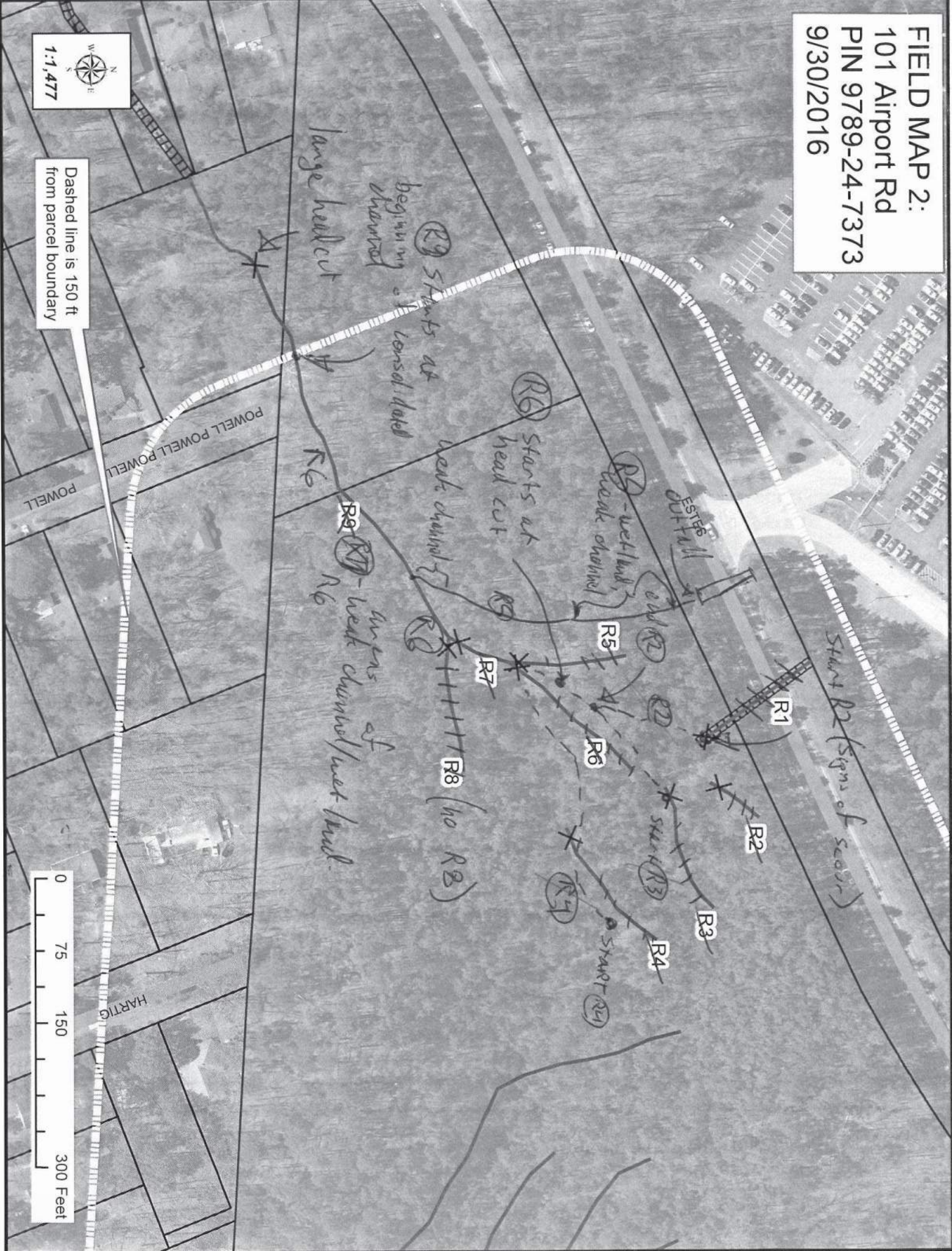

FIELD MAP 3:
101 Airport Rd
PIN 9789-24-7373
9/30/2016

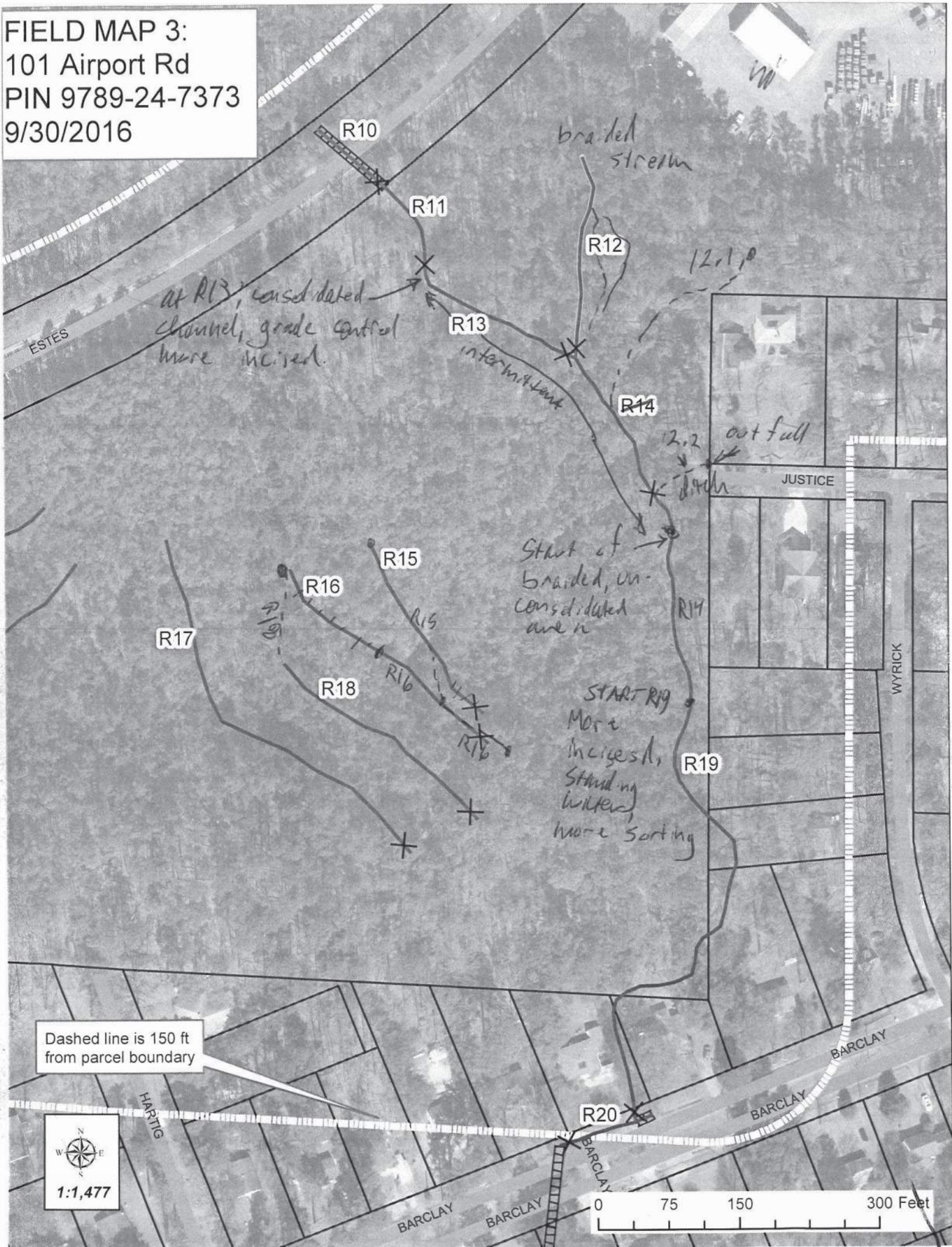

20161005243

R13

NC DWQ Stream Identification Form Version 4.11

Date:	Project Site: 9789-24-7373	Latitude:
Evaluator: DM	County:	Longitude:
Total Points: Stream is at least intermittent if ≥ 19 or perennial if ≥ 30*	Stream Determination (circle one) Ephemeral (Intermittent) Parannial	Other e.g. Quad Name:

28.75

A. Geomorphology (Subtotal = 16.5)	Absent	Weak	Moderate	Strong
1. Continuity of channel bed and bank	0	1	(2)	3
2. Sinuosity of channel along thalweg	0	1	(2)	3
3. In-channel structure (e.g. riffle-pool, step-pool, ripple-pool sequence)	0	1	(2)	3
4. Particle size of stream substrate	0	(1)	2	3
5. Active/riffle floodplain	0	1	2	(3)
6. Depositional bars or benches	0	(1)	2	3
7. Recent alluvial deposits	0	(1)	2	3
8. Headcuts	0	1	2	(3)
9. Grade control	0	0.5	(1)	1.5
10. Natural valley	0	(0.5)	1	1.5
11. Second or greater order channel	No = (0)		Yes = 3	

*artificial ditches are not rated. See discussions in manual.

B. Hydrology (Subtotal = 5.5)	Absent	Weak	Moderate	Strong
12. Presence of Baseflow	(0)	1	2	3
13. Iron oxidizing bacteria	(0)	1	2	3
14. Leaf litter	1.5	(1)	0.5	0
15. Sediment on plants or debris	0	(0.5)	1	1.5
16. Organic debris lines or piles	0	0.5	(1)	1.5
17. Soil-based evidence of high water table?	No = 0		Yes = (1)	

C. Biology (Subtotal = 6.75)	Absent	Weak	Moderate	Strong
18. Fibrous roots in streambed	3	(2)	1	0
19. Rooted upland plants in streambed	3	(2)	1	0
20. Macroinvertebrates (note diversity and abundance)	(0)	1	2	3
21. Aquatic Mollusks	(0)	1	2	3
22. Fish	(0)	0.5	1	1.5
23. Crayfish	(0)	0.5	1	1.5
24. Amphibians	(0)	0.5	1	1.5
25. Algae	0	0.5	(1)	1.5
26. Wetland plants in streambed	FACW = (0.75) OBL = 1.5 Other = 0			

*perennial streams may also be identified using other methods. See p. 35 of manual.

Notes:

S+etch. 19: Sweet gum, hickory,
26: micro stegium, smilax

1: < 25% of reach is unconsolidated

20161005268

R16

NC DWQ Stream Identification Form Version 4.11

Date: 10/5/16	Project Site: 9769-24-7373	Latitude:
Evaluator: DM	County:	Longitude:
Total Points: Stream is at least intermittent if a 3 or perennial if a 37	Stream Determination (circle one) Ephemeral Intermittent Perennial	Other e.g. Quad Name:

17.75

A. Geomorphology (Subtotal = 11)

	Absent	Weak	Moderate	Strong
1. Continuity of channel bed and bank	0	1	2	3
2. Sinuosity of channel along thalweg	0	1	2	3
3. In-channel structure ex riffle-pool step-pool rapids-pool sequence	0	1	2	3
4. Particle size of stream substrate	0	1	2	3
5. Active/riffle floodplain	0	1	2	3
6. Depositional bars or benches	0	1	2	3
7. Recent alluvial deposits	0	1	2	3
8. Headcuts	0	1	2	3
9. Grade control	0	0.5	1	1.5
10. Natural valley	0	0.5	1	1.5
11. Second or greater order channel	No = 0		Yes = 3	

*artificial ditches are not rated; see discussions in manual

B. Hydrology (Subtotal = 2)

12. Presence of Baseflow	0	1	2	3
13. Iron oxidizing bacteria	0	1	2	3
14. Leaf litter	1.5	1	0.5	0
15. Sediment on plants or debris	0	0.5	1	1.5
16. Organic debris lines or piles	0	0.5	1	1.5
17. Soil-based evidence of high water table?	No = 0		Yes = 3	

C. Biology (Subtotal = 4.75)

18. Fibrous roots in streambed	3	2	1	0
19. Rooted upland plants in streambed	3	2	1	0
20. Macroinvertebrates (more diversity and abundance)	0	1	2	3
21. Aquatic Mollusks	0	1	2	3
22. Fish	0	0.5	1	1.5
23. Crayfish	0	0.5	1	1.5
24. Amphibians	0	0.5	1	1.5
25. Algae	0	0.5	1	1.5
26. Wetland plants in streambed	FACW = 0.75 OBL = 1.5 Other = 0			

Intermittent streams may also be identified using other methods. See p. 38 of manual.

Notes:

Sketch:

20610061130

R2

NC DWQ Stream Identification Form Version 4.11

Date: 10/6/16	Project Site: 9789-21-7373	Latitude:
Evaluator: DM	County:	Longitude:
Total Points: Stream is at least intermittent if ≥ 19 or perennial if ≥ 30*	9.75	Stream Determination (circle one) Ephemeral Intermittent Perennial
		Other e.g. Quad Name:

A. Geomorphology (Subtotal = 3.5)	Absent	Weak	Moderate	Strong
1. Continuity of channel bed and bank	0	1	2	3
2. Sinuosity of channel along thalweg	0	1	2	3
3. In-channel structure (e.g. riffle-pool, step-pool, rubble-pool sequence)	0	1	2	3
4. Particle size of stream substrate	0	1	2	3
5. Active/flood floodplain	0	1	2	3
6. Depositional bars or benches	0	1	2	3
7. Recent alluvial deposits	0	1	2	3
8. Headcuts	0	1	2	3
9. Grade control	0	0.5	1	1.5
10. Natural valley	0	0.5	1	1.5
11. Second or greater order channel	No = 0		Yes = 3	

*artificial ditches are not rated; see discussions in manual

B. Hydrology (Subtotal = 1.5)	Absent	Weak	Moderate	Strong
12. Presence of Baseflow	0	1	2	3
13. Iron oxidizing bacteria	0	1	2	3
14. Leaf litter	1.5	1	0.5	0
15. Sediment on plants or debris	0	0.5	1	1.5
16. Organic debris (leaves or twigs)	0	0.5	1	1.5
17. Soil-based evidence of high water table?	No = 0		Yes = 3	

C. Biology (Subtotal = 2.75)	Absent	Weak	Moderate	Strong
18. Fibrous roots in streambed	3	2	1	0
19. Rooted upland plants in streambed	3	2	1	0
20. Macroinvertebrates (note diversity and abundance)	0	1	2	3
21. Aquatic Mollusks	0	1	2	3
22. Fish	0	0.5	1	1.5
23. Crayfish	0	0.5	1	1.5
24. Amphibians	0	0.5	1	1.5
25. Algae	0	0.5	1	1.5
26. Wetland plants in streambed	FACW = 0.75 OBL = 1.5 Other = 0			

*perennial streams may also be identified using other methods. See p. 35 of manual

Notes:

Sketch:

201610061125

R3

NC DWQ Stream Identification Form Version 4.11

Date: 10/6/16	Project Site: 9709-24-7373	Latitude:
Evaluator: DM	County:	Longitude:
Total Points: Stream is at least intermediate if 2 '3' or perennial if 3 '3'	Stream Determination (circle one) Ephemeral Intermittent Perennial	Other eg. Class Name:

15.75

A. Geomorphology (Subtotal = 8)

	Absent	Weak	Moderate	Strong
1. Continuity of channel bed and bank	0	1	2	3
2. Sinuosity of channel along thalweg	0	1	2	3
3. In-channel structure (ex riffle-pool, step-pool, rubble-pool sequence)	0	1	2	3
4. Particle size of stream substrate	0	1	2	3
5. Active helict floodplain	0	1	2	3
6. Depositional bars or benches	0	1	2	3
7. Recent alluvial deposits	0	1	2	3
8. Headcuts	0	1	2	3
9. Grade control	0	0.5	1	1.5
10. Natural valley	0	0.5	1	1.5
11. Second or greater order channel	No = 0		Yes = 3	

*artificial ditches are not rated; see discussions in manual

B. Hydrology (Subtotal = 4.5)

12. Presence of Baseflow	0	1	2	3
13. Iron oxidizing bacteria	0	1	2	3
14. Leaf litter	1.5	1	0.5	0
15. Sediment on plants or debris	0	0.5	1	1.5
16. Organic debris lines or piles	0	0.5	1	1.5
17. Soil-based evidence of high water table?	No = 0		Yes = 3	

C. Biology (Subtotal = 3.25)

18. Fibrous roots in streambed	3	2	1	0
19. Rooted upland plants in streambed	3	2	1	0
20. Macroinvertebrates (note diversity and abundance)	0	1	2	3
21. Aquatic Mollusks	0	1	2	3
22. Fish	0	0.5	1	1.5
23. Crayfish	0	0.5	1	1.5
24. Amphibians	0	0.5	1	1.5
25. Algae	0	0.5	1	1.5
26. Wetland plants in streambed	FACT = 0.75 CBL = 1.5 Other = 0			

*perennial streams may also be identified using other methods. See p. 26 of manual

Notes:

Sketch:

201610061118

R4

NC DWQ Stream Identification Form Version 4.11

Date: 10/6/16	Project Site: 9789-24-7373	Latitude:
Evaluator: DM	County:	Longitude:
Total Points: Streams at least intermittent if a 19 or perennial if a 37: 13.25	Stream Determination (circle one) Ephemeral Intermittent Perennial	Other e.g. Quad Name:

A. Geomorphology (Subtotal = 5.5)	Absent	Weak	Moderate	Strong
1. Continuity of channel bed and bank	0	1	2	3
2. Sinuosity of channel along thalweg	0	1	2	3
3. In-channel structure (e.g. riffle-pool, step-pool, noble-pool sequence)	0	1	2	3
4. Particle size of stream substrate	0	1	2	3
5. Active/riffled floodplain	0	1	2	3
6. Depositional bars or benches	0	1	2	3
7. Recent alluvial deposits	0	1	2	3
8. Headcuts	0	1	2	3
9. Grade control	0	0.5	1	1.5
10. Natural valley	0	0.5	1	1.5
11. Second or greater order channel	No = 0		Yes = 3	

*artificial ditches are not rated; see discussions in manual

B. Hydrology (Subtotal = 4.0)	Absent	Weak	Moderate	Strong
12. Presence of Baseflow	0	1	2	3
13. Iron oxidizing bacteria	0	1	2	3
14. Leaf litter	1.5	1	0.5	0
15. Sediment on plants or debris	0	0.5	1	1.5
16. Organic debris (limes or piles)	0	0.5	1	1.5
17. Soil-based evidence of high water table?	No = 0		Yes = 3	

C. Biology (Subtotal = 3.75)	Absent	Weak	Moderate	Strong
18. Fibrous roots in streambed	3	2	1	0
19. Rooted upland plants in streambed	3	2	1	0
20. Macroinvertebrates (note diversity and abundance)	0	1	2	3
21. Aquatic Mollusks	0	1	2	3
22. Fish	0	0.5	1	1.5
23. Crayfish	0	0.5	1	1.5
24. Amphibians	0	0.5	1	1.5
25. Algae	0	0.5	1	1.5
26. Wetland plants in streambed	FACW = 0.75 OBL = 1.5 Other = 0			

*perennial streams may also be identified using other methods. See p. 35 of manual.

Notes:

Sketch:

2016 10061150

RS

NC DWQ Stream Identification Form Version 4.11

Date: 10/6/16	Project Site: 9789-24-7373	Latitude:
Evaluator: DM	County:	Longitude:
Total Points: Stream is at least intermittent (# 19 or perennial (# 20))	Stream Determination (circle one) Ephemeral Intermittent Perennial	Other e.g. Quad Name:

23.25

A. Geomorphology (Subtotal = 7)	Absent	Weak	Moderate	Strong
1 ^a Continuity of channel bed and bank	0	1	2	3
2 Sinuosity of channel along the veg	0	1	2	3
3 In-channel structure (riffle-pool, step-pool, nose-pool sequence)	0	1	2	3
4 Particle size of stream substrate	0	1	2	3
5 Active/riffle floodplain	0	1	2	3
6 Depositional bars or benches	0	1	2	3
7 Recent alluvial deposits	0	1	2	3
8 Headcuts	0	1	2	3
9 Grade control	0	0.5	1	1.5
10 Natural valley	0	0.5	1	1.5
11 Second or greater order channel	No = 0		Yes = 3	

^a artificial ditches are not rated. see discussions in manual

B. Hydrology (Subtotal = 7.5)	Absent	Weak	Moderate	Strong
12 Presence of Baseflow	0	1	2	3
13 Iron oxidizing bacteria	0	1	2	3
14 Leaf litter	1.5	1	0.5	0
15 Sediment on plants or debris	0	0.5	1	1.5
16 Organic debris lines or piles	0	0.5	1	1.5
17 Soil-based evidence of high water table?	No = 0		Yes = 3	

C. Biology (Subtotal = 8.75)	Absent	Weak	Moderate	Strong
18 Fibrous roots in streambed	3	2	1	0
19 Rooted upland plants in streambed	3	2	1	0
20 Macroinvertebrates (note diversity and abundance)	0	1	2	3
21 Aquatic Mollusks	0	1	2	3
22 Fish	0	0.5	1	1.5
23 Crayfish	0	0.5	1	1.5
24 Amphibians	0	0.5	1	1.5
25 Algae	0	0.5	1	1.5
26 Wetland plants in streambed	FAOW = 0.75 / OBL = 1.5 / Other = 0			

^a perennial streams may also be identified using other methods. See p. 35 of manual

Notes: 20: Lots of isopods

Sketch:

201610061206

17

NC DWQ Stream Identification Form Version 4.11

Date: <u>10/6/16</u>	Project Site: <u>9789-24-7373</u>	Latitude:
Evaluator: <u>DM</u>	County:	Longitude:
Total Points: Stream is at least intermittent if ≥ 19 or perennial if ≥ 30	Stream Determination (circle one) <u>Ephemeral</u> Intermittent Perennial	Other e.g. Quad Name:

18.25

A. Geomorphology (Subtotal = 8.5)

	Absent	Weak	Moderate	Strong
1. Continuity of channel bed and bank	0	1	<u>2</u>	3
2. Sinuosity of channel along thalweg	0	1	<u>2</u>	3
3. In-channel structure ex. riffle-pool step-pool riffle-pool sequence	0	<u>1</u>	2	3
4. Particle size of stream substrate	0	<u>1</u>	2	3
5. Active/relict floodplain	<u>0</u>	1	2	3
6. Depositional bars or benches	<u>0</u>	1	2	3
7. Recent alluvial deposits	0	<u>1</u>	2	3
8. Headcuts	0	<u>1</u>	2	3
9. Grade control	0	<u>0.5</u>	1	1.5
10. Natural valley	<u>0</u>	0.5	1	1.5
11. Second or greater order channel	No = <u>0</u>		Yes = 3	

*artificial ditches are not rated, see discussions in manual

B. Hydrology (Subtotal = 4.5)

12. Presence of Baseflow	<u>0</u>	1	2	3
13. Iron oxidizing bacteria	<u>0</u>	1	2	3
14. Leaf litter	1.5	<u>1</u>	0.5	0
15. Sediment on plants or debris	<u>0</u>	0.5	1	1.5
16. Organic debris lines or piles	0	<u>0.5</u>	1	1.5
17. Soil-based evidence of high water table?	No = 0		Yes = <u>3</u>	

C. Biology (Subtotal = 5.75)

18. Fibrous roots in streambed	3	2	<u>1</u>	0
19. Rooted upland plants in streambed	<u>3</u>	2	1	0
20. Macroinvertebrates (note diversity and abundance)	<u>0</u>	1	2	3
21. Aquatic Mollusks	<u>0</u>	1	2	3
22. Fish	<u>0</u>	0.5	1	1.5
23. Crayfish	<u>0</u>	0.5	1	1.5
24. Amphibians	<u>0</u>	0.5	1	1.5
25. Algae	0	0.5	<u>1</u>	1.5
26. Wetland plants in streambed	FACW = <u>0.75</u> OBL = 1.5 Other = 0			

*perennial streams may also be identified using other methods. See p. 35 of manual.

Notes:

Sketch:

201610061210

R18

NC DWQ Stream Identification Form Version 4.11

Date: 10/6/16	Project Site: 9789-24-7373	Latitude:
Evaluator: DM	County:	Longitude:
Total Points: Stream is at least intermediate if ≥ 19 or perennial if ≥ 30	Stream Determination (circle one) Ephemeral Intermittent Perennial	Other e.g. Quad Name:

16.25

A. Geomorphology (Subtotal = 8)	Absent	Weak	Moderate	Strong
1. Continuity of channel bed and bank	0	(1)	2	3
2. Sinuosity of channel along thalweg	0	1	(2)	3
3. In-channel structure (e.g. riffle-pool, step-pool, ripple-pool sequence)	0	(1)	2	3
4. Particle size of stream substrate	0	(1)	2	3
5. Active/relict floodplain	(0)	1	2	3
6. Depositional bars or benches	0	(1)	2	3
7. Recent alluvial deposits	0	(1)	2	3
8. Headcuts	(0)	1	2	3
9. Grade control	0	0.5	(1)	1.5
10. Natural valley	(0)	0.5	1	1.5
11. Second or greater order channel		No = (2)		Yes = 3

*artificial ditches are not rated (see discussions in manual)

B. Hydrology (Subtotal = 1.5)

12. Presence of baseflow	(0)	1	2	3
13. Iron oxidizing bacteria	(0)	1	2	3
14. Leaf litter	1.5	1	(0.5)	0
15. Sediment on plants or debris	(0)	0.5	1	1.5
16. Organic debris (logs or piles)	0	0.5	(1)	1.5
17. Soil-based evidence of high water table?		No = 0		Yes = 3

C. Biology (Subtotal = 6.75)

18. Fibrous roots in streambed	3	(2)	1	0
19. Rooted upland plants in streambed	(3)	2	1	0
20. Macroinvertebrates (note diversity and abundance)	(0)	1	2	3
21. Aquatic Mollusks	(0)	1	2	3
22. Fish	(0)	0.5	1	1.5
23. Crayfish	(0)	0.5	1	1.5
24. Amphibians	(0)	0.5	1	1.5
25. Algae	0	0.5	(1)	1.5
26. Wetland plants in streambed		FAOW = (0.75)	OBL = 1.5	Other = 0

*perennial streams may also be identified using other methods. See p. 36 of manual

Notes:

Sketch:

201610061220

RIS

NC DWQ Stream Identification Form Version 4.11

Date: 10/6/2016	Project Site: 9789-24-7373	Latitude:
Evaluator: DM	County:	Longitude:
Total Points: 14.25 <small>Streams at least intermittent: 1 pt. Ephemeral: 1 pt. Intermittent: 1 pt. Perennial: 1 pt.</small>	Stream Determination (circle one): Ephemeral Intermittent Perennial	Other: e.g. Quad Name:

A. Geomorphology (Subtotal = 7.5)

	Absent	Weak	Moderate	Strong
1. Continuity of channel bed and bank	0	1	2	3
2. Sinuosity of channel along thalweg	0	1	2	3
3. In-channel structure: riffle-pool, step-pool, ripple-pool sequence	0	1	2	3
4. Particle size of stream substrate	0	1	2	3
5. Active/riffle floodplain	0	1	2	3
6. Depositional bars or benches	0	1	2	3
7. Recent alluvial deposits	0	1	2	3
8. Headcuts	0	1	2	3
9. Grade control	0	0.5	1	1.5
10. Natural valley	0	0.5	1	1.5
11. Second or greater order channel		No = 0		Yes = 3

*artificial ditches are not rated. see discussions in manual

B. Hydrology (Subtotal = 4.5)

12. Presence of Baseflow	0	1	2	3
13. Iron oxidizing bacteria	0	1	2	3
14. Leaf litter	1.5	1	0.5	0
15. Sediment on plants or debris	0	0.5	1	1.5
16. Organic debris (leaves or piles)	0	0.5	1	1.5
17. Soil-based evidence of high water table?		No = 0		Yes = 3

C. Biology (Subtotal = 2.25)

18. Fibrous roots in streambed	3	2	1	0
19. Rooted upland plants in streambed	3	2	1	0
20. Macroinvertebrates (more diversity and abundance)	0	1	2	3
21. Aquatic Mollusks	0	1	2	3
22. Fish	0	0.5	1	1.5
23. Crayfish	0	0.5	1	1.5
24. Amphibians	0	0.5	1	1.5
25. Algae	0	0.5	1	1.5
26. Wetland plants in streambed		FAC/W = 0.75	OBL = 1.5	Other = 0

*perennial streams may also be identified using other methods. See p. 35 of manual

Notes:

Sketch:

201610061226

RVI

NC DWQ Stream Identification Form Version 4.11

Date: 10/6/16	Project/Site: 9789-24-7373	Latitude:
Evaluator: DM	County:	Longitude:
Total Points: Stream is at least intermittent if ≥ 19 or perennial if $\geq 30^*$ 12.75	Stream Determination (circle one) Ephemeral Intermittent Perennial	Other e.g. Quad Name:

A. Geomorphology (Subtotal = 4.5)

	Absent	Weak	Moderate	Strong
1 ^a Continuity of channel bed and bank	0	1	2	3
2. Sinuosity of channel along thalweg	0	1	2	3
3. In-channel structure: ex. riffle-pool, step-pool, ripple-pool sequence	0	1	2	3
4. Particle size of stream substrate	0	1	2	3
5. Active/relict floodplain	0	1	2	3
6. Depositional bars or benches	0	1	2	3
7. Recent alluvial deposits	0	1	2	3
8. Headcuts	0	1	2	3
9. Grade control	0	0.5	1	1.5
10. Natural valley	0	0.5	1	1.5
11. Second or greater order channel	No = 0		Yes = 3	

^a artificial ditches are not rated; see discussions in manual

B. Hydrology (Subtotal = 2)

12. Presence of Baseflow	0	1	2	3
13. Iron oxidizing bacteria	0	1	2	3
14. Leaf litter	1.5	1	0.5	0
15. Sediment on plants or debris	0	0.5	1	1.5
16. Organic debris lines or piles	0	0.5	1	1.5
17. Soil-based evidence of high water table?	No = 0		Yes = 3	

C. Biology (Subtotal = 6.25)

18. Fibrous roots in streambed	3	2	1	0
19. Rooted upland plants in streambed	3	2	1	0
20. Macroinvertebrates (note diversity and abundance)	0	1	2	3
21. Aquatic Mollusks	0	1	2	3
22. Fish	0	0.5	1	1.5
23. Crayfish	0	0.5	1	1.5
24. Amphibians	0	0.5	1	1.5
25. Algae	0	0.5	1	1.5
26. Wetland plants in streambed	FACW = 0.75; OBL = 1.5 Other = 0			

*perennial streams may also be identified using other methods. See p. 35 of manual.

Notes:

Sketch:

201610061231

R12

NC DWQ Stream Identification Form Version 4.11

Date: 10/6/16	Project/Site: 9789-24-1373	Latitude:
Evaluator: DM	County:	Longitude:
Total Points: Stream is at least intermittent if ≥ 19 or perennial if $\geq 30^*$ 14.5	Stream Determination (circle one) Ephemeral Intermittent Perennial	Other e.g. Quad Name:

A. Geomorphology (Subtotal = 4.5)

	Absent	Weak	Moderate	Strong
1 ^a . Continuity of channel bed and bank	0	1	2	3
2. Sinuosity of channel along thalweg	0	1	2	3
3. In-channel structure: ex. riffle-pool, step-pool, ripple-pool sequence	0	1	2	3
4. Particle size of stream substrate	0	1	2	3
5. Active/relict floodplain	0	1	2	3
6. Depositional bars or benches	0	1	2	3
7. Recent alluvial deposits	0	1	2	3
8. Headcuts	0	1	2	3
9. Grade control	0	0.5	1	1.5
10. Natural valley	0	0.5	1	1.5
11. Second or greater order channel	No = 0		Yes = 3	

^a artificial ditches are not rated; see discussions in manual

B. Hydrology (Subtotal = 4)

12. Presence of Baseflow	0	1	2	3
13. Iron oxidizing bacteria	0	1	2	3
14. Leaf litter	1.5	1	0.5	0
15. Sediment on plants or debris	0	0.5	1	1.5
16. Organic debris lines or piles	0	0.5	1	1.5
17. Soil-based evidence of high water table?	No = 0		Yes = 3	

C. Biology (Subtotal = 6)

18. Fibrous roots in streambed	3	2	1	0
19. Rooted upland plants in streambed	3	2	1	0
20. Macroinvertebrates (note diversity and abundance)	0	1	2	3
21. Aquatic Mollusks	0	1	2	3
22. Fish	0	0.5	1	1.5
23. Crayfish	0	0.5	1	1.5
24. Amphibians	0	0.5	1	1.5
25. Algae	0	0.5	1	1.5
26. Wetland plants in streambed	FACW = 0.75; OBL = 1.5 Other = 0			

*perennial streams may also be identified using other methods. See p. 35 of manual.

Notes:

Sketch:

201610061235

(2.1)

NC DWQ Stream Identification Form Version 4.11

Date: 10/6/16	Project/Site: 9789-24-7373	Latitude:
Evaluator: DM	County:	Longitude:
Total Points: Stream is at least intermittent if ≥ 19 or perennial if $\geq 30^*$ 12.75	Stream Determination (circle one) Ephemeral Intermittent Perennial	Other e.g. Quad Name:

A. Geomorphology (Subtotal = 4.5)

	Absent	Weak	Moderate	Strong
1 ^a . Continuity of channel bed and bank	0	1	2	3
2. Sinuosity of channel along thalweg	0	1	2	3
3. In-channel structure: ex. riffle-pool, step-pool, ripple-pool sequence	0	1	2	3
4. Particle size of stream substrate	0	1	2	3
5. Active/relict floodplain	0	1	2	3
6. Depositional bars or benches	0	1	2	3
7. Recent alluvial deposits	0	1	2	3
8. Headcuts	0	1	2	3
9. Grade control	0	0.5	1	1.5
10. Natural valley	0	0.5	1	1.5
11. Second or greater order channel	No = 0		Yes = 3	

^a artificial ditches are not rated; see discussions in manual

B. Hydrology (Subtotal = 4)

12. Presence of Baseflow	0	1	2	3
13. Iron oxidizing bacteria	0	1	2	3
14. Leaf litter	1.5	1	0.5	0
15. Sediment on plants or debris	0	0.5	1	1.5
16. Organic debris lines or piles	0	0.5	1	1.5
17. Soil-based evidence of high water table?	No = 0		Yes = 3	

C. Biology (Subtotal = 4.25)

18. Fibrous roots in streambed	3	2	1	0
19. Rooted upland plants in streambed	3	2	1	0
20. Macroinvertebrates (note diversity and abundance)	0	1	2	3
21. Aquatic Mollusks	0	1	2	3
22. Fish	0	0.5	1	1.5
23. Crayfish	0	0.5	1	1.5
24. Amphibians	0	0.5	1	1.5
25. Algae	0	0.5	1	1.5
26. Wetland plants in streambed	FACW = 0.75, OBL = 1.5 Other = 0			

*perennial streams may also be identified using other methods. See p. 35 of manual.

Notes:

Sketch:

2 0610 06 1245

12.2

Ditch

NC DWQ Stream Identification Form Version 4.11

Date: 10/6/16	Project/Site:	Latitude:
Evaluator: DM	County:	Longitude:
Total Points: Stream is at least intermittent if ≥ 19 or perennial if $\geq 30^*$ 13.5	Stream Determination (circle one) Ephemeral Intermittent Perennial	Other e.g. Quad Name:

A. Geomorphology (Subtotal = 2)

	Absent	Weak	Moderate	Strong
1 ^a Continuity of channel bed and bank	0	1	2	3
2. Sinuosity of channel along thalweg	0	1	2	3
3. In-channel structure: ex. riffle-pool, step-pool, ripple-pool sequence	0	1	2	3
4. Particle size of stream substrate	0	1	2	3
5. Active/relict floodplain	0	1	2	3
6. Depositional bars or benches	0	1	2	3
7. Recent alluvial deposits	0	1	2	3
8. Headcuts	0	1	2	3
9. Grade control	0	0.5	1	1.5
10. Natural valley	0	0.5	1	1.5
11. Second or greater order channel	No = 0		Yes = 3	

^a artificial ditches are not rated; see discussions in manual

B. Hydrology (Subtotal = 5.5)

12. Presence of Baseflow	0	1	2	3
13. Iron oxidizing bacteria	0	1	2	3
14. Leaf litter	1.5	1	0.5	0
15. Sediment on plants or debris	0	0.5	1	1.5
16. Organic debris lines or piles	0	0.5	1	1.5
17. Soil-based evidence of high water table?	No = 0		Yes = 3	

C. Biology (Subtotal = 6)

18. Fibrous roots in streambed	3	2	1	0
19. Rooted upland plants in streambed	3	2	1	0
20. Macroinvertebrates (note diversity and abundance)	0	1	2	3
21. Aquatic Mollusks	0	1	2	3
22. Fish	0	0.5	1	1.5
23. Crayfish	0	0.5	1	1.5
24. Amphibians	0	0.5	1	1.5
25. Algae	0	0.5	1	1.5
26. Wetland plants in streambed	FACW = 0.75; OBL = 1.5 Other = 0			

*perennial streams may also be identified using other methods. See p. 35 of manual.

Notes:

Sketch:



**PUBLIC WORKS DEPARTMENT
STORMWATER MANAGEMENT DIVISION**

405 Martin Luther King, Jr. Blvd.
Chapel Hill, NC 27514-5705
Telephone (919) 969-7246
Fax (919) 969-7276
www.townofchapelhill.org

REQUEST FOR STREAM DETERMINATION

Stream determinations are used to determine whether the Resource Conservation District or the Jordan Stream Buffer will apply to a property, and the areas protected if that is the case. There is no fee for stream determinations. By default, we will search records and notify you if a site visit is not needed for a property.

Check here if you want Town staff to conduct a stream determination. A new site visit may not be needed if a determination has been done in the last five years. Turnaround time is within two weeks for single-family lots depending on weather conditions, staff availability, and size of the lots.

Requests may be emailed (DMilkereit@townofchapelhill.org), faxed, dropped off at Town Hall or the Stormwater Office, or mailed to the above address care of "Stormwater Specialist".

Requestor's Name: Dewberry

Mailing Address: 2610 Wycliff Road, Suite 410

City, State, ZIP: Raleigh, NC 27607

Phone / FAX / Email: 919-424-3767/choffman@dewberry.com

Check method(s) for report to be sent:

US Mail

Email

FAX

Call for pickup

Signature of property owner or designated legal agent granting permission to Town Staff to enter the property(ies) indicated below for purposes of a Stream Determination:

(Signature)

(Date)

Owner Name(s):

(Please print)

Property Information	
fill in both columns, <u>or</u> fill in Parcel ID Number (PIN) and attach a site map indicating location	
Parcel ID Number (PIN)	Address / Location Description
Western Portion 9789247373	101 Airport Road/Estes Drive Extension

Where the total area of the property(ies) to visit is over 3 acres please attach an as-built drawing or a topographic map with current landmarks.

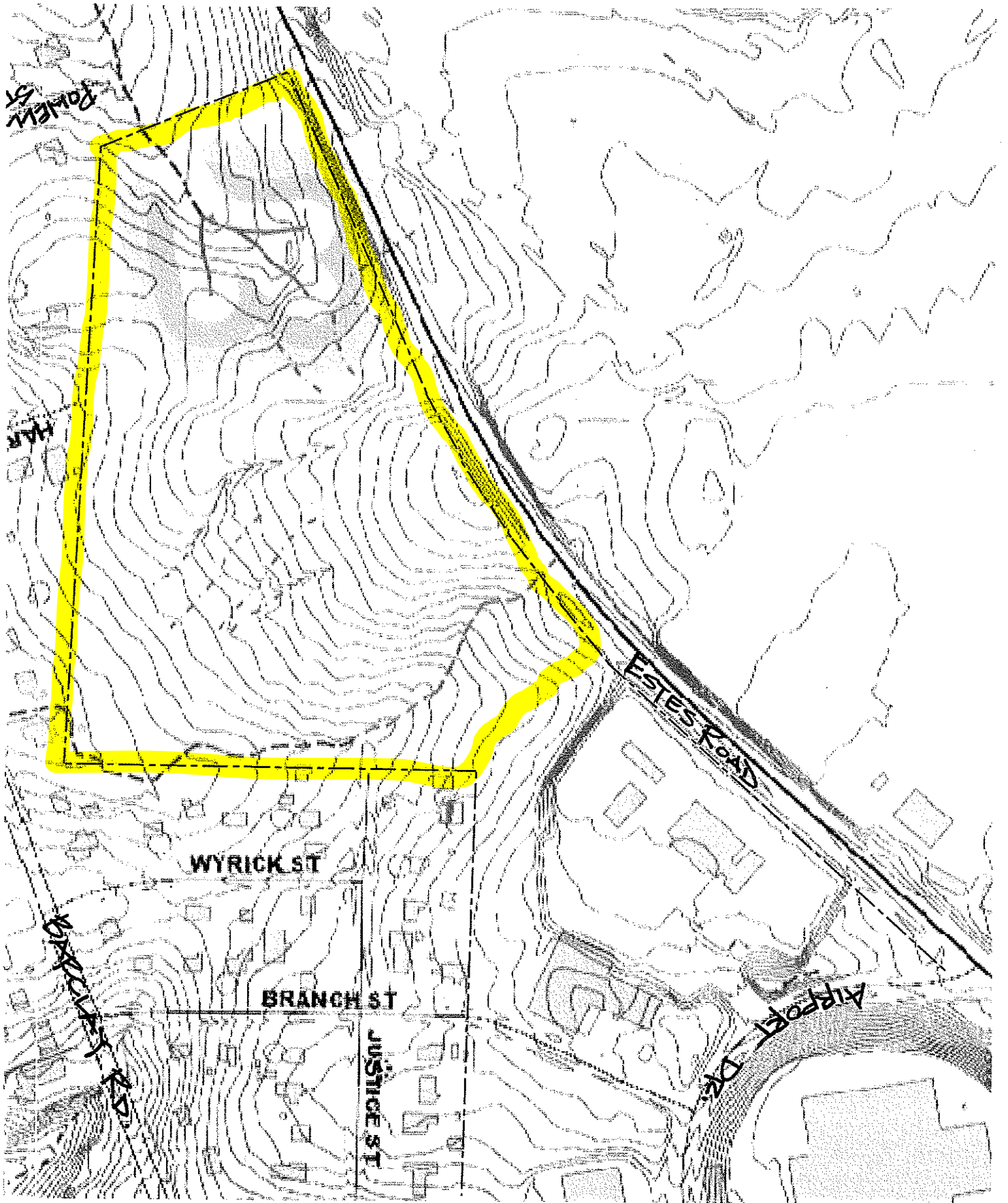

Exhibit K - Impact Analysis on the Value of Contiguous Properties of a Proposed Municipal Services Center

IMPACT ANALYSIS

ON THE VALUE OF CONTIGUOUS PROPERTIES OF
A PROPOSED MUNICIPAL SERVICES CENTER

LOCATED ON

ESTES DRIVE
CHAPEL HILL, NORTH CAROLINA

AS OF

APRIL 2, 2018

FOR

TOWN OF CHAPEL HILL
405 MARTIN LUTHER KING, JR. BOULEVARD
CHAPEL HILL, NC 27514

BY

DAVID A SMITH, MAI, SRA
POST OFFICE BOX 51597
DURHAM, NORTH CAROLINA 27717-1597

PART ONE - INTRODUCTION



DAVID A. SMITH, MAI, SRA

P.O. BOX 51597
DURHAM, NORTH CAROLINA 27717-1597
PHONE (919) 493-1534
smithappraiser@verizon.net



April 3, 2018

Town of Chapel Hill
405 Martin Luther King, Jr. Boulevard
Chapel Hill, NC 27514

As requested, I have inspected the properties contiguous to a proposed municipal services center to be located on Estes Drive in Chapel Hill, North Carolina.

The purpose of this analysis is to determine if a proposed municipal services center is “located, designed, and proposed to be operated so as to maintain or enhance the value of contiguous property.” The intended use of this report is to assist the approving body in determining the effect of the proposed municipal services center. The intended users of this report are officers and employees of the Town of Chapel Hill and anyone they designate.

As requested, a summary report has been prepared. This is not an appraisal, but a consulting assignment.

The property was last inspected on April 2, 2018 which is the effective date of this report and analysis. Based on an inspection of the property and the contiguous properties, an analysis of data gathered and facts and conclusions as contained in the following report of 17 pages, and subject to the assumptions and limiting conditions as stated, it is my opinion that the **proposed municipal services center will maintain or enhance the value of contiguous property.**

I certify that I have personally inspected the property and the contiguous properties. I further certify that I have no interest either present or contemplated in the properties and that neither the employment to make this analysis nor the compensation is contingent upon the result of the analysis.

Respectfully submitted,

David A. Smith

David A. Smith, MAI, SRA
NC State-Certified General Real Estate Appraiser #A281



TABLE OF CONTENTS

	PAGE
PART ONE-INTRODUCTION	
Letter of Transmittal	1
Table of Contents	2
Certification of Value	3
PART TWO-PREMISES OF THE APPRAISAL	
Statement of Competence	4
Extraordinary Assumptions and Hypothetical Conditions	4
General Assumptions and Limiting Conditions	4
Purpose and Intended Use of the Report	5
Definition of Value	5
Date of Analysis and Date of Report	6
Property Rights	6
Scope of Work	7
PART THREE-PRESENTATION OF DATA	
Description of Property	8
Contiguous Properties	9
PART FOUR-ANALYSIS OF DATA AND CONCLUSIONS	
Effect of the Proposed Municipal Services Center	11
Conclusion and Summary	12
Qualifications of the Appraiser	13
ADDENDA	
Photographs	
Flood Topo Map	
Aerial Map	
Plat	

CERTIFICATION

I certify that, to the best of my knowledge and belief,...

The statements of fact contained in this report are true and correct.

The reported analyses, opinions, and conclusions are limited only by the reported assumptions and limiting conditions, and are my personal, impartial, and unbiased professional analyses, opinions, and conclusions.

I have no present or prospective interest in the property that is the subject of this report, and no personal interest with respect to the parties involved.

I have no bias with respect to the property that is the subject of this report or to the parties involved with this assignment.

My engagement in this assignment was not contingent upon developing or reporting predetermined results.

My compensation for completing this assignment is not contingent upon the development or reporting of a predetermined value or direction in value that favors the cause of the client, the amount of the value opinion, the attainment of a stipulated result, or the occurrence of a subsequent event directly related to the intended use of this appraisal.

My analyses, opinions, and conclusions were developed, and this report has been prepared, in conformity with the *Uniform Standards of Professional Appraisal Practice*.

I have made a personal inspection of the property that is the subject of this report.

No one provided significant real property appraisal assistance to the person signing this certification.

The reported analysis, opinions, and conclusions were developed, and this report has been prepared, in conformity with the requirements of the Code of Professional Ethics and the Standards of Professional Appraisal Practice of the Appraisal Institute.

The use of this report is subject to the requirements of the Appraisal Institute relating to review by its duly authorized representatives.

As of the date of the report, I have completed the requirements of the continuing education program of the Appraisal Institute.

This assignment was not made, nor was the appraisal rendered on the basis of a requested minimum valuation, specific valuation, or an amount, which would result in approval of a credit transaction.

David A. Smith

David A. Smith, MAI, SRA

PART TWO – PREMISES OF THE REPORT

STATEMENT OF COMPETENCE

I have completed all of the requirements to become a state certified-general appraiser for the State of North Carolina and all of the requirements for the MAI designation. In addition I have successfully completed USPAP courses and continuing education seminars for over thirty years. More detailed information about these courses and seminars are in the qualifications section of this report. I have prepared similar analyses and feel competent to perform this analysis.

EXTRAORDINARY ASSUMPTIONS AND HYPOTHETICAL CONDITIONS

An extraordinary assumption is an assumption, directly related to a specific assignment, which if found to be false, could alter the appraiser's opinions or conclusions. A hypothetical condition is something that is contrary to what exists but is supposed for the purpose of the analysis. This analysis assumes that the property will be improved with the municipal services center as planned. No other extraordinary assumptions or hypothetical conditions are made.

GENERAL ASSUMPTIONS AND LIMITING CONDITIONS

The report has been made with the following general assumptions:

1. Possession of this report, or a copy thereof, does not carry with it the right of publication.
2. The appraiser by reason of this report is not required to give further consultation or testimony or to be in attendance in court with reference to the property in question unless arrangements have been previously made.
3. Neither all nor any part of the contents of this report (especially any conclusions, the identity of the appraiser, or the firm with which the appraiser is connected) shall be disseminated to the

public through advertising, public relations, news, sales or other media without the prior written consent and approval of the appraiser.

4. Definitions used in this report have been taken from *The Dictionary of Real Estate Appraisal*, 5th ed., published by the Appraisal Institute, copyright 2010.

5. Descriptions of the site and proposed improvements is based on a personal inspection of the property, public records and information supplied by the Town of Chapel Hill. This includes a set of plans entitled “Town of Chapel Hill, Municipal Services Building, Site and Building Design” dated February 22, 2018. For purposes of this report this information is assumed to be correct. Copies of these plans are in the addenda.

PURPOSE, INTENDED USE AND USERS OF THE REPORT

The purpose of this analysis is to determine if a proposed municipal service center will maintain or enhance the value of contiguous properties. The intended use of the appraisal is to assist the approving body in determining the effect of the proposed center. The intended users of this report are offices and employees of the Town of Chapel Hill and anyone they designate.

DEFINITION OF VALUE

The opinion of value in this appraisal is the market value. The definition of market value is that used by federally regulated financial institutions

The most probable price which a property should bring in a competitive and open market under all conditions requisite to a fair sale, the buyer and seller each acting prudently and knowledgeably, and assuming the price is not affected by undue stimulus. Implicit in this definition is the consummation of a sale as of a specified date and the passing of title from seller to buyer under conditions whereby:

1. buyer and seller are typically motivated;
2. both parties are well informed or well advised, and acting in what they consider their own best interests;
3. a reasonable time is allowed for exposure in the open market;
4. payment is made in terms of cash in United States dollars or in terms of financial arrangements comparable thereto; and
5. the price represents the normal consideration for the property sold unaffected by special or creative financing or sales concessions granted by anyone associated with the sale.

DATE OF ANALYSIS AND DATE OF REPORT

The effective date of the analysis is April 2, 2018. The date of the report is April 3, 2018.

PROPERTY RIGHTS

The ownership interest considered in this report is the fee simple interest. The contiguous properties may be leased or have other property rights transferred, but the effect is for the fee simple value of the properties. The definition of fee simple as used in this report is:

Absolute ownership unencumbered by any other interest or estate, subject only to the limitations imposed by the governmental powers of taxation, eminent domain, police power, and escheat.

SCOPE OF WORK

The scope of the report involves collection and confirmation of data relative to the municipal services center property and the contiguous properties. I inspected the property and the plans provided and observed the contiguous properties from the street right-of-ways. I performed an analysis based on properties that are contiguous to an existing municipal facility to determine the effect on other properties. From this information, I determined that the proposed use will maintain or enhance the value of contiguous properties.

PART THREE – PRESENTATION OF DATA

DESCRIPTION OF PROPERTY

Since the purpose of this report is to determine the effect of the proposed municipal services center on contiguous properties and not the property where the center will be located, only a brief description of the municipal services center property is given. It consists of two parcels with tax IDs of 9789-03-3163 and 9789-24-7373. The first parcel is owned by the University of North Carolina Endowment Fund Trustees, contains 2.5 acres and is heavily wooded. The second is owned by the University of North Carolina and contains 59.33 acres. The eastern section of this parcel is improved with facilities for the University of North Carolina but the western area where the proposed municipal services center will be located is unimproved and heavily wooded.

The property is located on the south side of Estes Drive a short distance north of the Estes /Seawell School Road intersection. Four roads dead end into the property, Justice Street, Hartig Street, Powell Street and Ward Street. Traffic would enter and leave the site at two points on Estes Drive roughly in the middle of the site.

The building will be three and a half stories in height and contain about 72,000 square feet of enclosed area. The exterior walls will be mostly glass. There will be several paved surface parking lots with a total of 285 to 330 spaces.

The land will be leased to the Town by the University. Uses on the property include: Police Headquarters, Fire Administration, Parks and Recreation Administration and other small town functions (wellness clinic, ombud, etc). The police will leave the property at 6 pm and the patrol is out in the community until 6 am. The building is not occupied 24/7 although there may occasionally be an individual officer or cleaning service on site.

The Town plans to pursue LEED designation for the Municipal Services Center and has committed to minimum light, sound, noise pollution through building design, technology, and the preservation of existing perimeter vegetation as well as additional landscaping around the disturbed area of the site.

The Town will also build a storm water treatment system. Currently, storm water is unmanaged and exits the property in the southeastern corner occasionally flooding the residential properties in that location. Post-development storm water runoff cannot exceed pre-development runoff and might actually be mitigated or improved.

Future facilities could include: A UNC building with similar office/administrative uses, a smaller town or university building with similar uses, or a fire station on the western end of the site with access to Estes Drive.

Copies of the site plan, tax cards, zoning map, aerial, floodplain map of the property from the GIS records are in the addenda. Photos of the property are also in the addenda.

CONTIGUOUS PROPERTIES

The proposed municipal services center is located in Orange County and in the city limits of Chapel Hill. The property is located on the south side of Estes Road across the street from the Chapel Hill Airport. Some of the site is part of a larger parcel and only those properties that adjoin that portion of the parcel where the center will be constructed are considered.

There are sixteen properties that will be contiguous to the proposed municipal services center. I did not enter any of the buildings but observed them all from the street. All are improved with single family dwellings. The following information is from tax records. One of the dwellings was built in 2002 but the rest were constructed between 1941 and 1962. One is 2,026 square feet in size but the rest range from 700 to 1,728 square feet in size. The average age is 67 years and the average size is 1,099 square feet. All of the properties appear to be in good condition and the neighborhood is a stable middle class one. The dwellings are occupied by a mixture of owners and tenants. A chart of the contiguous properties is on the following page. Photographs of some of the dwellings are in the addenda.

DAVID A. SMITH, MAI, SRA

Pin	Address	Size	Land Value	Building Value	Total Value	Year Built	Building Size
9789123934	804 Hartig St	0.28	\$100,000	\$172,000	\$272,000	1954	2,026
9789022908	832 Ward St	0.47	\$100,000	\$124,100	\$224,100	1956	1,333
9789027973	8 Powell St	0.72	\$100,000	\$112,100	\$212,100	1962	1,148
9789120930	805 Hartig St	0.81	\$100,000	\$154,300	\$254,300	1941	1,456
9789125836	224 Barclay Rd	0.37	\$100,000	\$88,400	\$188,400	1942	806
9789125899	222 Barclay Rd	0.31	\$100,000	\$102,200	\$202,200	1942	962
9789126980	220 Barclay Rd	0.31	\$100,000	\$125,800	\$225,800	1947	1,385
9789127981	218 Barclay Rd	0.21	\$100,000	\$126,800	\$226,800	1955	1,401
9789128969	216 Barclay Rd	0.46	\$100,000	\$92,200	\$192,200	1942	800
9789139112	1 Wyrick St	0.31	\$100,000	\$77,200	\$177,200	1947	768
9789139128	4 Wyrick St	0.3	\$100,000	\$47,000	\$147,000	1947	750
9789138295	807 Wyrick St	0.3	\$100,000	\$79,800	\$179,800	1947	775
9789138599	208 Justice St	0.5	\$100,000	\$163,300	\$263,300	2002	1,728
9789139599	206 Justice St	0.31	\$100,000	\$74,000	\$174,000	1942	700
9789230579	204 Justice St	0.33	\$100,000	\$100,900	\$200,900	1942	850
9789138357	211 Justice St	0.22	\$100,000	\$39,000	\$139,000	1952	700

PART FOUR – ANALYSIS OF DATA AND CONCLUSIONS

EFFECT OF THE PROPOSED MUNICIPAL SERVICES CENTER

The potential adverse effects from any proposed use are environmental hazards, odor, noise, lighting, traffic and visual impact. Based on the information supplied, there will be no environmental hazards or increased odor associated with the proposed use. Lighting and visual impact will be minor and not more than a typical office building which is currently allowed without further approval. Traffic and noise should also not be higher than if the building was used as an office building. Police leave at 6 pm and do not return until 6am. There will be no direct access between the center and the adjacent neighborhood.

In order to estimate the effect of the proposed municipal services center on contiguous properties, I researched sales of dwellings in close proximity to existing municipal facilities. A short distance to the east of the proposed center are similar facilities for UNC. These facilities are contiguous to properties along the north side of Justice Street. I located three contiguous properties on Justice Street and compared them with four properties on the south side of Justice Street that are not contiguous to the facilities. The properties are similar in most respects. I only considered properties that sold since 2010 and were built between 1942 and 1955. I adjusted them for differences in market conditions (time) and divided the result by the square footage of the dwellings. A chart showing these properties is on the following page.

The three properties on the north side of Justice Street (contiguous to the municipal facilities) give an average adjusted selling price of \$191.44 per square foot. Those on the south side (not contiguous to the facilities) give an average adjusted selling price of \$187.07 per square foot or about 2.00% less. That is the properties that are contiguous to the municipal facilities actually sold for more. However, this is a very small difference and is within the margin of error.

Pin	Address	Land Size	Date Sold	Sales Price	Year Built	Build Sq Ft	Market Condition	Adjusted
CONTIGUOUS TO MUNICIPAL FACILITIES								
9789230579	204 Justice	0.33	6/13/2012	\$ 175,000	1942	850	14.51%	\$235.76
9789234596	134 Justice	0.31	12/21/2015	\$ 299,500	1948	1790	5.71%	\$176.86
9789239576	120 Justice	0.32	12/12/2010	\$ 295,000	1955	2158	18.27%	\$161.68
							Average	\$191.44
NOT CONTIGUOUS TO MUNICIPAL FACILITIES								
9789234307	135 Justice	0.31	10/27/2014	\$ 158,000	1942	1216	8.58%	\$141.09
9789235358	131 Justice	0.31	8/10/2017	\$ 342,000	1942	2064	1.61%	\$168.36
9789236326	129 Justice	0.31	7/30/2012	\$ 165,000	1942	1121	14.19%	\$168.08
9789239434	123 Justice	0.33	7/25/2013	\$ 190,000	1942	784	11.73%	\$270.76
							Average	\$187.07

CONCLUSION AND SUMMARY

To determine if the proposed municipal services center will maintain or enhance the value of contiguous property, I considered properties near the proposed center that are currently contiguous to similar municipal facilities. I compared properties contiguous to these facilities with those that are not contiguous and found little difference in the selling prices. Based on this it is my opinion that the proposed municipal services center will not adversely affect the property values of those dwellings that will be contiguous to the center and the proposed use will maintain the value of the contiguous property.



DAVID A. SMITH, MAI, SRA

DAVID A SMITH & ASSOCIATES, INC.
P.O. BOX 51597
DURHAM, NORTH CAROLINA 27717-1597
PHONE (919) 493-1534
smithappraiser@frontier.com



QUALIFICATIONS OF DAVID A. SMITH, MAI, SRA

The appraiser, David A. Smith, has been involved in the appraisal of real estate for over thirty years. He worked with his father, Charles W. Smith, from 1976 to 2003. After the retirement of Charles W. Smith in 2003 he formed Smith & Whitfield, Inc. and later David A. Smith & Associates. In 1988 he was awarded the RM designation. With the merger of the American Institute of Real Estate Appraisers and the Society of Real Estate Appraisers in January of 1991, the RM designation was changed to the SRA designation. In 1991 he was awarded the MAI designation of the Appraisal Institute. He became a state-certified real estate appraiser in 1991 the year the state first began licensing real estate appraisers and his certification number is A281.

He has also trained and supervised several appraisers and has prepared all types of appraisal reports. His primary focus is Durham County and the adjoining counties of Orange, Person, Granville and Chatham.

EDUCATION: Graduate Episcopal High School, Alexandria, VA, 1976
A.B., Duke University, Durham, NC, 1981

APPRAISAL INSTITUTE COURSES:

Real Estate Appraisal Principles (Exam 1A-1/8-1), University of North Carolina, 1981
Residential Valuation (Exam 8-2), University of North Carolina, 1981
Basic Valuation Procedures (Exam 1A-2), University of North Carolina, 1983
Standards of Professional Practice (Exam SPP), University of North Carolina, 1983
Capitalization Theory & Techniques, A (Exam 1B-A), University of Colorado, 1984
Capitalization Theory & Techniques, B (Exam 1B-B), University of Colorado, 1984
Valuation Analysis and Report Writing (Exam 2-2), University of North Carolina, 1987
Case Studies in Real Estate Valuation (Exam 2-1), University of North Carolina, 1987
Advanced Sales Comparison & Cost Approaches, Atlanta, Georgia, 2002
General Appraiser Market Analysis and Highest and Best Use, Atlanta, Georgia, 2007
Online Business Practices and Ethics, Chicago, Illinois, 2007
Appraisal Curriculum Overview, 2009
Condemnation Appraising: Principles & Applications, Greensboro, NC, 2011

APPRAISAL INSTITUTE SEMINARS:

Highest and Best Use, 1988
Industrial Valuation, 1988
Rates, Ratios and Reasonableness, 1988
Valuation of Leased Fee Interests, 1989
Current Problems in Industrial Valuation, 1989
Methods of Subdivision Analysis, 1989
Expert Witness in Litigation, 1989
Discounted Cash Flow, 1990
RTC Appraisal Standards, 1990
Preparation and Use of the UCIAR Form, 1990
Standards of Professional Practice Update, 1990
Commercial Construction Overview, 1991
Appraising Troubled Properties, 1991
Appraisal Regulations of the Federal Banking Agency, 1992
Real Estate Law for Appraisals, 1992
Appraising Apartments, 1993
Discounted Cash Flow Analysis, 1994
Appraiser's Legal Liabilities, 1994
Understanding Limited Appraisals, 1994
Analysis Operating Expenses, 1995
Future of Appraisals, 1996
Highest and Best Use Applications, 1996
Standards of Professional Practice, Parts A & B, 1997
Litigation Skills for the Appraiser, 1997
Eminent Domain & Condemnation Appraising, 1998
Matched Pairs/Highest & Best Use/Revisiting Report Options, 1998
Valuation of Detrimental Conditions, 1998
Appraisal of Nonconforming Uses, 2000
How GIS Can Help Appraisers Keep Pace with Changes in R E Industry, 2001
Feasibility Analysis, Market Value and Investment Timing, 2002
Analyzing Commercial Lease Clauses, 2002
Standards of Professional Appraisal Practice, 2002
Effective Appraisal Writing, 2003
Supporting Capitalization Rates, 2004
National USPAP Update, 2004
Rates and Ratios: Making Sense of GIMs, OARs, and DCFs, 2005
The Road Less Traveled: Special Purpose Properties, 2005
National USPAP Update, 2006
Appraisal Consulting: A Solutions Approach for Professionals, 2006
What Clients Would Like Their Appraisers to Know, 2007
Valuation of Detrimental Conditions, 2007
Business Practice and Ethics, 2007
Office Building Valuation: A Contemporary Perspective, 2008
Subdivision Valuation, 2008
National USPAP Update, 2009
Effective Appraisal Writing, 2009
Appraisal Curriculum Overview, 2009
Discounted Cash Flow Model: Concepts, Issues and Apps., 2010
National USPAP Update, 2010

Rates and Ratios: Making sense of GIMs, OARs and DCFs, 2011
National USPAP Update, 2012
Business Practices and Ethics, 2012
Marketability Studies: Advanced Considerations & Applications, 2013
Real Estate Valuation Conference, 2013
National USPAP Update, 2014

OTHER SEMINARS:

Commercial Segregated Cost Seminar, Marshall & Swift, 1988
Appraisal Guide and Legal Principles, Department of Transportation, 1993
The Grammar Game, Career Track, 1994

MEMBERSHIPS:

Appraisal Institute, MAI #09090
Appraisal Institute, SRA/RM #2248
Durham Board of Realtors
North Carolina Association of Realtors
National Association of Realtors

CERTIFICATION:

State Certified General Real Estate Appraiser for North Carolina, #A281

OTHER:

NC Property Tax Commission, 2013 – Present
Durham Civilian Police Review Board, 2009 - Present, Past Chair
Durham County Board of Equalization and Review, 2013 – Present
Durham Public Schools Budget Advisory Committee, 2013 - Present
City of Durham Audit Oversight Committee, 2002 – 2006
Durham Board of Adjustment, 1994 - 2002
Durham City/County Zoning Commission, 1990 – 1995
John Avery Boys and Girls Club, 1994-2002
Historical Preservation Society, 1992 - 1995
Vice President of the Candidates, 1989, NC Chapter 40
President of the Candidates, 1990, NC Chapter 40
Candidate of the Year, 1990, NC Chapter 40

RECENT CLIENTS (within the past five years):

LENDING INSTITUTIONS
American National Bank & Trust Company
AMEX Financial
BB&T

Citizens National Bank
CommunityOne Bank NA
Fidelity Bank
First South Bank
Harrington Bank
KeySource Commercial Bank
Live Oak Banking Company
Mechanics & Farmers Bank
Pacific International Bank
PNC Bank
RBC Bank
Self-Help
State Farm Bank
SunTrust Bank
Wells Fargo Bank

MUNICIPALITIES AND OTHER GOVERNMENT AGENCIES

Chapel Hill Transit
City of Durham
NC Department of Administration
Durham County
Durham Public Schools
Durham Technical Community College
Housing Authority of the City of Durham
NCDOT
Orange County
Orange Water and Sewer Authority
Person County
Town of Chapel Hill

OTHER

Allenton Management
AND Associates
Barcosnic
Builders of Hope
BCG Properties
Blanchard, Miller, Lewis & Styers Attorneys at Law
Blue Cross & Blue Shield of NC
Boulevard Proeprties
Bugg & Wolf Attorneys at Law
Carolina Land Acquisitions
CRC Health Corporation
Development Ventures Inc.
Duke Energy
Durham Academy
Durham Rescue Mission
Durham Technical Community College
Edward Jones Trust Company
Farrington Road Baptist Church

Forest History Society
GBS Properties of Durham, LLC
Hayden Stanziale
Georgia Towers, LLC
Hawthorne Retail Partners
Integral
Investors Title Insurance
IUKA Development
Joelepa Associates LP
John and Mary Hebrank
LCFCU Financial Partners
Manor Associates
McDonald's USA
Mt. Gilead Baptist Church
Northgate Realty, LLC
Property Advisory Services, Inc.
Rand Enterprises
Research Triangle Foundation
Sehed Development Corporation
Simba Management
Southwest Durham Partners, LLC
Stirling Bridge Group, LLC
Styers, Kemeraite & Mitchell, PLLC
Talbert & Bright Attorneys at Law
Teer Associates
Thalle Construction
The Bogey Group
TKTK Accountants
Treyburn Corporate Park, LLC
Trinity Properties
UNC Hospitals
Voyager Academy
Wilhekan Associates

In addition, Mr. Smith has made appraisals for other lending institutions, municipalities, individuals, corporations, estates and attorneys. Appraisal assignments have been made throughout the Triangle, North Carolina, and South Carolina.

Properties appraised include all types of single family residential, multi-family residential, office, retail, commercial, industrial, churches, schools and other specialty type uses, vacant and improved, existing and proposed.

Appraisal assignments were for a variety of purposes including: mortgage loans, estate planning, condemnation, bankruptcy and equitable distribution.

ADDENDA

PHOTOGRAPHS OF SUBJECT



Street Scene along Estes Drive



Street Scene along Estes Drive

PHOTOGRAPHS OF SUBJECT



Hartig Street Dead End into Property



805 Hartig Street

PHOTOGRAPHS OF SUBJECT



804 Hartig Street



Powell Street Dead End into Property

PHOTOGRAPHS OF SUBJECT



819 Powell Street



820 Powell Street

PHOTOGRAPHS OF SUBJECT



Ward Street Dead End



832 Ward Street

PHOTOGRAPHS OF SUBJECT



Justice Street Dead End into Property



211 Justice Street

PHOTOGRAPHS OF SUBJECT



200 Justice Street



Municipal Buildings Contiguous to Justice Street

PHOTOGRAPHS OF SUBJECT



Municipal Building Contiguous to Justice Street



Municipal Building Contiguous to Justice Street

PHOTOGRAPHS OF SUBJECT



Justice Street Property Seen from Contiguous Parking Lot



Justice Street Property Seen from Contiguous Parking Lot

Aerial Map

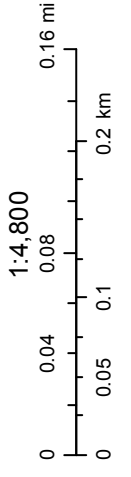

April 2, 2018

Zoning Map

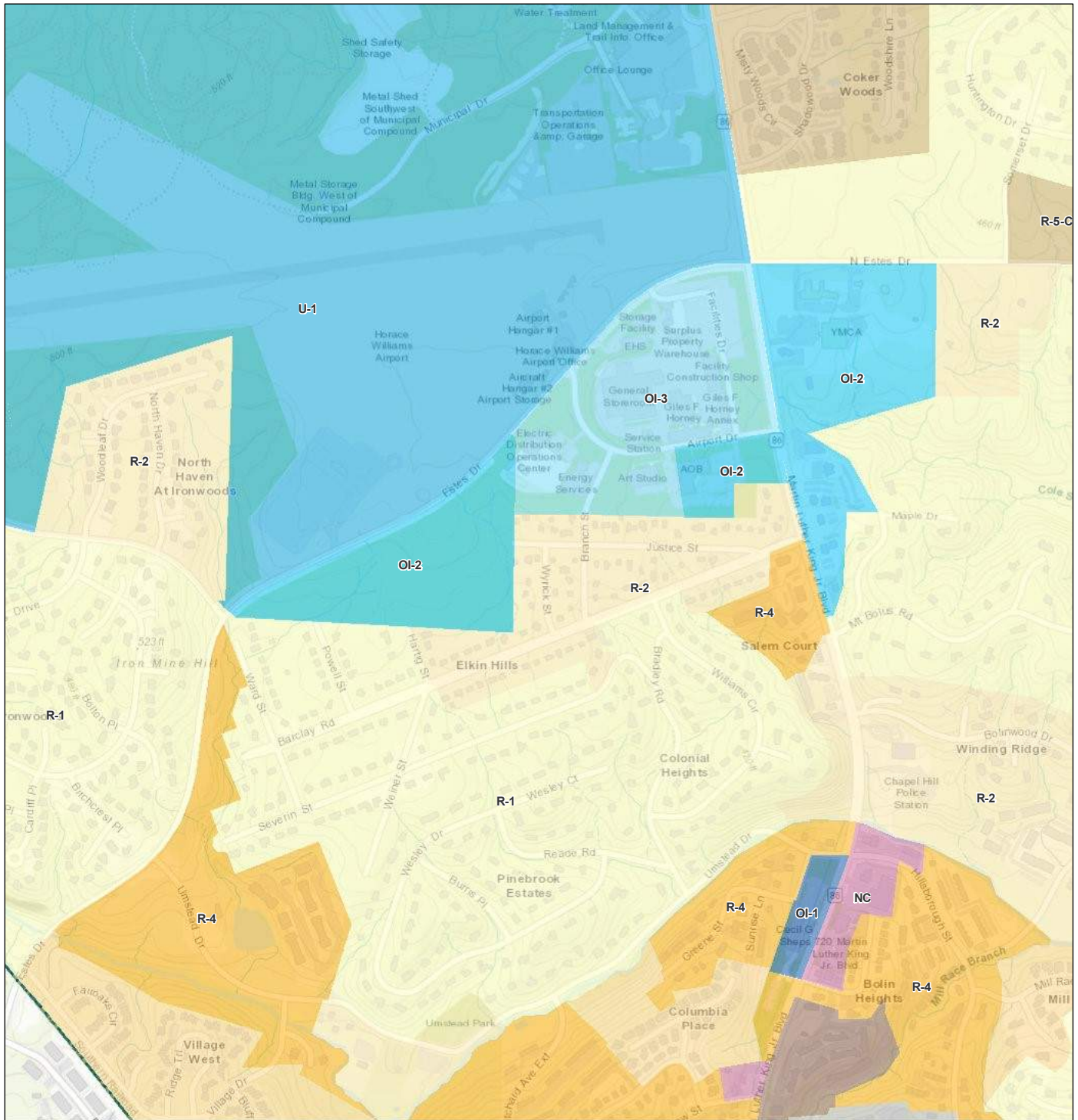

4 / 2 / 2018 10 : 52 : 16 AM

1:9,028

- Chapel Hill Jurisdictional Limits
- Chapel Hill Urban Service Area
- Chapel Hill Corporate Limits

Zoning Districts

- R-1 - Residential 1, 3 units/acre
- R-2 - Residential 2, 4 units/acre
- R-3 - Medium Density Residential, 7 units/acre
- R-4 - Medium Density Residential, 10 units/acre
- R-5 - High Density Residential, 15 units/acre
- R-5-C - High Density Residential Conditional, 15 units/acre
- R-6 - High Density Residential, 15 units/acre
- R-SS-C - Residential Special Standards Conditional
- OI-1 - Office and Institutional 1

- OI-2 - Office and Institutional 2
- OI-3 - Office and Institutional 3
- U-1 - University 1
- NC - Neighborhood Commercial

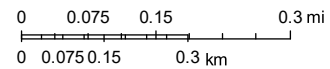

Sources: Esri, HERE, Garmin, Intermap, increment P Corp., GEBCO, USGS, FAO, NPS, NRCAN, GeoBase, IGN, Kadaster NL, Ordnance Survey, Esri Japan, METI, Esri China (Hong Kong), swisstopo, © OpenStreetMap contributors, and the GIS User Community

GIS/Tax Data



This map contains parcels prepared for the inventory of real property within Orange County, and is compiled from recorded deed, plats, and other public records and data. Users of this map are hereby notified that the aforementioned public primary information sources should be consulted for verification of the information contained on this map. The county and its mapping companies assume no legal responsibility for the information on this map.

April 2, 2018

PIN: 9789033163
OWNER 1: UNIVERSITY OF N C ENDOWMENT FUND TRUSTS 446544
OWNER 2:
ADDRESS 1: ENDOWMENT FUND TRUSTEES
ADDRESS 2:
CITY: CHAPEL HILL
STATE, ZIP: NC 27514
LEGAL DESC: S/S SR 1780

SIZE: 2.5 A
DEED REF: 446544
RATECODE: 22
DATE SOLD: 12/14/1984
BLDG SQFT:
YEAR BUILT:

BUILDING COUNT:
LAND VALUE: \$0
BLDG_VALUE: \$0
USE VALUE: \$0
TOTAL VALUE: \$0

1:4,800

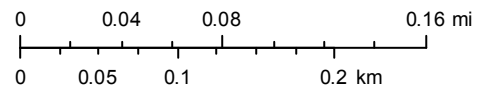

Tax/GIS Map



This map contains parcels prepared for the inventory of real property within Orange County, and is compiled from recorded deed, plats, and other public records and data. Users of this map are hereby notified that the aforementioned public primary information sources should be consulted for verification of the information contained on this map. The county and its mapping companies assume no legal responsibility for the information on this map.

April 2, 2018

PIN: 9789247373
OWNER 1: UNIVERSITY OF N C
OWNER 2:
ADDRESS 1: PROPERTY OFFICE
ADDRESS 2:
CITY: CHAPEL HILL
STATE, ZIP: NC 27514
LEGAL DESC: S/W INT HWY 86 & ESTES DR

SIZE: 59.233 A
DEED REF: 000/000
RATECODE: 22
DATE SOLD: 10/22/2002
BLDG SQFT:
YEAR BUILT:

BUILDING COUNT:
LAND VALUE: \$355,400
BLDG_VALUE: \$0
USE VALUE: \$0
TOTAL VALUE: \$355,400

1:12,000

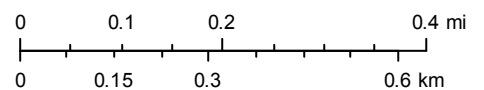

SITE PLAN

A MUNICIPAL SERVICES BUILDING
72,000 SQ. FT. X 3.5 FLOORS

B TOWN FUTURE BUILDING
28,000 SQ. FT. X 3.5 FLOORS

C UNIVERSITY FUTURE BUILDING
100,000 SQ. FT. X 3 FLOORS

SP SURFACE PARKING

TP TABLE TOP STRUCTURED PARKING

SCM STORM WATER CONTROL MEASURE

— STREAM CENTERLINE

- - - 50 FT. STREAM BUFFER



SITE SECTION A

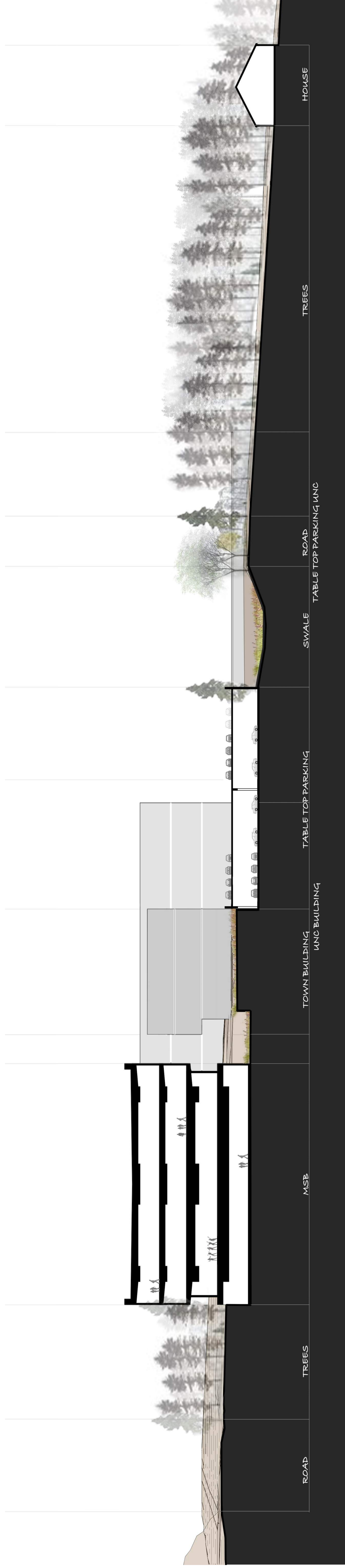

SITE SECTION B

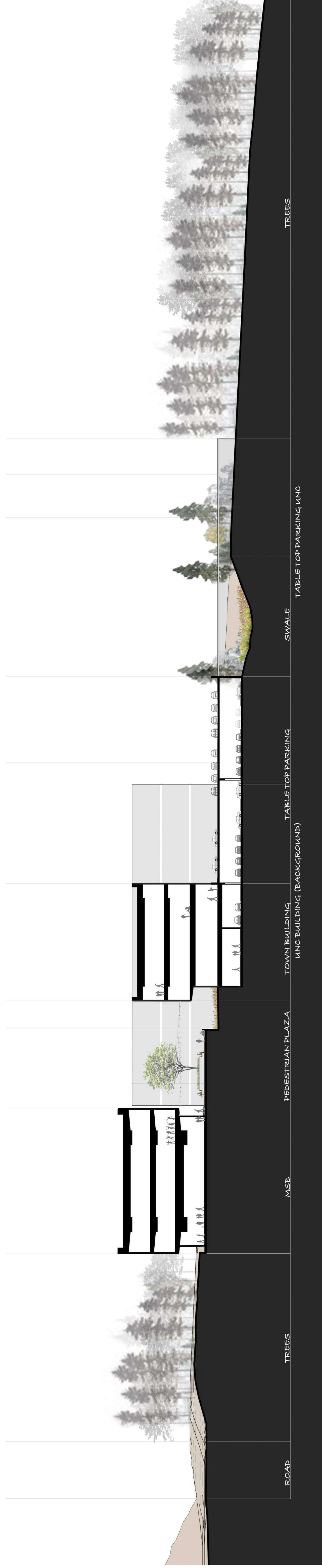



Exhibit L - Site Development Permit Application



**TOWN OF CHAPEL HILL
Planning Department**

405 Martin Luther King Jr. Blvd.
Chapel Hill, NC 27514-5705

phone (919) 969-5066 fax (919) 969-2014
www.townofchapelhill.org

U-1 Site Development Permit Application – University Joint Operations DA

A Site Development Permit is required for the construction of specific buildings described in the Town and University Joint Operations Development Agreement. The Town must, within 15 working days of submission of a complete application, either approve, approve with conditions, or deny the permit. For additional information, please contact the Planning Department at (919) 969-5066 at planning@townofchapelhill.org.

Accepted Date:	Deadline:
----------------	-----------

Section A: Project Information

Project Name: _____

Application Number: _____ Submittal Date: _____

Parcel Identifier Number (PIN): _____

Project Location: _____

Project Description: _____

Section B: Contact Information

Applicant Information (to whom correspondence will be mailed)

Name: _____

Address: _____

City: _____ State: _____ Zip Code: _____

Phone Number: _____ Email: _____

The undersigned applicant hereby certifies that, to the best of their knowledge and belief, all information supplied with this application is true and accurate.

Applicant Signature: _____ Date: _____

University Authorization (print name): _____

University Signature: _____

U-1 Site Development Permit Application

Section C: Floor Area

Pre-Application Floor Area:	
Additional Floor Area proposed with this project:	
Floor Area to be demolished with this project:	
NEW TOTAL FLOOR AREA:	

Section D: Vehicle Parking Spaces

Pre-Application Parking Spaces:	
Number of Parking Spaces to be added with this project:	
Number of Parking Spaces to be lost with this project:	
NEW TOTAL PARKING SPACES:	

Section E: Impervious Surface

Pre-Application Impervious Surface Area:	
Additional Impervious Surface Area proposed with this project:	
Impervious Surface to be removed with this project:	
NEW TOTAL IMPERVIOUS SURFACE:	

Section F: Impervious Surface

Pre-Application Impervious Surface Area:	
Additional Impervious Surface Area proposed with this project:	
Impervious Surface to be removed with this project:	
NEW TOTAL IMPERVIOUS SURFACE:	

U-1 Site Development Permit Submittal Requirements

The following must accompany your application. For questions concerning applicability of the requirements, please contact the Chapel Hill Planning Department at (919) 969-5066 or at planning@townofchapelhill.org. Please indicate in the space provided the location of the submittal requirements (i.e. Sheet #, Attached).

- | | |
|--|--|
| | 1. Application fee (refer to fee schedule) |
| | 2. Digital Files –provide digital files of all plans and documents |
| | 3. Minor Modification Approval letter , if applicable |
| | 4. Half-sized Site Plan Set (one copy) |
| | 5. Plan Sets (full-sized) 8 copies folded |
| | 6. Documentation of pre-submittal community meeting and 1000' notification. |
| | 7. Was a pre-application meeting held? Yes <input type="checkbox"/> No <input type="checkbox"/> |

Plans should be legible and clearly drawn. All sheets should be signed and sealed by a Licensed Professional in the State of North Carolina. All plan set sheets should include the following:

- Legend
- Labels
- North Arrow
- Property Boundaries
- Scale (Engineering), denoted graphically and numerically

Information for each of these categories should be included with application, when applicable.
(Sheet)

- | | |
|--|---|
| | 7. Area Map <ul style="list-style-type: none">a) Identify locationb) Dedicated open space, parks, greenways,c) Resource Conservation District, if applicabled) Property lines, zoning district boundaries, land uses, project names of site and surrounding properties, significant buildings, corporate limit linese) Existing roads (public & private), rights-of-way, sidewalks, driveways, vehicular parking areas, bicycle parking, handicapped parking, street names |
| | 8. Existing Conditions <ul style="list-style-type: none">a) Slopes, soils, environmental constraints, existing vegetation, and any existing land featuresb) Location of all existing buildings and usesc) Existing utilities & easements (location & sizes of water, sewer, electrical, & drainage lines)d) Nearest fire hydrantse) Nearest bus shelters and transit facilitiesf) Existing topography at minimum 2-foot intervals and finished grade of structureg) Natural drainage features & water bodies, floodways, floodplain, RCD, & Watershed boundaries |

9. Detailed Site Information

- a) Proposed building locations and footprints
- b) Access drives
- c) Pedestrian circulation (including connections to existing pedestrian networks)
- d) Location of proposed fire hydrants
- e) Location and dimension of all vehicle parking areas, entrances, exits, and drives
- f) Clearing limits

10. Grading Plan**11. Erosion and Sediment Control**

- a) Erosion and sediment control plan (2 copies) for projects over 20,000 square feet of disturbance (COURTESY COPY)
- b) Copy of NC Division of Land Resources erosion and sediment control permit application for projects disturbing one acre or more (COURTESY COPY)

12. Utility Plan

- a) Show the location of utilities and any reserved access areas.
- b) Letters of approval from each applicable utility

13. Transportation

- a) Traffic Impact Study completed by Town's consultant (or exception).
- b) Transportation Management Plan (TMP)

14. Construction Management Plan

- a) To be consistent with the University's "Construction Management Guidelines" contained in the August 7, 2001 Addendum, to be approved by the Town Manager prior to commencement of construction, indicating measures to be taken during construction
- b) If any part of a University project lies within a public right-of-way on Town streets, all documents required for an Engineering Construction Permit (ECP) must be submitted as part of the Site Development Permit application process. An ECP must be obtained from the Town prior to start of work on the right-of-way.

15. Traffic Management Plan

- a) A traffic management/control plan shall be submitted which will provide for the safe and orderly movement of motorized vehicles, non-motorized vehicles, or pedestrians on any public streets (maintained and operated by the Town or the NCDOT) on which normal traffic flow will be disrupted (lane closures, street closures, sidewalk closures, etc.) during construction, including a detour plan as may be necessary.
- b) A construction traffic routing map that identifies the local street network that will be impacted by construction traffic associated with the proposed addition. The routing plan shall minimize, and where practical, prohibit construction traffic on local streets. The plan shall also provide for the safe and continued use of bicycle, pedestrian, and greenway corridors during construction.
- c) The traffic control plan, for public streets, shall be prepared in accordance with the latest version of Manual on Uniform Traffic Control Devices (MUTCD) and applicable NCDOT

- d) All signs shall be made of high retro-reflectivity material and, if night time closures are necessary, signs shall include beacons.
- e) A permit must be obtained from the Town Manager for lane closures, sidewalk closures, and street closures in the public right-of-way. The plan shall state that closures and night time work on public streets must be approved by the Town Manager. This form must be completed and submitted to the Town for approval along with the relevant traffic control plan. The Contractor must notify the Public Works, Police, Fire, and Transportation Departments, E911, and affected residents at least 3 business days prior to the commencement of approved night work and/or approved street closure.



16. Pedestrian Management Plan

- a) A pedestrian detour plan shall be submitted which will provide for the safe and orderly movement of pedestrians if any public sidewalks and/or designated pedestrian routes on public sidewalks and/or designated pedestrian routes on public rights-of-way and/or easements are disrupted or closed to normal pedestrian use.
- b) The pedestrian detour plan involving public right-of-way shall be prepared in accordance with the latest of the MUTCD and sealed by a professional engineer licensed in the State of North Carolina.
- c) All signs shall be made of high retro-reflectivity material and if a night time detour is required, signs shall include beacons.
- d) Detailed information on how the plan will provide for the safe and continued use of bicycle, pedestrian, and greenway corridors during construction.
- e) Detailed information on pedestrian security measures including the placement of security phones and lighting. The plan shall also include additional information on security for pedestrian bridges during evening hours.



17. Construction Traffic Management Plan

- a) The plan shall be submitted which will provide for the safe and orderly movement of construction traffic to and from the construction site and staging area. The plan must identify the location and size of staging areas and material storage areas which would affect construction traffic routes.
- b) The plan shall indicate location(s) where construction equipment will be parked (if offsite) and where construction personnel will park, including a routing plan for equipment and personnel going to and from the work site.
- c) The plan shall indicate graphically and describe how emergency vehicle access to and around the project site will be provided both during and after completion of construction
- d) The plan shall include measures to minimize construction traffic impacts on school bus traffic and access to schools in the vicinity of the project.
- e) Each construction site will include visible signage listing a telephone number and a University representative available to answer questions and respond to concerns about pedestrian safety and security. A detail of the proposed sign, including number of signs and general locations, shall be submitted with each Site Development Permit application.



18. Stormwater Management

- a) A signed and sealed letter from a Professional Engineer, licensed in the State of North Carolina, certifying that the stormwater management measures associated with the Site Development Permit application meet or exceed the approved stormwater management performance standards for Carolina North. Stormwater management and treatment practices shall comply with all applicable federal and State regulations, and revisions thereof.

- b) Plans, signed and sealed by a Professional Engineer, licensed in the State of North Carolina, showing grading, regulatory floodplains, stream buffers and RCDs, plantings, erosion control, and stormwater runoff control best management practice(s) designs and details, in accordance with the performance criteria.
- c) A stormwater design report, signed and sealed by a Professional Engineer, licensed in the State of North Carolina, that includes the following:
 - (i) A narrative description of existing and proposed stormwater management measures
 - (ii) A summary table of pre-development and post-development impervious cover by drainage area
 - (iii) Plan showing the pre-development and post-development impervious cover
 - (iv) A table indicating the stormwater runoff volumes and peak discharge (rates) for the specified storms at the following three conditions: pre-development; post-development without stormwater management; and post-development with stormwater management.
 - (v) Copies of all hydrologic and hydraulic calculations and routings
 - (vi) Maps indicating the existing and proposed drainage divides on the site and the drainage to each stormwater management measure
 - (vii) Inspection, operations, and maintenance plans for the proposed stormwater management structures (for information only)
- d) A note indicating the University is responsible for maintenance of stormwater facilities as agreed upon in the Carolina North Development Agreement for facilities on University-owned property.



19. Noise

- a) Every application for a Site Development Permit shall include a signed and sealed letter from a Professional Engineer, licensed in the State of North Carolina, and with demonstrable expertise in acoustical design and attenuation practices, certifying that any increase in measurable noises above existing pre-Development Plan noise levels on property outside the U-1 Zoning District will not exceed the levels allowed in the Town Noise Ordinance as established at the time each Site Development Permit application is approved by the Town. This noise restriction shall not apply to property outside of the U-1 Zoning District that is in the same ownership as property within the U-1 Zoning District.



20. Lighting

- a) Existing and proposed lighting fixture types and locations
- b) Isolux contour diagram and grid points with the measured and calculated pre-development and post-development foot-candles at grade on property where lighting impacts are expected.
- c) A description of how lighting meets the goals of 'dark skies' lighting and complies with the lighting standards of the Development Agreement.
- d) A demonstration that there is no increase in lighting foot-candle levels at the adjacent property line as a result of this project.
- e) Demonstration that increases in illumination on property outside of the Carolina North Project do not result in lighting levels in excess of 0.3 foot candles, measured at ground level.
- f) Confirmation that, for property outside of the Carolian North Project where existing ambient lighting levels are in excess of 0.3 foot-candles, there is no increase in measurable lighting levels.



21. Fire Protection and Safety

- a) Fire Flow Report sealed by a registered Professional Engineer, licensed in the State of North Carolina, demonstrating compliance with Town Standards.
- b) Locations of existing and proposed fire hydrants and Fire Department Connections (FDC). Hydrant spacing shall comply with the Town Design Manual and FDC locations shall be within 100 feet of hydrant.
- c) Any and all roads, driveways, or dedicated fire lanes used for fire department access shall be all-weather and designed to support fire apparatus weighing at least 80,000 lbs.
- d) Fire access roads shall have a minimum width of 20 feet with overhead clearance of 13 feet 6 inches for all structures not exceeding 30 feet in height and shall provide access to within 150 feet of all exterior portions of the building. Structures of 3 stories or exceeding 30 feet in height shall have an access road of at least 26 feet in width. Proximity to the building for aerial apparatus shall have at least one of the required access routes be located within 15 feet and a maximum of 30 feet from the building and shall be positioned parallel to one entire side of the building.
- e) All turns, radii, bridges, and depressions within the roadway shall be designed and constructed to be accessible by the largest fire apparatus operated by the Town of Chapel Hill.
- f) Provide details on signage, bollards, and/or markings used to prevent parking that would hinder access.
- g) If a Certificate of Occupancy is issued by the Town of Chapel Hill, fire protection devices, where required by the NC Fire Prevention Code, Town of chapel Hill Code (Chapter 7), and applicable NFPA codes will be required to be permitted, installed, tested, and approved.
- h) Fire apparatus access roads shall be installed and made serviceable prior to and during the time of construction, except when approved alternate means of protection are provided and approved by the AHJ.
- i) During construction, vehicle access for firefighting shall be provided. Temporary street signs shall be installed at each street intersection when construction allows the passage of vehicles. Signs shall be of an approved size, weather resistant, and maintained until replaced by permanent signs.
- j) Please include the following note on the submitted plans: During demolition and/or construction, all aspects of the NC Fire Prevention code shall be followed. The owner/developer shall designate one person to be the Fire Prevention Program Superintendent who shall be responsible for enforcing Chapter 14 of the NC Fire Prevention Code (Chapter 14) and the on-site fire prevention program and ensure that is carried out through completion of the project.
- k) When the building being constructed requires standpipes, a temporary standpipe connection will be constructed with ready Fire Department Access when the building is not more than 40' in height. Such standpipes shall provide usable connections adjacent to the stairs and shall continue with building progression always being not more than one floor below the highest floor of the building. NC FPC 2012 Section 1413.
- l) Fencing around project to include access gates with a 20 foot swing or slide motion. Any areas which will be inaccessible for firefighting or rescue operations shall be noted. Emergency access designation for apparatus shall be provided.
- m) An approved water supply for fire protection, either temporary or permanent, shall be made available as soon as combustible material arrives on the site. NC FPC 1412.



n) Energy and Conservation Goals

- a) Permit applications shall include energy performance models and the LEED checklist with project points to qualify at Silver level.
- b) Permit applications shall describe how potable water consumption and reclaimed strategies are incorporated into the project.
- c) Energy Management Plan including the following:
 - I. Description of how project will be 20% more energy efficient than ASHRAE standards
 - II. Description of utilization of sustainable forms of energy (Solar, Wind, Hydroelectric, and Biofuels)
 - III. Participation in NC GreenPower program
 - IV. Description of how project will ensure indoor air quality, adequate access to natural lighting, and allow for proposed utilization of sustainable energy
 - V. Description of how project will maintain commitment to energy efficiency and reduced carbon footprint over time
 - VI. Description of how the project's Transportation Management Plan will support efforts to reduce energy consumption as it affects the community



o) Landscape

- a) Plans indicating grading and limits of construction, existing and proposed tree canopy mix and percent coverage, and other proposed plantings.
- b) Identify planting materials, proposed irrigation and maintenance techniques for each type of landscape proposed.
- c) Applications should include any proposed trails, greenways or recreation facilities, and connections to adjacent related facilities to be constructed as part of the project and describe the design standards applied to those elements.



p) Exterior Elevations

- a) An outline of each elevation of the building, including the finished grade line along the foundation (height of building measured from mean natural grade)

Elkin Hills Project Area

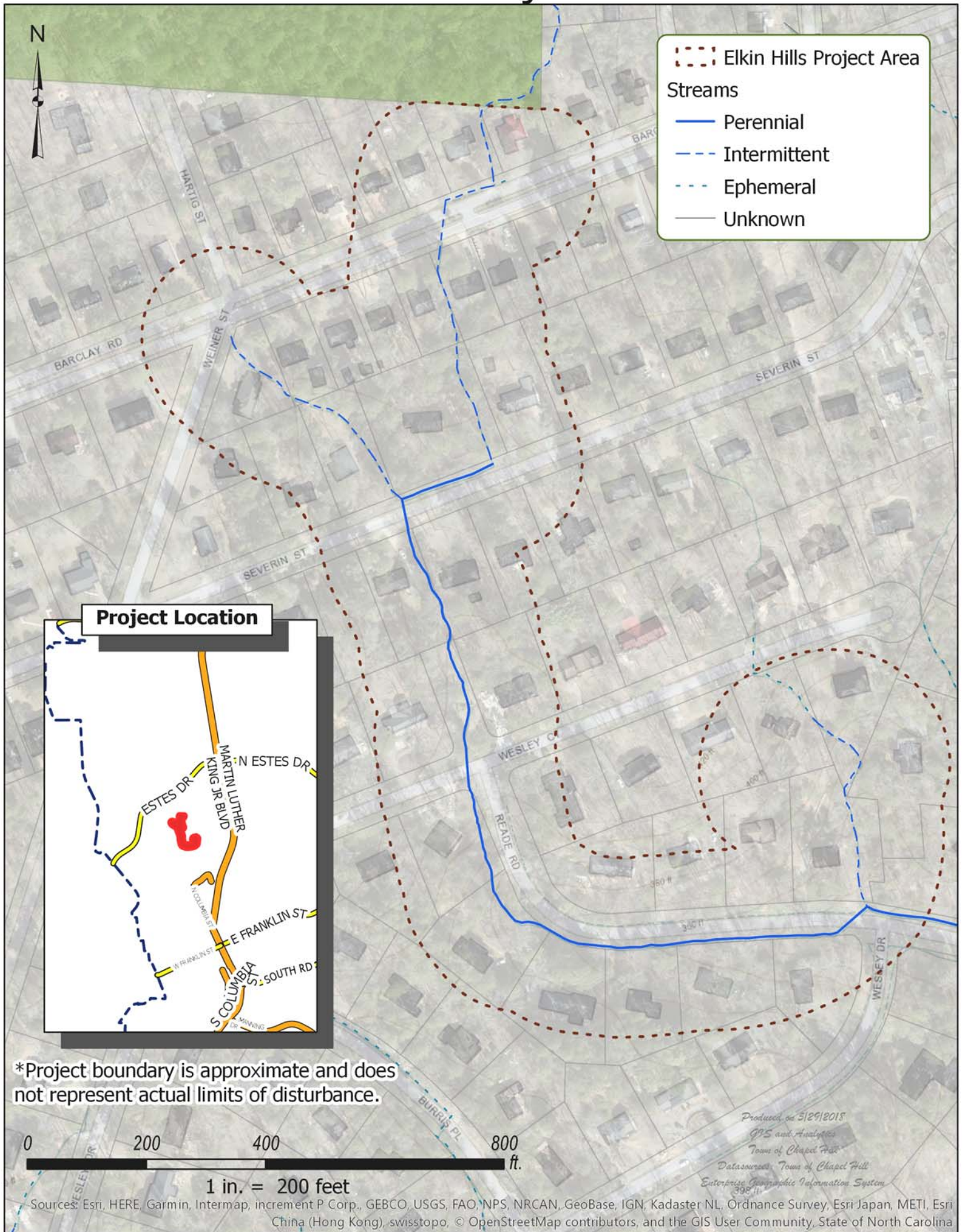

*Project boundary is approximate and does not represent actual limits of disturbance.

Exhibit N - Advisory Board Recommendations

PLANNING COMMISSION

The charge of the Planning Commission is to assist the Council in achieving the Town's Comprehensive Plan for orderly growth and development by analyzing, evaluating, and recommending responsible town policies, ordinances, and planning standards that manage land use and involving the community in long-range planning.

REVIEW AND COMMENT OF PLANNING COMMISSION TO THE TOWN COUNCIL

April 17, 2018

Municipal Services Center Development Agreement

The Planning Commission reviewed the Municipal Services Center draft development agreement and provided the following comments and questions regarding the development agreement:

- The Commission was interested in what type of permitting process the future University building would be subject to.
- The proposed land uses are concerning in that evening activities could be permitted that would affect adjacent properties. The Commission was interested in restricting the types of land uses and/or hours of activities.
- The Commission would like to see the future community engagement structure refined in the Development Agreement.
- The Commission supports the proposed buffer.
- The Commission supports the recommendations of the Transportation and Connectivity Advisory Board.
- The Commission supports the connectivity proposals.
- Change the phrasing regarding proposed albedo from “low” to “high”
- The University should be present during public discussion of this project.
- The Commission supported the use of permeable pavers.
- The Commission would like to see the parking deck evaluated for potential future repurposing.
- The Commission wanted to clarify that street parking should not be provided on Estes, although is comfortable with street parking on the internal drive aisles.
- The Commission asked that angled parking be proposed to reduce parking surface.

Prepared by: Aaron Frank, Planning and Development Services Staff

ENVIRONMENTAL STEWARDSHIP ADVISORY BOARD

The charge of the environmental stewardship advisory board will be to assist the Chapel Hill Town Council in strengthening environmentally responsible practices that protect, promote and nurture our community and the natural world through advice and program support.

REVIEW AND COMMENT OF ENVIRONMENTAL STEWARDSHIP ADVISORY TO THE TOWN COUNCIL

April 10, 2018

Municipal Services Center Development Agreement & Rezoning

The Environmental Stewardship Advisory Board reviewed the Municipal Services Center draft development agreement and rezoning and provided the following comments and questions regarding the development agreement:

- The development should strive to meet AIA 2030 goals, and the Land Use Management Ordinance may be amended to require this.
- The development should strive for nearly net zero runoff, while providing stormwater runoff to the wetland areas on the site.
- Three to four building stories provides optimal opportunities to construct an environmentally efficient building.
- The access road should be designed to the north or south of existing location to reduce encroachment within the Resource Conservation District.
- The Board asked if specific access or driveway requirements exist for police vehicles.
- The Board asked if an agreement could be reached to reduce audible presence of police sirens.
- The Board asked for quantifiable outcomes in stormwater management, and that stormwater runoff achieve a measureable reduction from existing conditions.
- The Board asked that the applicant agree to native plantings. Additional preference for drought tolerance was stated following the meeting
- The Board asked that the applicant ensure that no light trespass be permitted.
- The Board asked that a box culvert be provided.
- The Board asked that the stream determinations be provided to them.

Prepared by: John Richardson, Community Resilience Officer, Staff Liaison to ESAB

TRANSPORTATION AND CONNECTIVITY ADVISORY BOARD

To assist the Chapel Hill Town Council in creating an inclusive connected community by recommending, advocating and planning for comprehensive, safe, effective and sustainable multi-modal transportation and connectivity

Municipal Services Building Development Agreement Comments on the proposed standards and concept plan March 27, 2018

- The Board wants to see this site maximize access to transit. The Hartig St. path connection will help people access the A route bus stop on Barclay. The connection will provide a direct bike route downhill to downtown Chapel Hill using the greenway systems and local roads without getting on Estes Dr.
- They're interested in making sure the site has good connectivity from Hartig path connection through the parking lot to the other buildings. This means providing safe places to walk and bike—installing sidewalks and crosswalks.
- The Hartig St. path connection needs to be ADA compliant, 10 feet, and paved.
- Board members like the idea that the cross section on Estes Drive Extension will match the design that will be constructed on Estes Drive (MLK –Caswell). They would like to see the traffic signal at MLK and Estes to give preemption to bicyclists and pedestrians.
- If traffic signals are not warranted on Estes Drive Extension, the Board recommends crosswalks using Rectangular Rapid Flashing Beacons or other safe pedestrian crossing treatments.
- The Board would like staff to take a look at bus pull off on Estes Drive Extension. There is a concern that if buses stop in the travel lane that cars will try to pass the bus using the center turn lane.
- The Board is interested in seeing good lighting along the sidewalk. Cars speed on Estes Drive and with the curvy road it currently hard to see people walking or biking in the dark.
- The Board would like to see electric vehicle charging spaces provided and conduit for future expansion.
- The Board would like staff to evaluate how the parking deck can be constructed to be reused for other purposes in the future as transportation technology changes.
- The Board recommends that the travel lanes on Estes Drive Extension do not exceed 11 ft wide.
- The Board would like to make sure Police and Fire weigh in on the site and circulation to make sure it meets the needs for emergency vehicles.

COMMUNITY DESIGN COMMISSION REVIEW COMMENTS
MUNICIPAL SERVICES CENTER
March 27, 2018

The Commission offered the following comments to the applicant:

- In response to a citizen comment, the Commission was interested in the real estate assessment that would show the impact of the development on neighborhood property values.
- The buildings appear buffered from Estes Drive. Why not move the building toward the street? The applicant replied that it was proposed to be close to the street to allow additional buffer from the Elkin Hills neighborhood. The illustrative site plan made it appear the building was separated from the street by vegetation.
- Wanted information on bus stops and wanted to see stops with shelters.
- The CDC should review/approve the Building Elevations our own Town projects, not just a Courtesy Review.
- The new police building should include daylighting to make it bright inside.
- It appeared that community members chose images that were urban in appearance.
- Arrange the buildings to create site lines (terminated vistas) and defined common areas
- Look at adding trees between the sidewalk and street
- Look at adding on-street parking

Prepared By: Dixon Pitt, Chair, Community Design Commission
Kay Pearlstein, Staff

MEMORANDUM

TO: Mayor and Town Council

FROM: Stefan Klakovich, Chair, Stormwater Management Utility Advisory Board

SUBJECT: Municipal Services Center (Estes Dr. Ext.) Development Agreement – Stormwater Advisory Board recommendations

DATE: April 25, 2018

The Stormwater Management Utility Advisory Board (Board) appreciates this opportunity to provide recommendations to the Mayor and Town Council members for their consideration during the Council's deliberations on the development agreement for the proposed Municipal Services Center on Estes Drive Extension.

Following a presentation at its April 24, 2018 meeting by Mary Jane Nirdlinger and Dennis Pitts, the Board discussed and approved an initial set of recommendations listed below.

1. Peak Discharge Rate Limits to include the 50-year storm

The Stormwater Advisory Board recommends that the 50-year 24-hour storm event be included to the peak discharge rate limits requirements. This is in addition to the 1-year, 2-year, and 25-year 24-hour storm events. This is consistent with the peak discharge rate requirements contained in the Carolina North Development Agreement

Further, the Board recommends that increase in impervious surfaces associated with the Estes Dr. Ext. road improvements be included in the peak discharge rate calculations.

2. Flood Storage Study

In response to the concerns of increased flooding from the Elkin Hills residents, the Board recommends that a study be conducted for this catchment area in order to identify potential flood storage sites that could provide a greater community benefit.

The Board appreciates the improvements already made to the plans in response to input from residents and advisory boards. This includes the change to the “loop road” by realigning the stream crossing (closer to perpendicular), which shortened its length and reduced its width.

The Board encourages the Town Council to consider other strategies to lessen the stormwater impacts to adjacent properties and reduce the amount of impervious surfaces such as green roofs and deleting the median along the east driveway.

Motion made by Mr. Bevington; Mr. Hearn seconded the motion. It passed unanimously.

**TOWN OF CHAPEL HILL
MUNICIPAL SERVICES CAMPUS**

TRAFFIC IMPACT STUDY



Prepared for:

The Town of Chapel Hill
Public Works Department - Engineering

Prepared by:

HNTB North Carolina, PC

*343 East Six Forks Road
Suite 200
Raleigh, NC 27609*

NCBELS License #: C-1554

February 2018

HNTB

**TOWN OF CHAPEL HILL
MUNICIPAL SERVICES CAMPUS**

TRAFFIC IMPACT STUDY



Prepared for:

The Town of Chapel Hill
Public Works Department - Engineering

Prepared by:

HNTB North Carolina, PC

*343 East Six Forks Road
Suite 200
Raleigh, NC 27609*

NCBELS License #: C-1554

February 2018

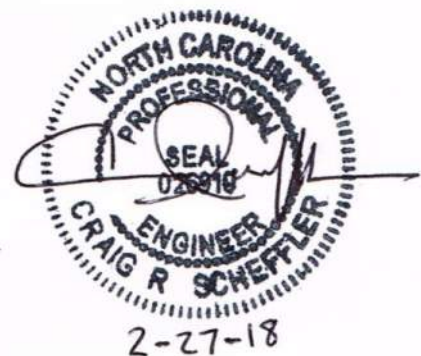



Table of Contents

	<u>Page</u>
LIST OF FIGURES	ii
LIST OF TABLES/APPENDICES	ii
I. Existing Conditions.....	1
A. Project Overview	1
B. Site Location and Study Area	1
C. Site Description.....	1
D. Existing and Proposed Uses in Vicinity of Site	2
E. Existing and Committed Surface Transportation Network	2
F. Existing Traffic Conditions	5
II. Future Build-Out Year Conditions	6
A. Future Ambient Area-Wide Traffic Growth Estimation	6
B. Approved Background Development Traffic Estimation.....	6
C. Proposed Project Traffic	7
i.) Trip Generation.....	7
ii.) Adjustments to Trip Generation Rates	8
iii.) Trip Distribution	8
iv.) Trip Assignment	9
D. Future Traffic Forecasts with the Proposed Development.....	9
III. Impact Analyses	9
A. Peak Hour Intersection Level-of-Service Analysis.....	9
i.) Methodology	9
ii.) 2017 Existing Conditions Results	11
iii.) 2021 No-Build Scenario (Condition 2) Results.....	11
iv.) 2021 Build Scenario (Condition 3) Results	13
v.) 2021 Build + Mitigation Scenario (Condition 4) Results.....	15
B. Access Analysis.....	15
C. Signal Warrant Analysis	16
D. Sight Distance Analysis	16
E. Crash Analysis.....	16
F. Other Transportation-Related Analyses	17
G. Special Analysis/Issues Related to the Project.....	17
IV. Mitigation Measures/Recommendations	18
A. Planned Improvements.....	18
B. Background Committed Improvements.....	19
C. Applicant Committed Improvements	19
D. Necessary Improvements.....	19



List of Figures

Figure

- 1) Project Study Area
- 2) Preliminary Site Plan
- 3) Existing Laneage & Geometrics
- 4) Study Area Pedestrian & Bicycle Facilities
- 5) Study Area Transit Routes
- 6) Town of Chapel Hill – Estes Drive Improvements Schematic Detail
- 7) 2017 Existing Peak Hour Traffic Volumes
- 8) 2021 Ambient Growth Peak Hour Traffic Volumes
- 9) Background Development Locations
- 10) 2021 Total Background Generator Peak Hour Traffic Volumes
- 11) 2021 Peak Hour Traffic Without Site – Phase 1
- 12) 2021 Site Trip Distribution Percentages – Phase 1
- 13) 2021 Peak Hour Site Traffic Assignment – Phase 1
- 14) 2021 Peak Hour Traffic With Site – Phase 1
- 15) 2021 Committed Improvements
- 16) Necessary Improvements

List of Tables

Table	<u>Page</u>
1) Existing Study Area Roadways	2
2) Existing Study Area Intersection Details	3
3) Current Study Area Weekday Transit Service	4-5
4) Traffic Count Information	6
5) Study Area Background Development Status.....	7
6) Phase 1 Weekday Peak Hour Vehicle Trip Generation Summary	8
7) Level of Service (LOS) Characteristics	10
8) Capacity Analysis Results - Condition 1 – 2017 Existing Traffic	12
9) Capacity Analysis Results - Condition 2 – 2021 Traffic Without Site.....	13
10) Capacity Analysis Results - Condition 3 – 2021 Traffic With Site (Phase 1)	14
11) Capacity Analysis Results - Condition 4 – 2021 Traffic With Site & Mitigation	15
12) Study Area Crash Rate Comparison – Estes Drive Extension Corridor	17
13) Other Transportation-Related Analyses.....	18

Appendices

- A. Figures
- B. Traffic Count Data
- C. Background Traffic Generator Data
- D. Scenario Volume Development Spreadsheet Output
- E. Synchro Signalized Analysis Output
- F. Synchro Unsignalized 2010 HCM Analysis Output
- G. Peak Hour Signal Warrant Analysis
- H. Crash Data



I. EXISTING CONDITIONS

A. Project Overview

A new municipal services campus for the Town of Chapel Hill is being proposed along the Estes Drive Extension near its intersection with Seawell School Road. The project proposes to create multiple buildings for Town services and potential uses for future office space for the University of North Carolina – Chapel Hill (UNC). **Figure 1** (found in **Appendix A**) shows the general location of the site. Phase 1 of the project is anticipated to be fully complete by 2020. This report analyzes the Phase 1 build-out scenario for the year 2021 (one year after anticipated completion of Phase 1), the no-build scenario for 2021, as well as 2017 existing year traffic conditions. Future phased development of the site will require updates to this Phase 1 traffic impact study when that development occurs.

The proposed site concept plan shows a provision for two full movement access driveways that connect to the Estes Drive Extension. No other vehicular access connections are proposed. The site driveways are proposed to have internal connectivity with on-site parking areas. **Figure 2** displays the preliminary concept plan of the Town of Chapel Hill Municipal Services Campus and nearby land uses and roadways. The site is expected to provide approximately 168 parking spaces on surface lots in its first phase.

B. Site Location and Study Area

This report analyzes and presents the transportation impacts that the Town of Chapel Hill Municipal Services Campus will have on the following intersections in the project study area:

- Estes Drive Extension and Seawell School Road
- Estes Drive Extension and UNC Student RR Lot / Future West Site Driveway
- Estes Drive Extension and Potential Future Carolina North Access / Future East Site Driveway
- Estes Drive Extension and Airport Drive
- Estes Drive Extension / Estes Drive and NC 86 (Martin Luther King, Jr. Boulevard)
- NC 86 (Martin Luther King, Jr. Boulevard) and Airport Drive

The impacts of the proposed site at the study area intersections will be evaluated during the AM, noon, and PM peak hours of an average weekday. The following study is based on background traffic for the existing year, 2017, the year following the estimated Phase 1 site build-out (2020), as well as the estimated Phase 1 site-generated traffic produced by the Town Services Campus.

There are several Town-approved or anticipated future developments in, or just beyond, the immediate project study area that were considered to be constructed by 2021 and may generate additional background traffic. An area-wide ambient future traffic growth percentage of 1.0 percent per year was applied to the existing volumes, based on historical average annual daily traffic (AADT) growth rate data provided by the Town of Chapel Hill and NCDOT, and consistent with recent traffic impact studies near the project study area.

C. Site Description

The Town Municipal Campus site is currently owned by UNC and contains a large amount of undeveloped, wooded land. It borders Carolina North property to the north and single-family residential developments to the west and south. It also borders UNC property to the east. Additional residential subdivisions, commercial and institutional developments are present along the NC 86 (Martin Luther King, Jr. Boulevard) corridor in the project study area.



The site has frontage along the Estes Drive Extension which will provide all vehicular access. The proposed site concept, shown in **Figure 2**, indicates all parking for Phase 1 will be accommodated on-site, through the use of surface parking facilities. The two proposed site driveways will include internal connections to parking areas adjacent to the proposed campus buildings. The proposed driveways are located to form future four-legged intersections with the existing UNC Park-and-Ride facility and a future connection to Carolina North development.



D. Existing and Proposed Uses in Vicinity of Site

The land uses and development in the study area are primarily residential and institutional, with some commercial areas located along Martin Luther King, Jr. Boulevard. The Existing Land Use Plan shown in the 2021 *Town of Chapel Hill Comprehensive Plan* and adopted June 25, 2012, indicates that the proposed site is designated as “Institutional”. The Future Land Use Plan, that is also a part of the Town Comprehensive Plan, indicates that the parcel would be considered as “University”. The Comprehensive Plan also indicates that this parcel is a “Future Focus Discussion Area – S. MLK Jr. Boulevard / Homestead Road to Estes Drive”. The parcel is currently zoned “OI-2” – delineating it as “office and institutional use”.

E. Existing and Committed Surface Transportation Network

Roadways

The Town of Chapel Hill Municipal Services Campus project study area features several major and minor arterial roadways serving areas throughout the Town of Chapel Hill and points beyond, as well as a number of collector and local access streets. **Table 1** summarizes pertinent information on the study area roadway facilities.

Table 1. Existing Study Area Roadways

Road Name	Functional Classification*	Study Area Cross-Section	2015 AADT	Speed Limit	Sidewalk	On-Street Parking
N.C. 86 (Martin Luther King, Jr. Blvd)	Other Principal Arterial	5 lane undivided with TWLTL	29,000	35	Y	N
Estes Drive	Minor Arterial	2 lane undivided	16,000	35	Y	N
Estes Drive Extension	Minor Arterial	2 lane undivided	13,000	35	N	N
Seawell School Road	Minor Collector	2 lane undivided / 3 lane undivided with TWLTL	4,100	35	Y	N
Airport Drive	Local	2 lane undivided	N/A	25	S	N

S – Some Sidewalk/Parking Present TWLTL – Two-Way Left-turn Lane

* - As defined on the NCDOT Functional Classification web page <http://ncdot.maps.arcgis.com/home/webmap/viewer.html>



AADT data was taken from 2015 AADT mapping produced by the NCDOT Traffic Survey Unit. Figure 3 shows the existing lane configuration, traffic control, and speed limits for these study area roadways. Detailed descriptions of several of the major study area roadways are as follows:

- **N.C. Highway 86 (Martin Luther King Jr, Blvd)** is a principal arterial in the study area, serving areas from I-40 (via Martin Luther King Jr. Boulevard) to downtown Chapel Hill and the US 15-501 corridor to the south. In the study area vicinity, Martin Luther King, Jr. Boulevard is a five-lane undivided section (with two-way left-turn lane). There are multiple driveway access points along the roadway and several major street intersections. No on-street parking is permitted along N.C. 86 in the project study area. Several bus stops are located along the facility. The posted speed limit is 35 mph in the study area.
- **Estes Drive / Estes Drive Extension** is a minor arterial that connects areas of west and north Chapel Hill. In the study area, Estes Drive and Estes Drive Extension are undivided facilities with two-lane cross-sections near NC 86 and both have a 35 mph speed limit. Auxiliary turn-lanes are present at major intersections. Sidewalk is present on at least one side of the roadway along Estes Drive, but no sidewalk is present along Estes Drive Extension. Several bus stops are located along the facilities.
- **Seawell School Road** is a collector roadway that provides access to residential neighborhoods and multiple schools along the facility. It is primarily a two-lane facility, with some sections having a continuous center left-turn lane. Some sections of sidewalk are also present. The posted speed limit is 35 mph on Seawell School Road.
- **Airport Drive** is a two-lane local access roadway for UNC properties and residential neighborhoods just south of the Estes Drive Extension and west of NC 86.

Intersections

Table 2, below, summarizes all five existing study area intersections, traffic control features, and pedestrian amenities at each. Laneage details and intersection turn bay lengths are also detailed on Figure 3.

Table 2. Existing Study Area Intersection Details

Intersection	Traffic Control	Signal Phases	Signal Operation	Cross walk	Ped Signals
Estes Drive Extension and Seawell School Road	Signal	3	Free-Run	No	No
Estes Drive Extension and UNC Student RR Lot	TWSC	N/A	N/A	No	No
Estes Drive Extension and Airport Drive	TWSC	N/A	N/A	No	No
Estes Drive Extension / Estes Drive and NC 86 (Martin Luther King, Jr. Boulevard)	Signal	8	Coordinated	Yes (1)	Yes (1)
NC 86 (Martin Luther King, Jr. Boulevard) and Airport Drive	TWSC	N/A	N/A	No	No

TWSC = Two-Way Stop Controlled Intersection

The project study area along the Estes Drive Extension features a mixture of signalized and unsignalized intersections. The N.C. 86 (Martin Luther King, Jr. Boulevard) corridor features coordinated signal operation for weekday peak hours.



Bicycle Routes and Sidewalks

Specific bicycle facilities are present in the immediate study area, with sharrow markings in both directions along Martin Luther King, Jr. Boulevard south of Estes Drive Extension. No other bicycle facilities are currently present. Pedestrian sidewalk is found along both sides of Martin Luther King Jr. Boulevard through the study area. Additional connectivity exists along the Estes Drive corridor from Martin Luther King, Jr. Boulevard eastward on the south side of the road. Sidewalk is also present on one side of Seawell School Road north of the Estes Drive Extension. A crosswalk and pedestrian signal is present across Estes Drive at the Martin Luther King, Jr. Boulevard intersection. **Figure 4** displays a schematic of existing pedestrian and bicycle facilities in the project study area.

Transit Routes

Current Chapel Hill Transit (CHT) Routes A, G, HS, NU, NS and T serve the project study area along NC 86 (Martin Luther King, Jr. Boulevard) and the Estes Drive Extension with weekday bus service (T Route also provides Saturday service). Several bus stops, with a range of amenities (shelters, benches), are present in the study area. **Table 3** details the six current CHT routes serving the study area. Most buses run on 10, 20, 30, or hour headways during weekday peak service periods. Only the HS and NU Routes currently provide service directly to the proposed site along the Estes Drive Extension.

GoTriangle provides regional bus service to the immediate study area via the 420 Route that runs along NC 86 between Chapel Hill and Hillsborough. Service for this route occurs at 30 minute headways during peak weekday periods. GoTriangle also provides express bus service from Chapel Hill to Raleigh on the CRX Route that operates along NC 86 (Martin Luther King, Jr. Boulevard) in the study area on 30 minute headways during weekday peak hours.

Table 3. Current Study Area Weekday Transit Service

Route	Headways (minutes)			Study Area Stops	Destinations
	AM Peak	PM Peak	Off Peak		
Chapel Hill Transit					
A	10-20	30	30	<ul style="list-style-type: none"> • NC 86 Corridor 	<ul style="list-style-type: none"> • Downtown Chapel Hill • UNC Campus/Hospitals Area
G	35	50	45-50	<ul style="list-style-type: none"> • NC 86 Corridor • Estes Drive 	<ul style="list-style-type: none"> • Downtown Chapel Hill • Glen Lennox/University Place
HS	30	30**	30	<ul style="list-style-type: none"> • Estes Drive Extension • Seawell School Road 	<ul style="list-style-type: none"> • Rogers Road Area • Homestead Road • NC 86 Corridor
NS	10	20	10	<ul style="list-style-type: none"> • NC 86 Corridor 	<ul style="list-style-type: none"> • UNC Campus/Hospitals Area • Eubanks Park and Ride • Southern Village Park and Ride
NU	20	20	20	<ul style="list-style-type: none"> • UNC RR Lot • Airport Drive 	<ul style="list-style-type: none"> • UNC Main Campus • UNC Hospitals
T	25-30	35	35	<ul style="list-style-type: none"> • NC 86 Corridor 	<ul style="list-style-type: none"> • Tymberline Shopping Center • Downtown Chapel Hill • E. Chapel Hill HS/Cedar Falls Pk

Source: CHT 2017 Fall Ride Guide



Table 3 (Continued). Current Study Area Weekday Transit Service

Route	Headways (minutes)			Study Area Stops	Destinations
	AM Peak	PM Peak	Off Peak		
GoTriangle					
420	30	30	N/A	<ul style="list-style-type: none"> • NC 86 Corridor 	<ul style="list-style-type: none"> • Hillsborough • Downtown Chapel Hill/UNC Campus
CRX	15-35	15-35	N/A	<ul style="list-style-type: none"> • None (Express Service) 	<ul style="list-style-type: none"> • Downtown Chapel Hill/UNC Campus • Eubanks Park-and-Ride • Raleigh

Source: <http://www.gotriangle.org/maps-and-schedules>

Figure 5 displays transit routes and bus stops that currently exist in the project study area. The potential for transit trips are accounted for in the Town of Chapel Hill Municipal Services Campus site in the following sections of this report, as the proximity and frequency of transit service directly near proposed site may account for a measurable portion of site trips.

Recommended/Committed Surface Transportation Improvement Projects

There is one committed/programmed NCDOT State Transportation Improvement Program (STIP) project – STIP EB-5886, which will construct a multi-use path, additional sidewalks and bicycle lanes along the Estes Drive Extension from N Greensboro Street to NC 86 (Martin Luther King, Jr. Blvd). Right-of-way acquisition is scheduled for 2020 and construction for 2021. This improvement was considered to be complete for the 2021 analysis year.

The Town of Chapel Hill, in cooperation with NCDOT, also has a transportation improvement project to construct sidewalk and bicycle lanes along Estes Drive east of NC 86 (Martin Luther King Jr. Blvd), which will also include laneage improvements to the Estes Drive/NC 86 intersection. This project was considered to be complete for the 2021 analysis year. Figure 6 shows a schematic representation of the improvements from the January 2016 Public Hearing Map.

There are no private development-related projects to improve roadway facilities in the study area that are expected to be complete by 2021. Several development projects near the study area have recommended, as part of their traffic impact study reports, reoptimization of traffic signals along the NC 86 (Martin Luther King, Jr. Blvd) corridor. This was considered to be included as part of the Town project improvements at this intersection.

There are numerous additional recommended improvements to transportation facilities in Town of Chapel Hill Municipal Services Campus project study area that may occur as the Carolina North development progresses just to the north of the project study area. However, any additional improvements due to Carolina North were considered post-2021 Phase 1 analysis year for the purposes of this study.

F. Existing Traffic Conditions

Figure 7 shows the existing AM, noon, and PM peak hour traffic volumes for the study area intersections. The counts used to determine these volumes were conducted in February 2018 for all study area intersections during the weekday periods 7:00 - 9:00 AM, 11:30 AM – 1:30 PM, and 4:00 – 6:00 PM. This data, along with all turning movement count output is found in Appendix B. Table 4 provides a detailed listing of each intersection count, peak hour, and count date.



Table 4. Traffic Count Information

Traffic Count Location	Period Counted	Peak Hour	Date of Count
Estes Drive Extension and Seawell School Road	AM Peak	7:40 – 8:40 AM	11/14/17
	Noon Peak	12:05 – 1:05 PM	
	PM Peak	4:55 – 5:55 PM	
Estes Drive Extension and UNC Student RR Lot	AM Peak	7:40 – 8:40 AM	11/14/17
	Noon Peak	12:05 – 1:05 PM	
	PM Peak	4:35 – 5:35 PM	
Estes Drive Extension and Airport Drive	AM Peak	7:40 – 8:40 AM	11/14/17
	Noon Peak	12:05 – 1:05 PM	
	PM Peak	4:35 – 5:35 PM	
Estes Drive Extension / Estes Drive and NC 86 (Martin Luther King, Jr. Boulevard)	AM Peak	7:30 – 8:30 AM	11/14/17
	Noon Peak	12:15 – 1:15 PM	
	PM Peak	4:55 – 5:55 PM	
NC 86 (Martin Luther King, Jr. Boulevard) and Airport Drive	AM Peak	7:35 – 8:35 AM	11/14/17
	Noon Peak	11:45 – 12:45 PM	
	PM Peak	4:45 – 5:45 PM	

Traffic count information shows traffic flows on N.C. 86 (Martin Luther King, Jr. Boulevard) were heavy during the AM and PM peak count periods, with southbound flows into downtown Chapel Hill heaviest in the AM peak and northbound return flows heaviest in the PM peak. Traffic on Estes Drive and the Estes Drive Extension was moderate to heavy during the peak commuting periods. Traffic flows were light to moderate on the remaining study area roadways that function as collector or local access streets.

Turning movement counts were also collected on November 14, 2017 in the field for the two existing driveways serving the Chapel Hill Police Station along NC 86 (Martin Luther King, Jr. Blvd) just south of the project study area. Turning movements entering and exiting the site were compiled for the peak hours corresponding to highest adjacent street traffic for use in trip generation estimation in **Section II. C** of this report. Raw count data for the driveways is also found in **Appendix B**.

II. FUTURE BUILD-OUT YEAR CONDITIONS

A. Future Ambient Area-Wide Traffic Growth Estimation

Based on information on average daily traffic collected by the Town of Chapel Hill and the NCDOT, a yearly ambient traffic growth rate of 1.0 percent per year was used for the short-term 2021 design year capacity analyses. This rate is based on previous and anticipated growth trends for this area from Town and NCDOT average daily traffic information from the period 2003-2015, and is generally consistent with recent traffic impact studies near the project study area. **Figure 8** shows ambient area-wide growth traffic volume projections.

B. Approved Background Development Traffic Estimation

Per information from Town of Chapel Hill staff and the Town’s Development Activity Report, five potential future developments that are either currently in the concept plan phase, approved, under construction, or are expected to be built out and fully operational by the 2021 design analysis year were studied for the



inclusion of specific background traffic for this report. The five developments are listed in Table 5, along with their current status and impact to 2021 traffic volumes.

Table 5. Study Area Background Development Status

Development Name	Fall 2017 Status	Development Density	TIS Status	2021 Traffic Impact
Chapel Hill Retirement Residences	Approved, Not Constructed	100 Units	No - Exempt	Assume 100% built out – specific generator
Sawmill Condominiums	Concept Plan Phase	150 Units	No	Assume 100% built out – specific generator
North Estes Mixed-Use Center	Concept Plan Phase	100k SF Office 100k SF Retail	Yes – RS&H (2012) – Older Concept Plan	Assume Build-Out Post 2021
Women’s Health & Wellness Center	Approved, Not Constructed	25k SF Redevelopment	No	Assume Included in Ambient Growth Projections
Carolina North	Approved, No Major Anticipated Near-Term Activity	Phase 1	Yes – VHB (2009)	Assume Any Impact Between 2017 and 2021 Included in Ambient Growth Projections

Figure 9 shows the relative location of the background developments listed in Table 5. Total estimated background traffic volumes for the two background generators assumed to be complete by the 2021 analysis year in the project study area are shown in Figure 10. Figure 11 shows the total background peak hour traffic volumes estimated for the 2021 Without Site analysis scenario. These volumes include the projected ambient area-wide traffic growth and the specific background generator estimates displayed in Figure 10.

Appendix C displays individual background traffic generator peak hour volumes estimates projected across the project study area. Traffic assignment from the two specific generator developments was estimated based on development density information and/or trip generation data provided for the Chapel Hill Retirement Residences and the Sawmill Condominiums projects. Background traffic assignment in the project study area was determined by using current turning movement peak hour volumes and engineering judgment.

C. Proposed Project Traffic

i. Trip Generation

Projected trips for the proposed government services facility expansion were generated based on the ITE Trip Generation Manual (Institute of Transportation Engineers, 9th Edition, 2013) and supplemented with field traffic count data for the existing Chapel Hill Police Station on NC 86 (Martin Luther King, Jr Blvd). Trip generation methodologies for estimated trips utilize the number of dwelling units and average rate methodology (per NCDOT recommendations) as trip-generating variables. Table 6 shows the number of vehicular trips generated by existing Town of Chapel Hill Municipal Services Campus during the weekday AM, noon, and PM peak hours of adjacent streets, based on the generation methodologies described above. A peak hour truck percentage of two percent was estimated for all site-generated traffic.



Table 6
Phase 1 Weekday Peak Hour Vehicle Trip Generation Summary

ITE LUC	Description	Density	Daily			AM Peak			Noon Peak			PM Peak		
			Enter	Exit	Total	Enter	Exit	Total	Enter	Exit	Total	Enter	Exit	Total
710	General Office Building	48,467 SF	379	379	758	94	13	107	59**	62**	121**	23	110	133
N/A	Police Station – Field Data Adjusted	24,346 SF	146	146	292	32	3	35	28	22	50	15	40	55
Total Phase 1		72,813 SF	525	525	1,050	126	16	142	87	84	171	38	150	188

** - No ITE Data Available for Noon Peak Hour, Data is Average of AM and PM Results

ii.) Adjustments to Trip Generation Rates

Raw ITE trip generation estimates for daily and peak hour trips are typically adjusted for the following factors to reduce raw trip generation estimates to actual estimated vehicular trips produced by the Town of Chapel Hill Municipal Services Campus development.

a.) Internal Capture

The land uses proposed for Town of Chapel Hill Municipal Services Campus development would not exhibit the potential for internally captured trips for any on-site uses. No additional modifications or reductions were made to trip generation results to account for internal capture.

b.) Modal Split

The study area is well served by several CHT and Triangle Transit fixed bus routes with frequent existing service with connectivity to trip attractions in downtown Chapel Hill and the UNC Main Campus, although most routes are not currently easily accessible from the site parcel. Likewise, pedestrian and bicycle facilities exist in the study area but lack connectivity to the site parcel itself currently. To be conservative, no quantitative reductions in vehicular trips was made using these modes. However, it is recognized that some peak period trip-making will occur with the availability and potential future connectivity provided for non-motorized transportation.

c.) Pass-by Trips

No pass-by trips were accounted for in this study, since the proposed Town of Chapel Hill Municipal Services Campus is not a typical pass-by trip generator.

d.) Trip Generation Budget

Current plans for Town of Chapel Hill Municipal Services Campus are for the project to be built in multiple phases, but only Phase 1 is included in this analysis. Additional phases are not explicitly defined in terms of development densities or schedules, so this analysis will need to be updated when plans for those future phases are complete.

iii.) Trip Distribution

Trip distribution for site-related traffic was based existing daily and peak hour traffic patterns to determine the directional peak hour characteristics of traffic to and from the site from the major study area thoroughfares. No local trips to/from lower volume collector and residential streets were estimated, though the possibility exists a small portion of trip-making may occur to/from these local streets. Basic distribution estimates for site traffic flow utilized existing peak hour turning movement counts and overall comparison to local and regional trip attractors. Distribution estimates for the two



site driveways were based on assumptions of utilization of the closest driveway and adjacent proposed parking facilities to the Phase 1 site building. **Figure 12** presents the projected trip distribution traffic percentages for the proposed site in 2021.

iv.) Trip Assignment

Figure 13 shows the corresponding Phase 1 site traffic volumes distributed on the 2021 study area network. Total volumes into and out of the site correspond to total external vehicular trips generated, based on the trip generation methodology developed previously.

D. Future Traffic Forecasts with the Proposed Development

Figure 14 displays the 2021 Build-out+1 year projected study area traffic volumes with site traffic added. These traffic volumes represent the aggregate traffic growth over existing traffic volumes for a) ambient traffic growth, b) specific background development traffic assignments from those developments, and c) estimated site traffic assignment for Phase 1 of the Town of Chapel Hill Municipal Services Campus. **Appendix D** contains all the peak hour scenario volume development spreadsheets used in the estimation of 2021 traffic volumes for both the with and without site scenarios.

III. IMPACT ANALYSES

A. Peak Hour Intersection Level of Service Analysis

i.) Methodology

Evaluation of traffic operations on suburban arterial, collector, and local roadway facilities is most effective through the determination of level of service (LOS) criteria. The concept of level of service correlates qualitative aspects of traffic flow to quantitative terms. This enables transportation professionals to take the qualitative issues, such as congestion and substandard geometrics, and translate them into measurable quantities, such as operating speeds and vehicular delays. The 2010 *Highway Capacity Manual (HCM 2010)* characterizes level of service by letter designations A through F. Level of service A represents ideal low-volume traffic operations, and level of service F represents over-saturated high-volume traffic operations. Level of service is measured differently for various roadway facilities, but in general, level of service letter designations are described in **Table 7**.

The minimum acceptable peak hour intersection level of service established for this project is LOS D for signalized intersections or LOS E for critical movements at unsignalized intersections, or no increase in delay for signalized intersections operating below LOS D or unsignalized intersection critical movements operating below LOS E without the inclusion of site traffic. The following four conditions were evaluated:

Condition 1 - Existing Traffic

Condition 2 - 2021 Traffic without Site Traffic

Condition 3 - 2021 Traffic with Phase 1 Site Traffic Volumes Added

Condition 4 - 2021 Traffic with Phase 1 Site Traffic and Improvements



Table 7. Level of Service (LOS) Characteristics

Level of Service Description	Per Vehicle Delay at Signal	Per Vehicle Delay at Stop Sign
LOS A ➤ Free flow ➤ Freedom to select desired speed and to maneuver is extremely high ➤ General level of comfort and convenience for motorists is excellent	< 10.0 sec	< 10.0 sec
LOS B ➤ Stable flow ➤ Other vehicles in the traffic stream become noticeable ➤ Reduction in freedom to maneuver from LOS A	10.0 – 20.0 sec	10.0 – 15.0 sec
LOS C ➤ Stable flow ➤ Maneuverability and operating speed are significantly affected by other vehicles ➤ General level of comfort and convenience declines noticeably	20.0 – 35.0 sec	15.0 – 25.0 sec
LOS D ➤ High density but stable flow ➤ Speed/freedom to maneuver are very restricted ➤ General level of comfort / convenience is poor ➤ Small increases in traffic will generally cause operational problems	35.0 – 55.0 sec	25.0 – 35.0 sec
LOS E ➤ Unstable flow ➤ Speed reduced to lower but relatively uniform value ➤ Volumes at or near capacity level ➤ Comfort and convenience are extremely poor ➤ Small flow increases or minor traffic stream disturbances will cause breakdowns	55.0 – 80.0 sec	35.0 – 50.0 sec
LOS F ➤ Forced or breakdown flow ➤ Volumes exceed roadway capacity ➤ Formation of unstable queues ➤ Stoppages for long periods of time because of traffic congestion	> 80.0 sec	> 50.0 sec

The *Synchro Professional Version 9* operations analysis software was used to analyze peak hour conditions at signalized intersections. Synchro was also used to analyze peak hour conditions at unsignalized intersections, through the use of its HCM 2010 two-way stop controlled output function. The methodology of evaluating each condition for signalized intersections is presented below:

- **Condition 1** – Use current Town of Chapel Hill data for the cycle length, splits and offsets of individual signalized intersections and report LOS and delay values from Synchro.
- **Conditions 2 and 3** – Reoptimize the cycle lengths and splits of individual intersections in Synchro, if existing timing data does not provide adequate overall intersection LOS. Adjust cycle lengths, splits, and offsets, if necessary, if the signal is currently operating in a coordinated system. The optimized signal timing information will be held constant for both Conditions, to provide a means to compare effects of the proposed site traffic. No changes to free run traffic signal inputs were made for Conditions 2 and 3.



- **Condition 4** – Optimize coordinated traffic signals for effects of recommended mitigation strategies that change existing/committed changes to lane geometrics. Evaluate the potential for different signal phasing schemes (left-turn lag phases, for example). Retain existing split minimums and any pedestrian timing values. Recommendations, if warranted, will be made to obtain at least LOS D for the intersection as a whole.

The net effect of this process is that direct comparisons, by movement, of delay and LOS between each of the three conditions are impossible because splits and cycle lengths can and do change between conditions. The pertinent statistic of this analysis is the *overall intersection level of service and delay*. Improvements to deficient intersections in Condition 3 were made by first attempting to adjust signal operations via changes in cycle lengths, splits and/or with acceptable adjustments to signal phasing. If that did not produce satisfactory results for all intersections, geometric improvements to improve intersection capacity were considered for the deficient intersections. **Appendix E** contains the Synchro signalized intersection output for all four conditions (where applicable).

Unsignalized intersections were analyzed using HCM methodologies. Their results were evaluated on a per-movement basis, since HCM methods do not produce an overall intersection level of service for unsignalized intersections. Thus, intersections with deficient (LOS F) movements in Condition 2 would need to be evaluated for improvements in Condition 3. This methodology differs from signalized intersections, where one or more movements at an intersection may be deficient in Condition 2, but as long as the overall intersection level of service does not fall below LOS D, no intersection improvements may be deemed necessary. **Appendix F** contains the Synchro 2010 HCM unsignalized output for all stop-controlled intersections under study.

ii.) 2017 Existing Conditions Results

Table 8 presents the results for the existing year traffic conditions as compiled from field data. The table lists LOS and delay values for those movements that are in existence at this time. Currently, all study area signalized intersections operate at an overall acceptable level of service for all of the analyzed 2017 peak hours, with the exception of NC 86 and Estes Drive, which operates at a LOS E in the 2017 PM peak hour. The stop-controlled approaches along Airport Drive with its intersections with Estes Drive Extension and NC 86 also operate at a deficient LOS F in at least one peak hour in 2017.

iii.) 2021 No-Build Scenario (Condition 2) Results

Table 9 presents the results for the 2021 analysis year estimated traffic conditions without the impacts of site-related traffic. This analysis includes ambient growth, and data for the future background site developments.

During Condition 2 - 2021 Without Site Traffic, delays marginally increase for most study area intersections/critical movements, with the same deficient LOS F stop-controlled approaches anticipated for Airport Drive intersections with Estes Drive Extension and NC 86. There were specific geometric improvements to the NC 86 and Estes Drive intersection area that are committed by the Town/NCDOT project to improve the Estes Drive corridor to the east. For traffic capacity analysis inputs, these are primarily auxiliary lane improvements to the intersection along with signal phasing and timing upgrades. These upgrades provide minor beneficial effects in terms of LOS and delay improvements, though they do mitigate the effect of additional projected background traffic to some extent. The NC 86 and Estes Drive intersection still is expected to operate at an overall LOS E in the 2021 PM peak hour in this scenario.



**Table 8. Capacity Analysis Results for Study Area Intersections
Condition 1 – 2017 Existing Traffic**

Intersections/Movements	LOS			Average Vehicular Delay (seconds/vehicle)		
	AM	Noon	PM	AM	Noon	PM
Estes Drive Extension and Seawell School Road	B	A	B	15.0	9.9	17.5
SB LT	C	B	C	23.5	18.7	30.3
SB RT	C	B	D	25.3	19.6	37.4
EB LT	A	A	A	9.3	4.5	8.3
EB THRU	B	A	A	11.6	5.4	6.4
WB THRU	B	B	C	19.5	12.9	23.6
WB RT	A	A	A	3.9	3.3	3.1
Estes Drive Extension and UNC Student RR Lot	N/A	N/A	N/A	N/A	N/A	N/A
EB LT	A	A	A	8.1	8.2	9.4
SB LT	C	C	D	22.8	16.7	29.9
SB RT	A	A	B	0.0	0.0	14.3
Estes Drive Extension and Airport Drive	N/A	N/A	N/A	N/A	N/A	N/A
WB LT	B	A	A	10.3	8.2	8.5
NB LT-RT	C	B	F	24.8	14.9	50.7
Estes Drive Extension / Estes Drive and NC 86 (Martin Luther King, Jr. Boulevard)	D	D	E	44.1	39.7	61.8
EB LT	D	E	F	51.3	59.3	109.2
EB THRU	E	E	E	78.0	79.4	57.2
EB RT	D	D	D	36.3	47.3	38.2
WB LT	D	D	D	47.4	52.5	42.5
WB THRU	E	F	F	55.5	91.9	126.3
WB RT	C	D	F	20.2	43.1	96.4
NB LT	D	C	C	40.7	23.2	32.1
NB THRU-RT	D	C	D	42.7	26.5	45.4
SB LT	D	C	F	40.1	25.2	98.7
SB THRU-RT	D	B	C	37.4	18.7	31.1
NC 86 (Martin Luther King, Jr. Boulevard) and Airport Drive	N/A	N/A	N/A	N/A	N/A	N/A
EB LT	F	D	F	58.1	28.6	67.4
EB RT	C	B	B	16.6	11.2	11.8
NB LT	B	A	A	13.2	9.5	9.9

N/A => Not Applicable, i.e. movement is non-existent or overall intersection values are not reported for unsignalized intersections
BOLD/ITALICS – Movement or overall intersection is over Town TIS Guidelines threshold capacity



Table 9. Capacity Analysis Results for Study Area Intersections
Condition 2 – 2021 Traffic Without Site

Intersections/Movements	LOS			Average Vehicular Delay (seconds/vehicle)		
	AM	Noon	PM	AM	Noon	PM
Estes Drive Extension and Seawell School Road	B	B	B	15.5	10.1	18.6
SB LT	C	B	C	24.6	19.3	31.7
SB RT	C	C	D	26.4	20.3	39.5
EB LT	A	A	A	9.8	4.5	9.2
EB THRU	B	A	A	12.1	5.4	6.5
WB THRU	B	B	C	19.6	12.9	24.3
WB RT	A	A	A	3.8	3.2	3.0
Estes Drive Extension and UNC Student RR Lot	N/A	N/A	N/A	N/A	N/A	N/A
EB LT	A	A	A	8.1	8.3	9.5
SB LT	D	C	D	32.2	17.5	32.6
SB RT	A	A	B	0.0	0.0	14.7
Estes Drive Extension and Airport Drive	N/A	N/A	N/A	N/A	N/A	N/A
WB LT	B	A	A	10.5	8.3	8.6
NB LT-RT	D	C	F	27.0	15.5	65.3
Estes Drive Extension / Estes Drive and NC 86 (Martin Luther King, Jr. Boulevard)	D	D	E	42.7	40.8	59.9
EB LT	<i>E</i>	<i>E</i>	<i>F</i>	71.7	78.5	107.6
EB THRU	<i>E</i>	<i>E</i>	<i>E</i>	64.9	55.7	56.9
EB RT	C	C	D	22.3	33.3	38.4
WB LT	<i>E</i>	<i>E</i>	<i>F</i>	70.4	77.1	92.2
WB THRU	<i>F</i>	<i>E</i>	<i>F</i>	80.1	76.7	106.1
WB RT	C	C	D	30.5	25.8	54.3
NB LT	C	D	D	23.2	38.5	44.5
NB THRU	D	D	<i>E</i>	40.8	40.2	65.1
NB RT	B	B	B	15.7	15.9	17.6
SB LT	C	C	<i>F</i>	27.5	33.6	90.5
SB THRU	D	C	C	37.8	25.7	33.6
SB RT	A	B	B	5.4	10.7	12.9
NC 86 (Martin Luther King, Jr. Boulevard) and Airport Drive	N/A	N/A	N/A	N/A	N/A	N/A
EB LT	<i>F</i>	D	<i>F</i>	68.4	32.4	87.5
EB RT	C	B	B	17.7	11.4	12.1
NB LT	B	A	B	14.0	9.7	10.2

N/A => Not Applicable, i.e. movement is non-existent or overall intersection values are not reported for unsignalized intersections
BOLD/ITALICS – Movement or overall intersection is over Town TIS Guidelines threshold capacity
BLUE = New or Modified Movements Committed in No Build Scenario

Iv.) 2021 Build Scenario (Condition 3) Results

Table 10 presents results for 2021 Build-out+1 year estimated traffic conditions, including impacts of site-related traffic. In general, the addition of site-related traffic will marginally increase delays at existing intersections and is not expected to cause additional intersections or critical intersection stop-controlled movements to drop to deficient levels in the 2021 analysis year.



**Table 10. Capacity Analysis Results for Study Area Intersections
Condition 3 – 2021 Traffic With Site (Phase 1)**

Intersections/Movements	LOS			Average Vehicular Delay (seconds/vehicle)		
	AM	Noon	PM	AM	Noon	PM
Estes Drive Extension and Seawell School Road	B	B	B	15.6	10.1	18.7
SB LT	C	B	C	25.1	19.5	32.3
SB RT	C	C	D	26.6	20.4	40.1
EB LT	A	A	A	9.7	4.5	9.4
EB THRU	B	A	A	12.2	5.4	6.5
WB THRU	B	B	C	19.5	13.0	24.3
WB RT	A	A	A	3.8	3.2	3.1
Estes Drive Extension and West Site Driveway / UNC Student RR Lot	N/A	N/A	N/A	N/A	N/A	N/A
EB LT	A	A	A	8.1	8.3	9.5
WB LT	B	A	A	10.2	8.4	8.6
NB LT-THRU-RT	C	B	C	23.6	13.8	20.2
SB LT	E	C	E	46.2	21.8	47.0
SB THRU-RT	A	A	B	0.0	0.0	14.8
Estes Drive Extension and East Site Driveway	N/A	N/A	N/A	N/A	N/A	N/A
WB LT	B	A	A	10.9	8.6	8.9
NB LT	E	C	E	43.3	22.7	39.9
NB RT	C	B	B	17.1	12.0	14.9
Estes Drive Extension and Airport Drive	N/A	N/A	N/A	N/A	N/A	N/A
WB LT	B	A	A	10.6	8.5	9.1
NB LT-RT	E	C	F	42.6	20.2	134.3
Estes Drive Extension / Estes Drive and NC 86 (Martin Luther King, Jr. Boulevard)	D	D	E	43.1	42.3	62.5
EB LT	E	E	F	71.7	78.9	130.5
EB THRU	E	D	E	64.8	53.3	57.8
EB RT	C	C	D	21.9	32.5	39.8
WB LT	E	E	F	68.9	77.1	92.2
WB THRU	F	E	F	84.4	76.2	107.8
WB RT	C	C	D	29.6	24.6	53.4
NB LT	C	D	D	27.4	41.4	46.8
NB THRU	D	D	E	41.5	42.6	66.8
NB RT	B	B	B	15.8	17.1	17.8
SB LT	C	D	F	28.2	37.6	90.9
SB THRU	D	C	C	39.2	29.1	34.0
SB RT	A	B	B	5.8	12.2	13.2
NC 86 (Martin Luther King, Jr. Boulevard) and Airport Drive	N/A	N/A	N/A	N/A	N/A	N/A
EB LT	F	E	F	81.9	37.6	106.1
EB RT	C	B	B	17.9	11.8	12.9
NB LT	B	A	B	14.8	10.0	10.5

N/A => Not Applicable, i.e. movement is non-existent or overall intersection values are not reported for unsignalized intersections
BOLD/ITALICS – Movement or overall intersection is over Town TIS Guidelines threshold capacity
BLUE = New or Modified Movements Committed in Build Scenario



v.) 2021 Build + Mitigation Scenario (Condition 4) Results

Table 11 presents results for 2021 Build-out+1 year estimated traffic conditions, including impacts of site-related traffic and safety-related recommended mitigation improvements along the Estes Drive Extension. These improvements include the development of a three-lane undivided cross-section from the existing UNC RR Lot intersection to NC 86 (Martin Luther King, Jr Blvd), which would provide a continuous two-way left-turn lane at each existing or proposed intersection. In addition, an additional eastbound left-turn lane was tested at the NC 86 intersection with Estes Drive/Estes Drive Extension. The Town has committed to including this improvement in the Estes Drive pedestrian and bicycle improvements project.

**Table 11. Capacity Analysis Results for Study Area Intersections
Condition 4 – 2021 Traffic With Site & Mitigation**

Intersections/Movements	LOS			Average Vehicular Delay (seconds/vehicle)		
	AM	Noon	PM	AM	Noon	PM
Estes Drive Extension and West Site Driveway / UNC Student RR Lot	N/A	N/A	N/A	N/A	N/A	N/A
EB LT	A	A	A	8.1	8.3	9.5
WB LT	B	A	A	10.2	8.4	8.6
NB LT-THRU-RT	C	B	C	23.6	13.8	20.1
SB LT	E	C	E	45.7	21.7	46.5
SB THRU-RT	A	A	B	0.0	0.0	14.8
Estes Drive Extension and East Site Driveway	N/A	N/A	N/A	N/A	N/A	N/A
WB LT	B	A	A	10.9	8.6	8.9
NB LT	C	C	C	20.7	15.5	20.1
NB RT	C	B	B	17.1	12.0	14.9
Estes Drive Extension and Airport Drive	N/A	N/A	N/A	N/A	N/A	N/A
WB LT	B	A	A	10.6	8.5	9.1
NB LT-RT	C	C	D	22.6	15.1	30.9
Estes Drive Extension / Estes Drive and NC 86 (Martin Luther King, Jr. Boulevard)	D	D	D	40.1	39.7	54.0
EB LT	E	E	F	56.6	74.2	98.0
EB THRU	E	E	E	68.0	66.6	68.8
EB RT	C	D	D	23.3	39.6	45.9
WB LT	E	E	F	72.8	75.3	92.2
WB THRU	E	E	F	72.6	75.9	93.3
WB RT	C	C	D	28.1	30.8	45.5
NB LT	C	C	D	24.7	30.7	40.4
NB THRU	D	C	E	38.3	31.9	55.5
NB RT	B	B	B	14.9	11.8	15.2
SB LT	C	C	E	25.7	31.4	73.5
SB THRU	D	C	C	36.2	23.6	28.3
SB RT	A	B	B	6.9	12.4	14.9

N/A => Not Applicable, i.e. movement is non-existent or overall intersection values are not reported for unsignalized intersections
BLUE = New or Modified Movements Analyzed in Mitigation Scenario

B. Access Analysis

Vehicular site access is to be accommodated at two proposed full movement access driveways connecting to Estes Drive Extension. The western site driveway is about 800 feet to the east of the Estes



Drive Extension signalized intersection with Seawell School Road. As conceptually shown in **Figure 2**, the driveways have single inbound lanes. The western driveway is assumed to have one outbound lane, with the eastern (main) driveway assumed to have two outbound lanes. The driveway connections to the Estes Drive Extension have throat lengths of approximately 150 feet (eastern) and 500 feet (western) prior to internal parking lot connections. Throat lengths are acceptable, based on 50 foot minimum throat length standards found on Page 69 of the 2017 *Town of Chapel Hill Public Works Design Manual*.

Driveway distances along Estes Drive Extension from the signalized intersection at Seawell School Road is approximately 800 feet as noted above, and is acceptable, based on recommendations of 100 foot minimum corner clearance as set forth in the 2003 *NCDOT Policy on Street and Driveway Access to North Carolina Highways* and the 100 foot minimum along collector streets specified in the Town Design Manual. The distance between the proposed driveway connections is approximately 600 feet and would also be acceptable, based on the recommended 50 foot spacing between driveways along collector roadways found in Table 3.2 – Street Standards in the Town Design Manual.

Access for pedestrians and bicycles is not adequate in the project study area. Sidewalk is present along the NC 86 corridor and along sections of Seawell School Road and Estes Drive to the east of NC 86. Crosswalk exists across the Estes Drive intersection with the NC 86 signalized intersection in only one quadrant. No specific bicycle amenities are present along the Estes Drive Extension, but bicycle “sharrow” lanes are present along NC 86 south of the Estes Drive Extension. With the completion of the pedestrian and bicycle projects along Estes Drive and the Estes Drive Extension, pedestrian and bicycle access to the site will improve significantly, as continuous facilities for both modes will be constructed along over two miles of the Estes Drive/Estes Drive Extension corridor.

C. Signal Warrant Analysis

Based on projected 2021 traffic volumes and proposed access plans, the unsignalized Site Driveway intersections with the Estes Drive Extension would not warrant the installation of a traffic signal, based on the methodology found in the 2009 *Manual on Uniform Traffic Control Devices (MUTCD)*.

The stop-controlled approaches at the intersections of Estes Drive Extension and Airport Drive and NC 86 and Airport Drive are expected to operate at a LOS F in the 2021 analysis year with site traffic added. 2021 peak hour volumes and existing geometrics at these locations were analyzed for meeting the Peak Hour Warrant in the 2009 MUTCD and HCS Warrants software package. The results shown in **Appendix G** indicate that the Estes Drive and Airport Drive intersection would warrant the installation of a traffic signal, but the NC 86 and Airport Drive intersection would not, based on only the Peak Hour Warrant. Satisfaction of additional warrants would be needed to justify the implementation of a traffic signal at these locations.

D. Sight Distance Analysis

In general, sight distance issues entering/exiting the existing Town of Chapel Hill Municipal Services Campus driveways would be minimal, considering the fact that Estes Drive Extension has no horizontal curvature in the vicinity of this existing access location and vertical curvature at this location is minimal, giving entering and exiting traffic adequate sight distance in both directions.

E. Crash Analysis

Data from the NCDOT Traffic Safety Unit TEAAS crash software database was extracted for the five year period from 11/1/2012 to 10/31/2017 for the segment of the Estes Drive Extension from Seawell School Road to NC 86 (Martin Luther King, Jr. Boulevard). Raw crash data can be found in **Appendix H**.



Estes Drive Extension Corridor

There were 25 crashes reported along the Estes Drive Extension study area corridor between Seawell School Road and NC 86 over the five year period. In this 0.78 mile segment, crash types varied with no predominate crash type. Several left-turn, run-off road and rear end crash types were noted. Spatial distribution of crashes along the corridor from the segment strip map indicates that a considerable number of crashes (16) occurred in the vicinity of the NC 86 (Martin Luther King, Jr. Blvd) intersection. The remaining crashes were distributed near other intersections along the rest of the segment, with four crashes occurring in the vicinity of the Airport Drive intersection and three crashes near Seawell School Road. One fatality crash (motorcyclist) occurred at the intersection with Seawell School Road.

Table 12 presents a comparison between the Estes Drive Extension study area crash rates and the latest North Carolina statewide rates for the period 2013-2015 (compiled by NCDOT Traffic Safety Unit). Overall, the crash rates along Estes Drive Extension in the project study area are lower than statewide averages for similar facilities (two-lane undivided) in every reported category, except for fatal crashes.

Table 12. Study Area Crash Rate Comparison – Estes Drive Extension Corridor

Statistic	Crashes Per 100 Million Vehicle Miles	
	Estes Drive Extension Seawell School Rd to NC 86 (MLK Jr. Blvd)	NC Statewide Average* 2-Lane Undivided
Total Crash Rate	141.55	247.39
Fatal Crash Rate	5.66	1.18
Non-Fatal (Injury) Crash Rate	33.97	76.16
Night Crash Rate	50.96	65.51
Wet Crash Rate	45.30	46.04

* - Data for Urban Secondary Routes

F. Other Transportation-Related Analyses

Other transportation-related analyses relevant to the 2001 Town of Chapel Hill Guidelines for the preparation of Traffic Impact Studies were completed as appropriate. The following topics listed in **Table 13** are germane to the scope of this study.

G. Special Analysis/Issues Related to Project

Based on discussions with Town of Chapel Hill staff, there are no special issues or analyses beyond the ones already discussed for this proposed site.



Table 13. Other Transportation-Related Analyses

Analysis	Comment
Turn Lane Storage Requirements	Storage bay lengths at study area intersections were analyzed using Synchro and HCS 95 th percentile (max) queue length estimates for the 2021 Build Scenario. At the intersection of Estes Drive/Estes Drive Extension and NC 86 (Martin Luther King, Jr. Blvd), projected 95 th percentile queue lengths may exceed future delineated storage bay lengths as the intersection is still near/at capacity even with the assumed committed improvements to auxiliary turn lanes. Dual eastbound left-turn lanes, which would require 300 feet of dual left-turn lane storage are recommended to serve this movement and provide some improved overall intersection capacity which would benefit other movements that are projected to exceed turn bay storage lengths.
Appropriateness of Acceleration/Deceleration Lanes	The site concept plan shows no specifics related to acceleration/deceleration lanes. It is recommended that a westbound left-turn lane be constructed along Estes Drive Extension at the proposed site driveway to remove turning traffic movements from the westbound through traffic flow along Estes Drive Extension. Site traffic volumes heading eastbound to the site are expected to be low and would not require a right-turn deceleration lane. No other specific acceleration/deceleration lane issues were analyzed in the project study area.
Pedestrian and Bicycle Analysis	Existing pedestrian access and connectivity currently lacking along the Estes Drive Extension corridor adjacent to the site. With the completion of Town and NCDOT projects along Estes Drive and the Estes Drive Extension, the proposed site will have fully connected, safe and efficient pedestrian and bicycle access along those corridors. Signalized crosswalks and pedestrian signals are recommended for the NCDOT STIP project at the Seawell School Road/Estes Drive Extension intersection.
Public Transportation Analysis	Public transportation service to the study area, and to the proposed site is available, with bus stops and multiple local and regional bus routes along NC 86 in both directions and two local routes serving the Estes Drive Extension proximate to the site. It is recommended that a bus stop be constructed along the site frontage near the East Site Driveway.

IV. MITIGATION MEASURES / RECOMMENDATIONS

A. Planned Improvements

The Town of Chapel Hill in coordination with NCDOT has a pedestrian and bicycle improvement project for Estes Drive east of NC 86 (Martin Luther King, Jr. Blvd) that includes auxiliary lane improvements and pedestrian crosswalk/signal heads at the Estes Drive/NC 86 intersection. This project is expected to be complete by the 2021 site build-out+1 analysis year. As a result of the mitigation analysis for this traffic impact study, the Town is including the provision of an additional eastbound left-turn lane at the NC 86 and Estes Drive intersection into the design of the project. See **Figure 15** for details.

NCDOT also has a programmed pedestrian and bicycle facility enhancement project (STIP EB-5886) that will construct sidewalks, multi-use paths and bicycle lanes along the Estes Drive Extension facility between N. Greensboro Street in Carrboro to NC 86. This project is scheduled for construction in 2021 and it was also assumed to be complete by the 2021 analysis year in this study.



B. Background Committed Improvements

There are no specific geometric improvements to the study area roadway intersections related to background private development projects that are expected to be completed between 2017 and 2021. Several traffic impact studies for development projects in and near the study area recommended signal timing reoptimization for signalized intersections along the NC 86 (Martin Luther King, Jr. Blvd) corridor by their respective build-out years. It is assumed that signal timing reoptimization will occur for the NC 86 intersection with Estes Drive/Estes Drive Extension, due to the geometric and signal phasing upgrades expected to occur as part of the Estes Drive Pedestrian/Bicycle project.

As previously discussed, additional recommended improvements to transportation facilities in Town of Chapel Hill Municipal Services Campus project study area may occur as the Carolina North development progresses. However, any additional improvements due to Carolina North were considered post-2021 Phase 1 analysis year for the purposes of this study. The Carolina North traffic impact study will need to be revised and updated as definitive phased construction occurs during the course of the project.

C. Applicant Committed Improvements

Based on the preliminary site plans and supporting development information provided, there are no specific transportation-related improvements proposed external to the Town of Chapel Hill Municipal Services Campus site. The two proposed site driveways and initial laneage assumptions are schematically shown in **Figure 15**, based on the preliminary concept plans shown in **Figure 2**.

D. Necessary Improvements – Due to Site Impact

Based on traffic capacity analyses for the 2021 design year, and analyses of existing study area turning bay storage lengths and site access, the following improvements are recommended as being necessary for adequate transportation network operations due specifically to site transportation impact (see improvements in **Figure 16** highlighted in green).

- 1) Widen Estes Drive Extension along the length of site frontage to provide a consistent three-lane cross-section with exclusive westbound left-turns lane into the site at the two proposed site driveway intersections. This improvement improves operations for stop-controlled movements at both intersections and improves overall safety by removing the left-turn movements from the through traffic streams along the Estes Drive Extension.
- 2) Provide a bus stop and amenities for transit riders along the frontage of the proposed Municipal Services Campus.

E. Necessary Improvements – Regardless of Site Development

Based on traffic capacity analyses for the 2021 design year, and analyses of existing study area turning bay storage lengths and site access, the following improvements are recommended as being necessary for adequate transportation network operations due existing traffic congestion issues or issues arising from background traffic growth whether or not the Town Municipal Services Campus is constructed (see improvements in **Figure 16** highlighted in blue).

- 1) Widen Estes Drive Extension between the proposed site frontage and the NC 86 (Martin Luther King Jr. Blvd.) intersection to a consistent three-lane cross-section. This provides operational and safety improvements for the Airport Drive intersection with the Estes Drive Extension and should be considered in the design of the NCDOT pedestrian and bicycle improvement project along the Estes Drive Extension corridor.



Though the Estes Drive Extension intersection with Airport Drive meets MUTCD Peak Hour Signal Warrants, it is not recommended that a signal be installed at this location if the proposed recommendations to widen Estes Drive Extension to a three-lane cross-section are constructed. No additional improvements are recommended at the Airport Drive intersection with NC 86, though 2021 peak hour capacity analyses indicate a LOS F for stop-controlled left-turn movements for eastbound Airport Drive at this location. Provision of additional improvements at this intersection, along with signalizing the Airport Drive/Estes Drive Extension intersection may encourage additional cut-through traffic along the Airport Drive facility.

Appendix A – Figures

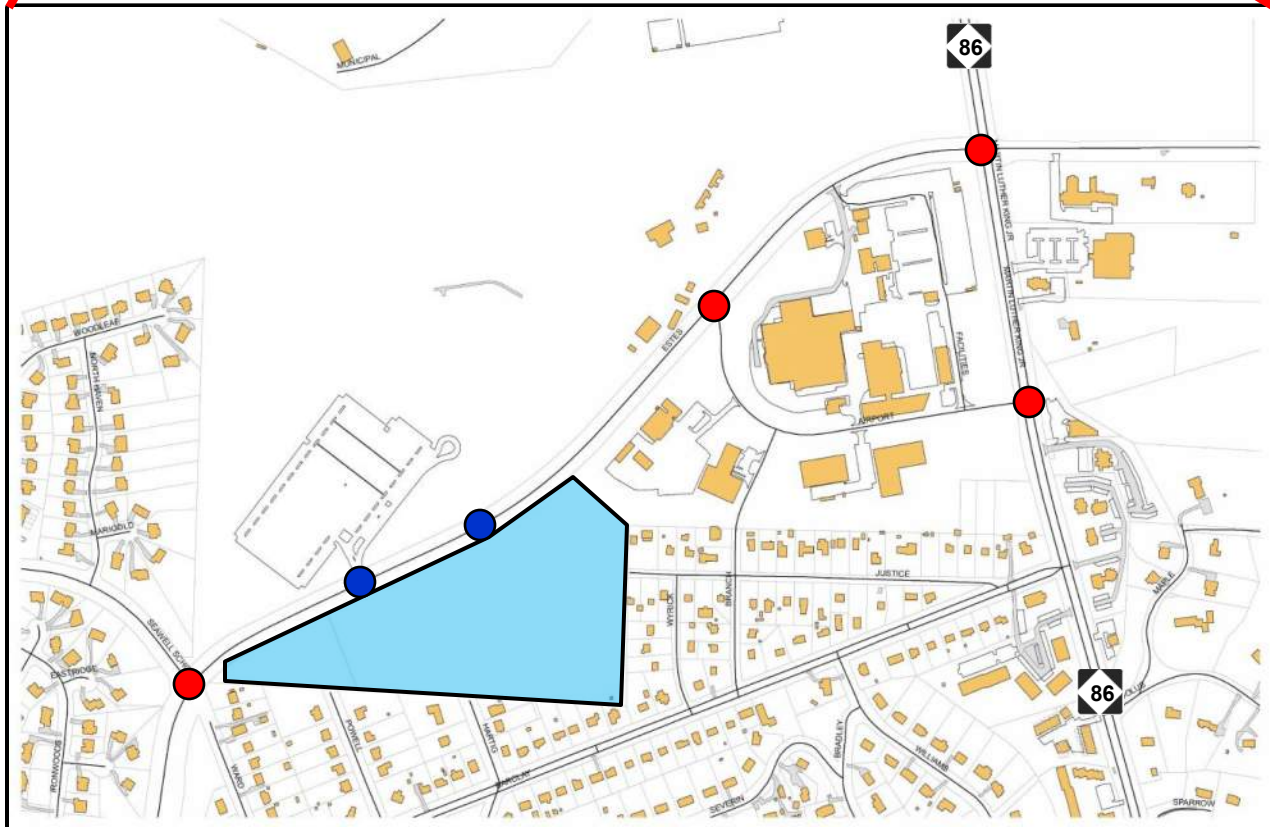
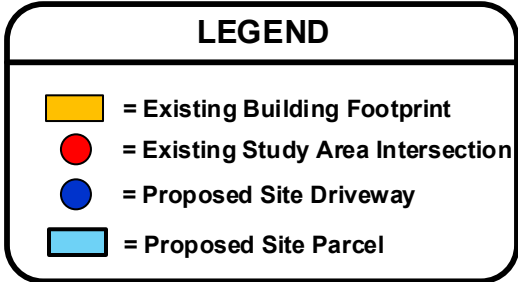
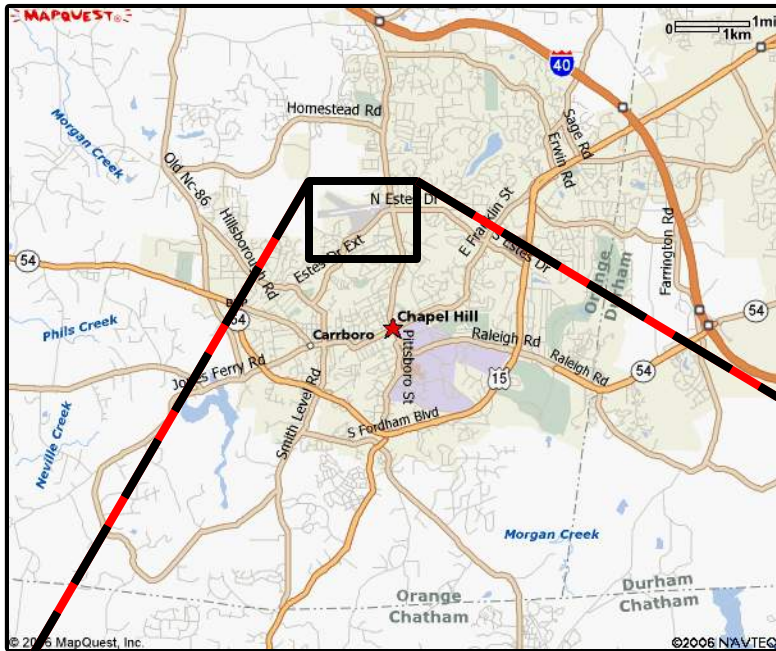

Source: Town of Chapel Hill GIS Files





**Chapel Hill Municipal Services Campus
Traffic Impact Study**

PROJECT STUDY AREA

DATE: February 2018

FIGURE 1

LEGEND

-  = PROPOSED SITE ACCESS
-  = Town Phase 1
-  = Future Phases (Not Studied)

FUTURE CAROLINA NORTH

UNC STUDENT RR LOT

ESTES DRIVE EXTENSION

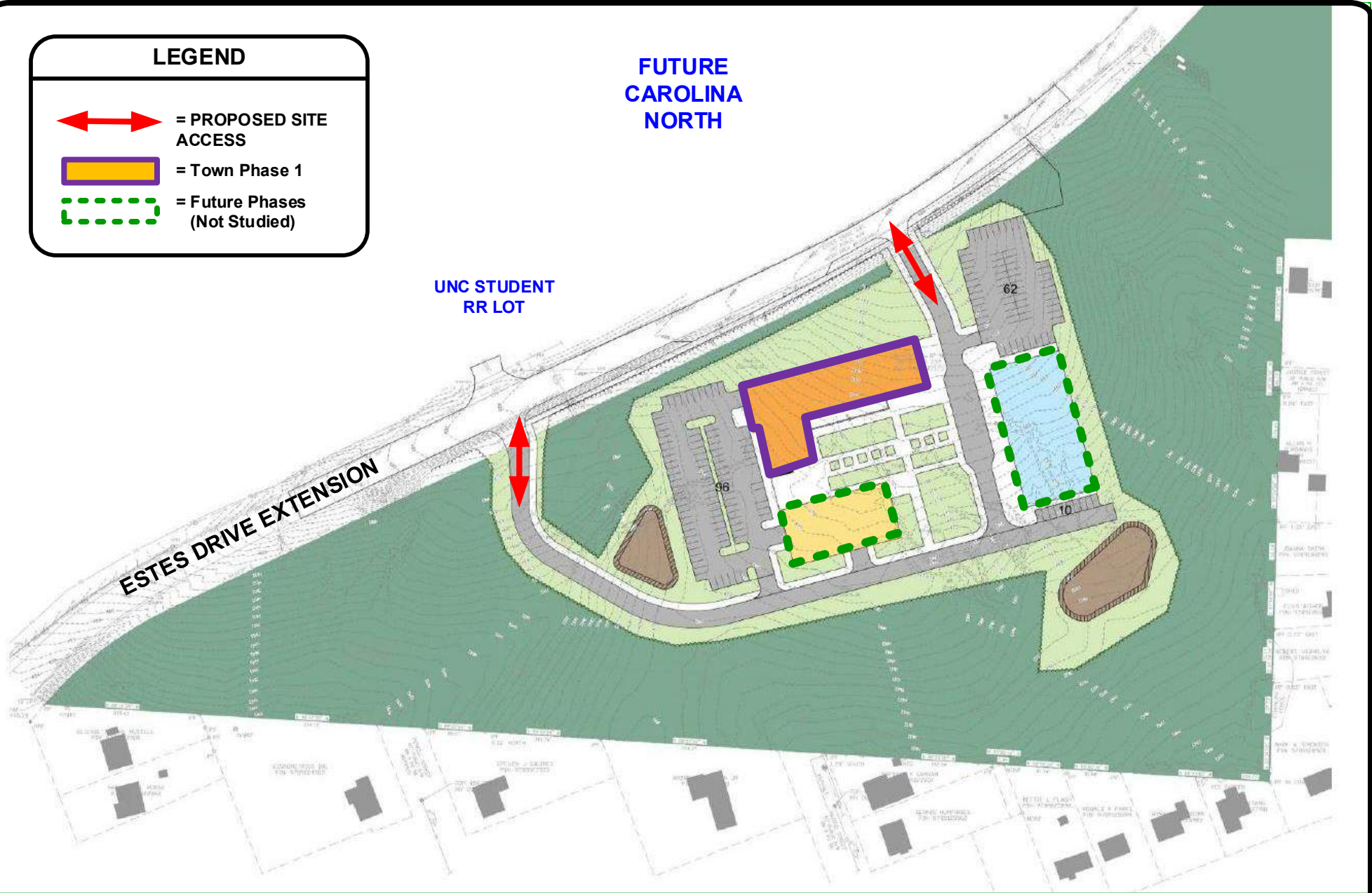

HNTB



NOT TO SCALE

**Chapel Hill Municipal Services Campus
Traffic Impact Study**

PRELIMINARY SITE PLAN

DATE: February 2018

FIGURE 2

LEGEND

Geometric, Speed Limits and
Traffic Control As Shown

XXX Storage Bay Length
CTL = Continuous Turn Lane

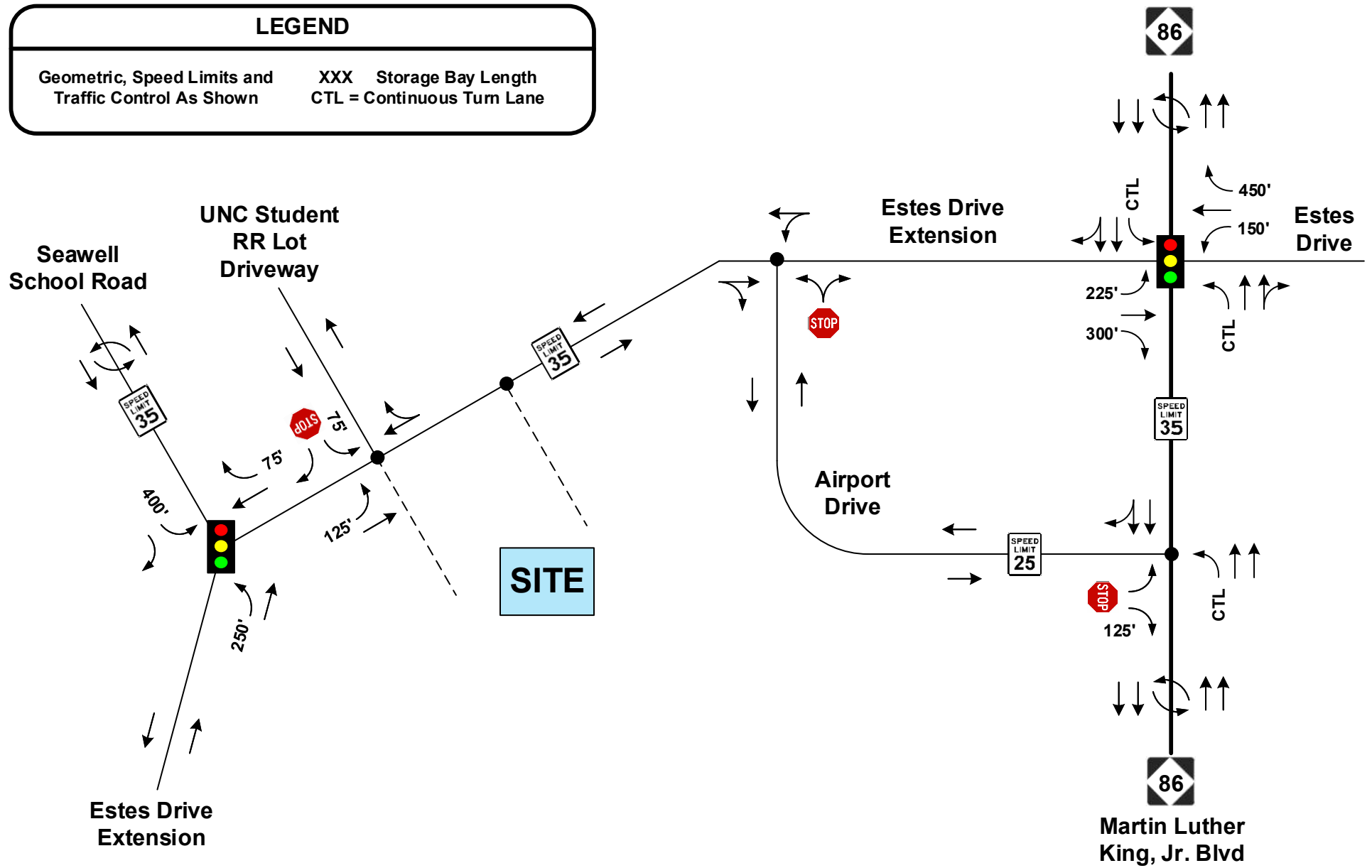

HNTB



NOT TO
SCALE

**Chapel Hill Municipal Services Campus
Traffic Impact Study**

EXISTING LANEAGE AND GEOMETRICS

DATE: February 2018

FIGURE 3

LEGEND

-  Bike Sharrows
-  Sidewalks
-  Crosswalks with pedestrian signal heads

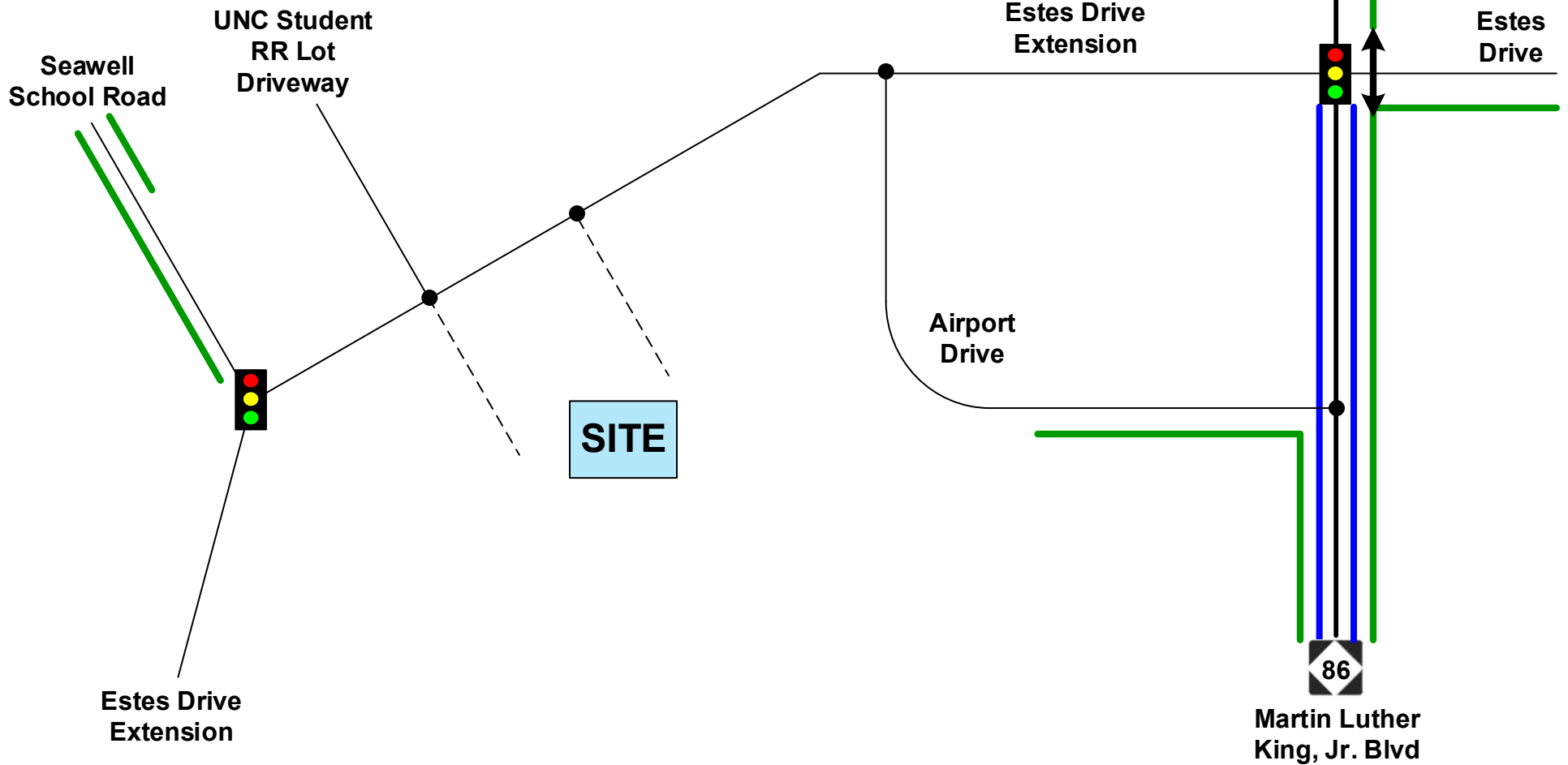

HNTB



NOT TO
SCALE

**Chapel Hill Municipal Services Campus
Traffic Impact Study**

DATE: February 2018

STUDY AREA PEDESTRIAN AND BICYCLE FACILITIES

FIGURE 4

LEGEND

- = **NS** ROUTE — = **G** ROUTE - - - = GoTriangle CRX Express
- = **T** ROUTE — = **NU** ROUTE — = GoTriangle 420
- = **A** ROUTE — = **HS** ROUTE = BUS STOP

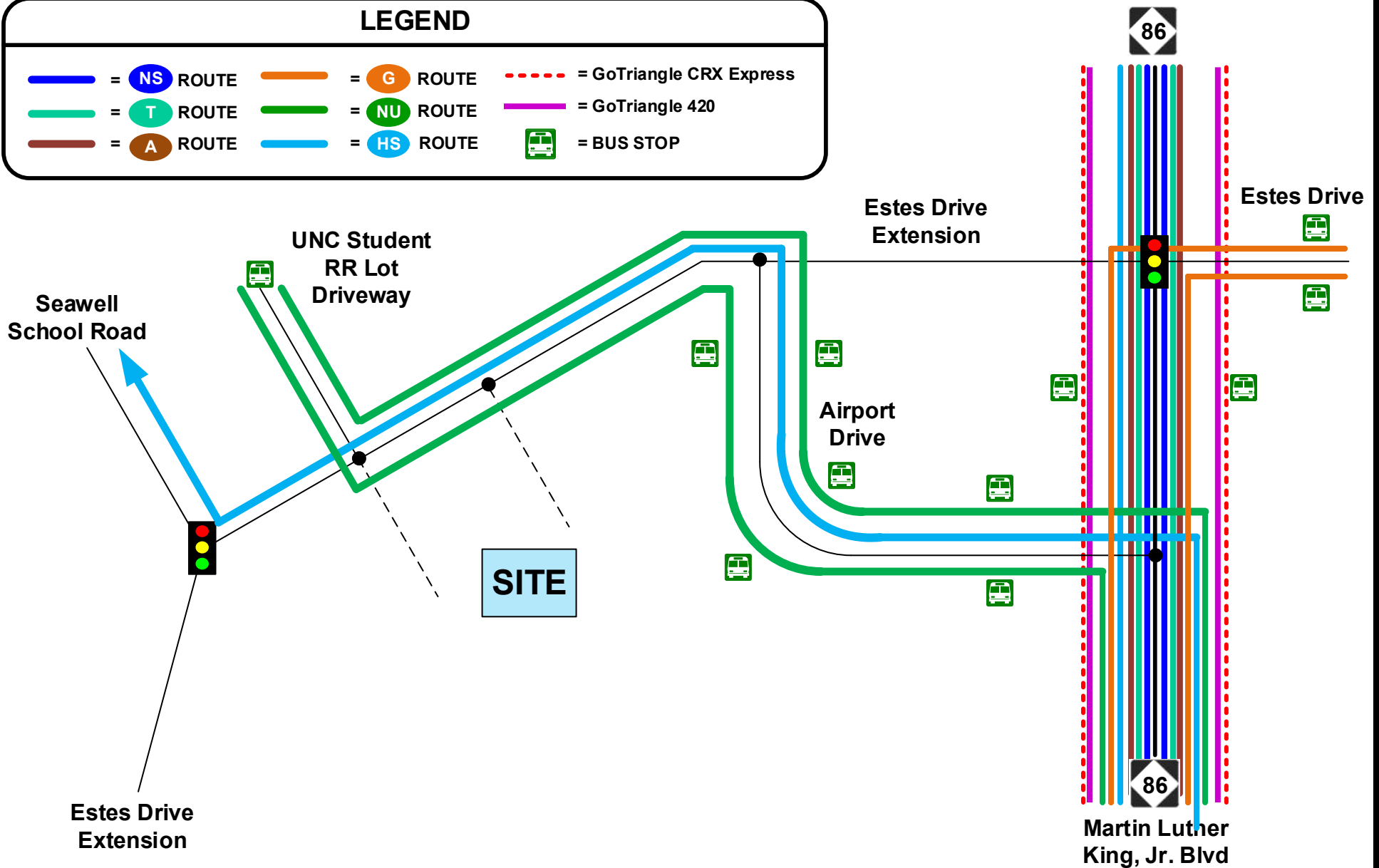

HNTB



NOT TO
SCALE

Chapel Hill Municipal Services Campus Traffic Impact Study

DATE: February 2018

STUDY AREA TRANSIT ROUTES

FIGURE 5

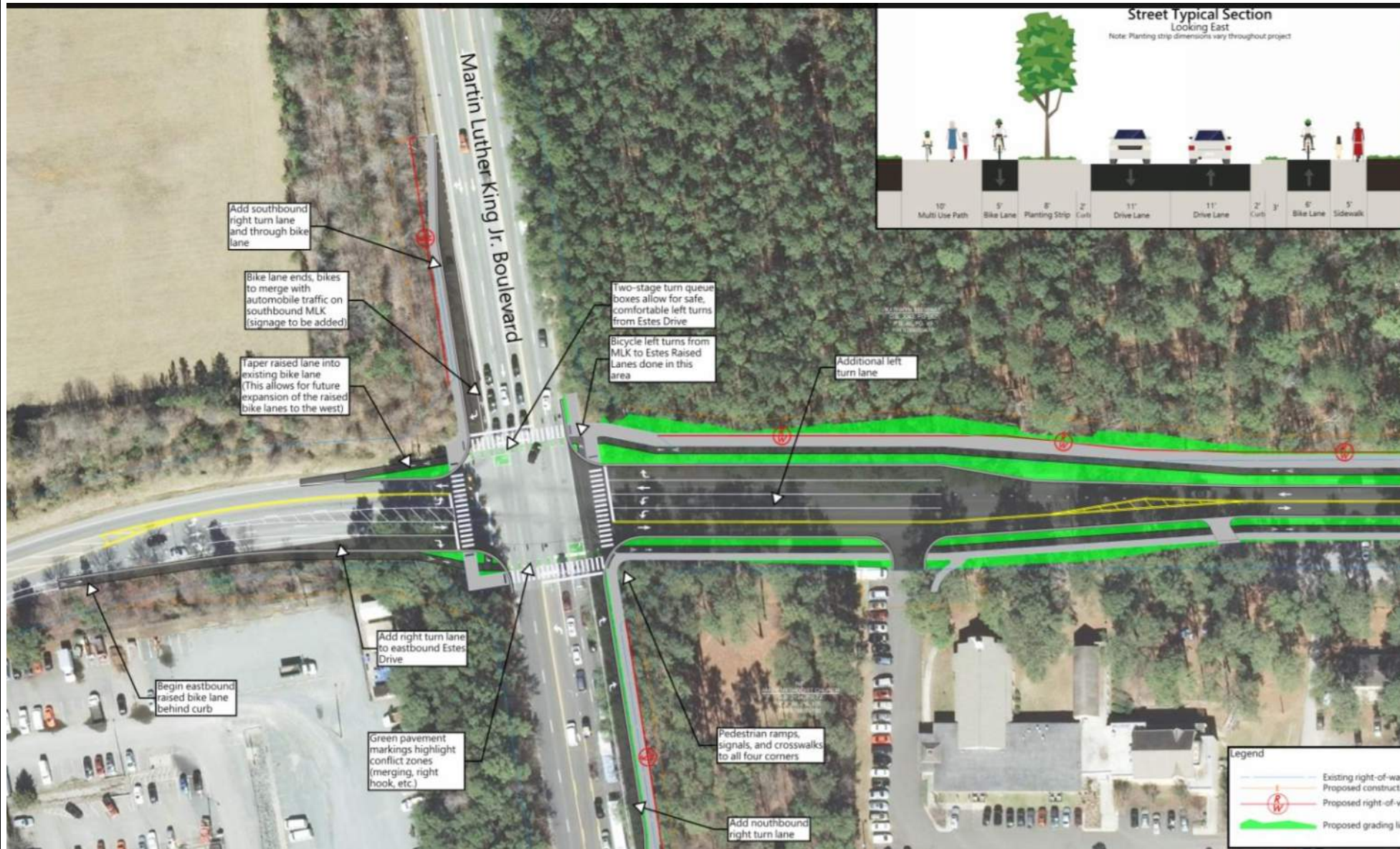

HNTB



NOT TO SCALE

**Chapel Hill Municipal Services Campus
Traffic Impact Study**

DATE: February 2018

**TOWN OF CHAPEL HILL – ESTES DRIVE IMPROVEMENTS
SCHEMATIC DETAIL**

FIGURE 6

LEGEND

- XXX = AM Peak Hour Volume
- <XXX> = Noon Peak Hour Volume
- (XXX) = PM Peak Hour Volume

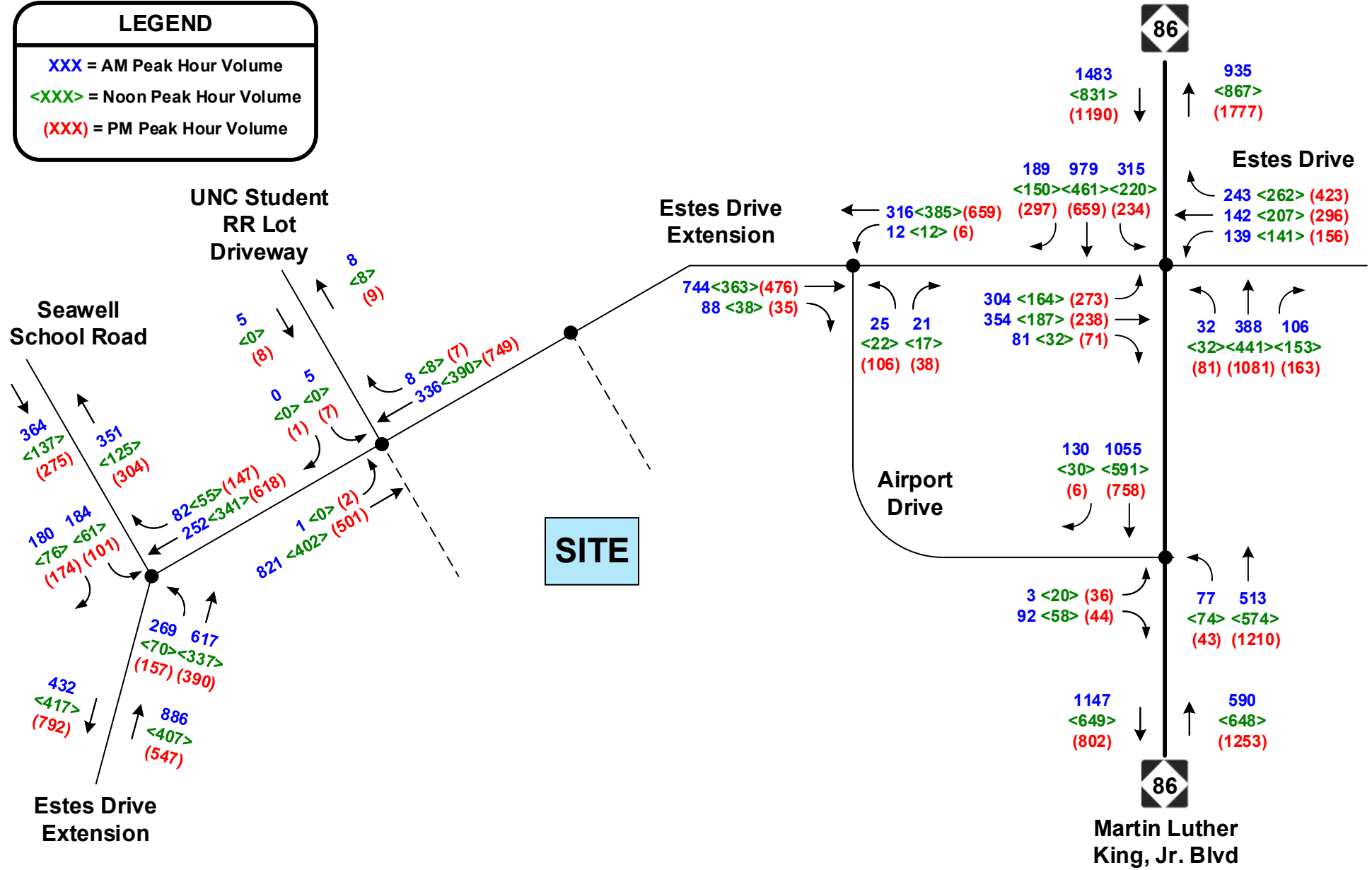

NOT TO SCALE

**Chapel Hill Municipal Services Campus
Traffic Impact Study**

DATE: February 2018

2017 EXISTING PEAK HOUR TRAFFIC VOLUMES

FIGURE 7

LEGEND

- XXX = AM Peak Hour Volume
- <XXX> = Noon Peak Hour Volume
- (XXX) = PM Peak Hour Volume

2021 Ambient Traffic Volume =
2017 Existing Traffic Volume X
1.0%/Year Growth Factor

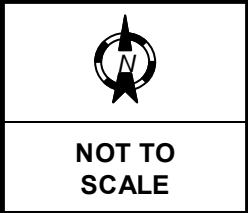
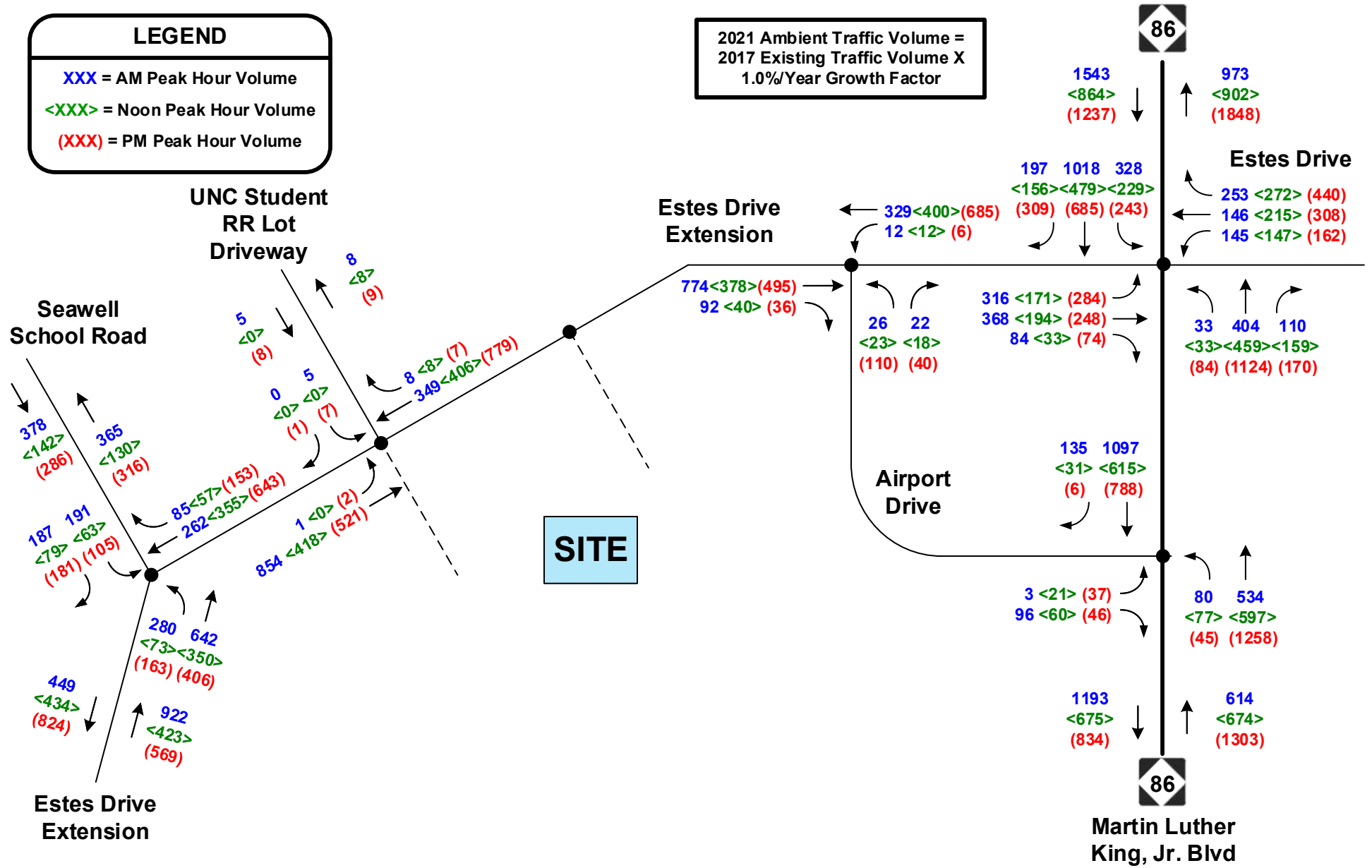

**Chapel Hill Municipal Services Campus
Traffic Impact Study**

2021 AMBIENT GROWTH PEAK HOUR TRAFFIC VOLUMES

DATE: February 2018

FIGURE 8

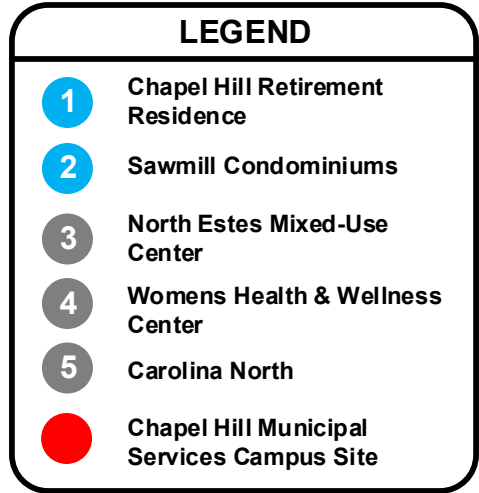
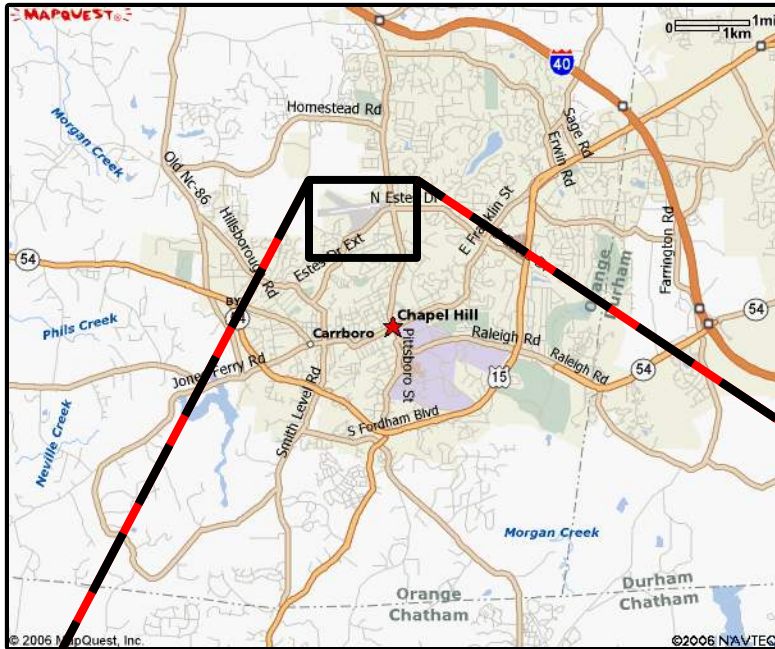

X = Not Specifically Studied as Background Generator

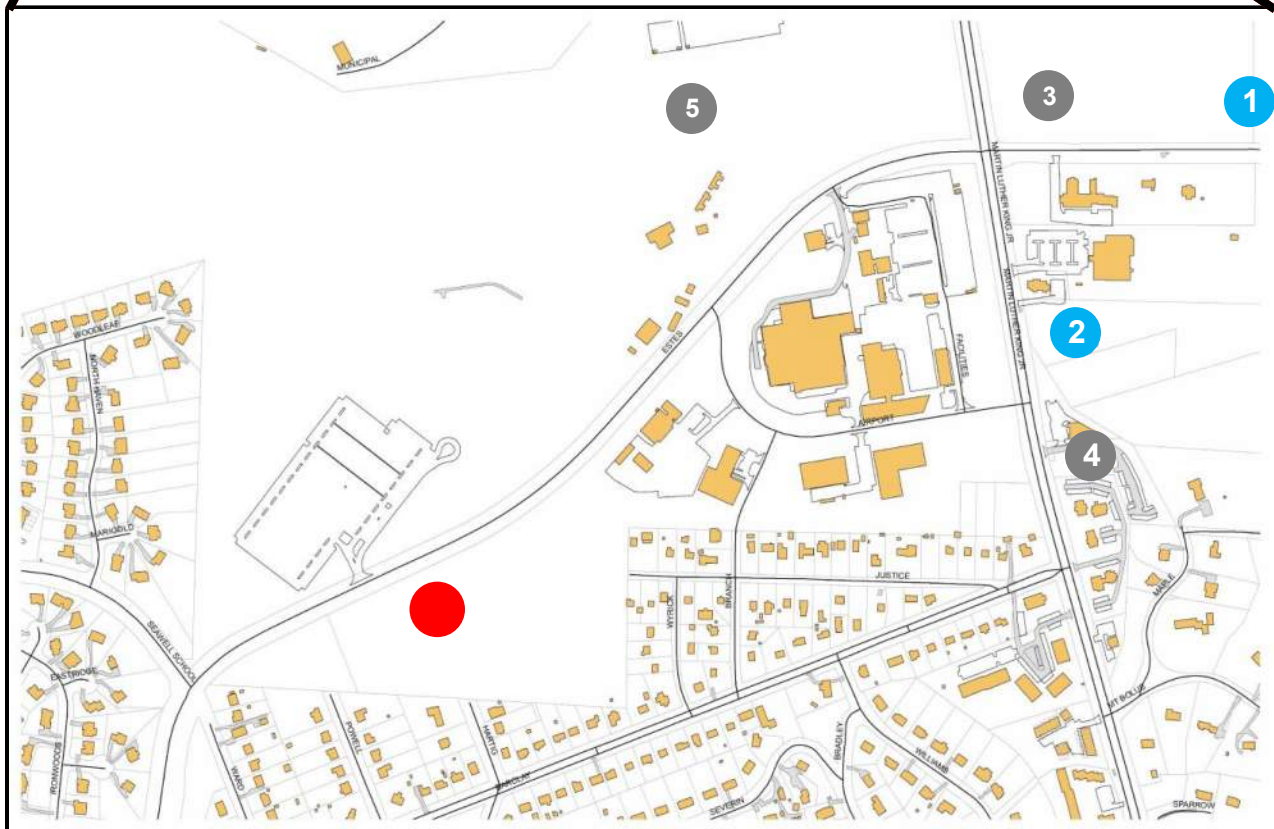

Source: Town of Chapel Hill GIS Files

NOT TO SCALE



Chapel Hill Municipal Services Campus Traffic Impact Study

DATE: February 2018

BACKGROUND DEVELOPMENT LOCATIONS

FIGURE 9

LEGEND

- XXX = AM Peak Hour Volume
- <XXX> = Noon Peak Hour Volume
- (XXX) = PM Peak Hour Volume

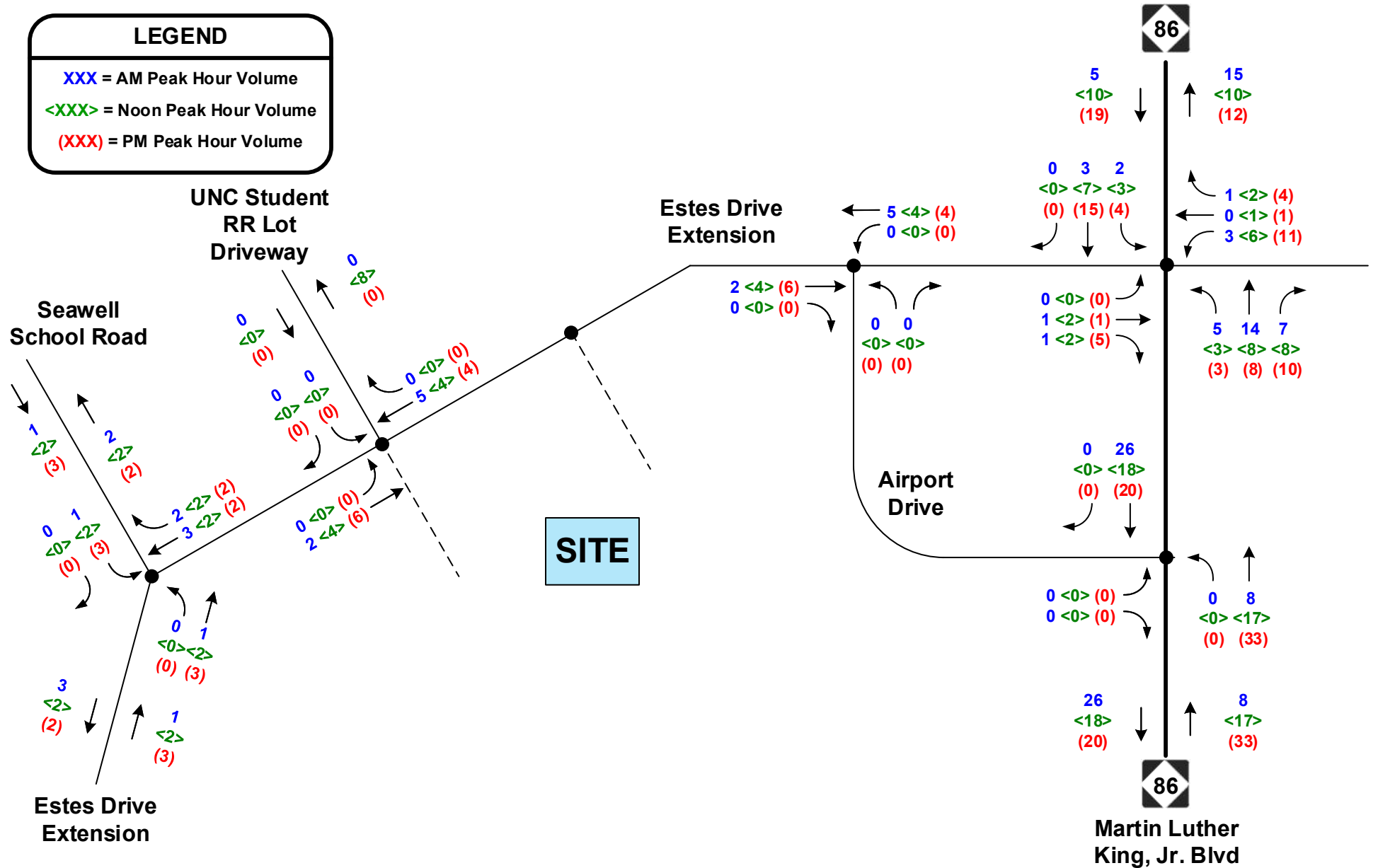

NOT TO SCALE

**Chapel Hill Municipal Services Campus
Traffic Impact Study**

**2021 TOTAL BACKGROUND GENERATOR
PEAK HOUR TRAFFIC VOLUMES**

DATE: February 2018

FIGURE 10

LEGEND

- XXX = AM Peak Hour Volume
- <XXX> = Noon Peak Hour Volume
- (XXX) = PM Peak Hour Volume

2021 Without Site Traffic Volume =
2021 Ambient Traffic Volume + 2021
Total Background Generator Volume

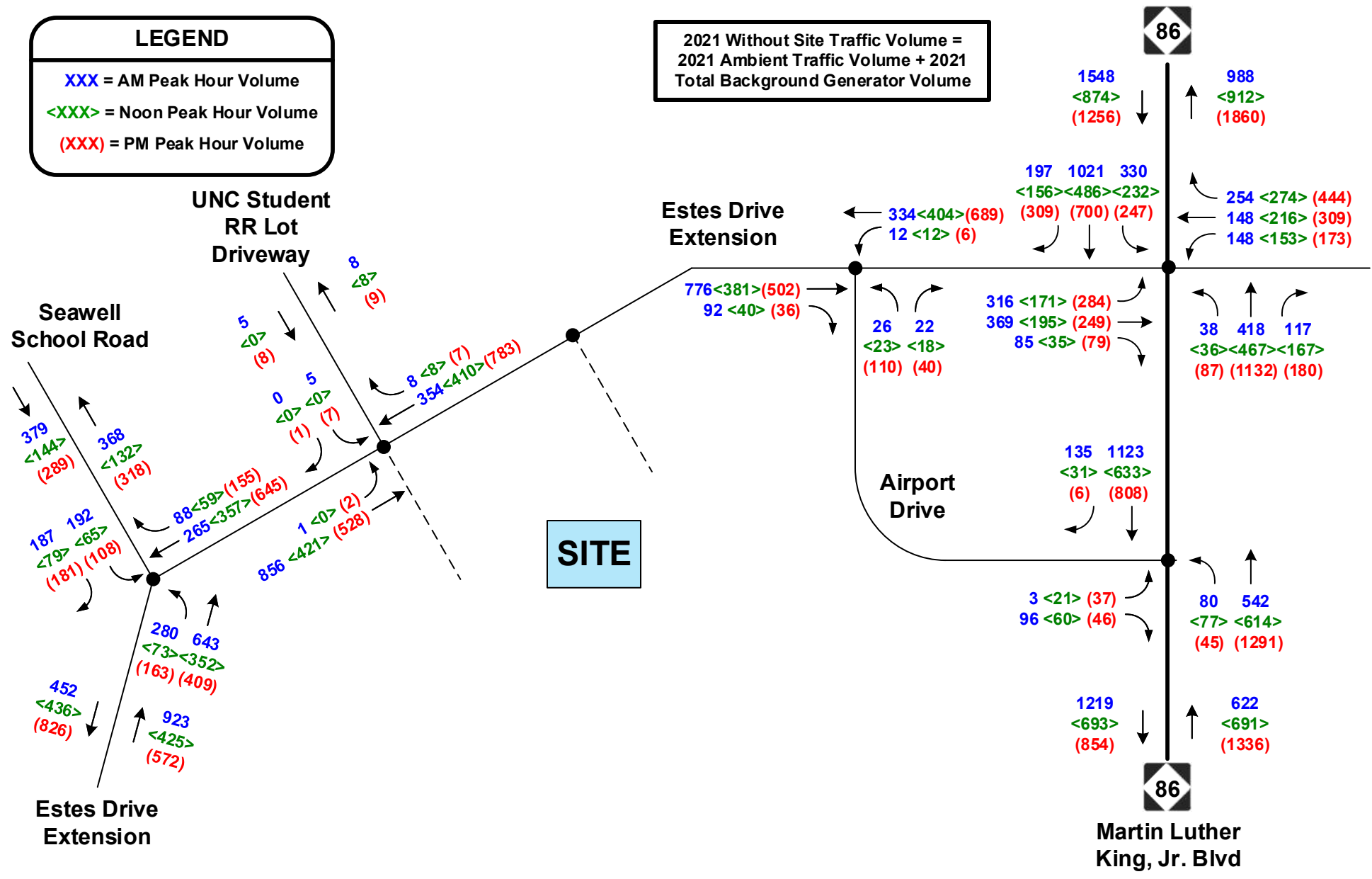

LEGEND

XX% = Site Trip Distribution Percentage Entering
 XX% = Site Trip Distribution Percentage Exiting

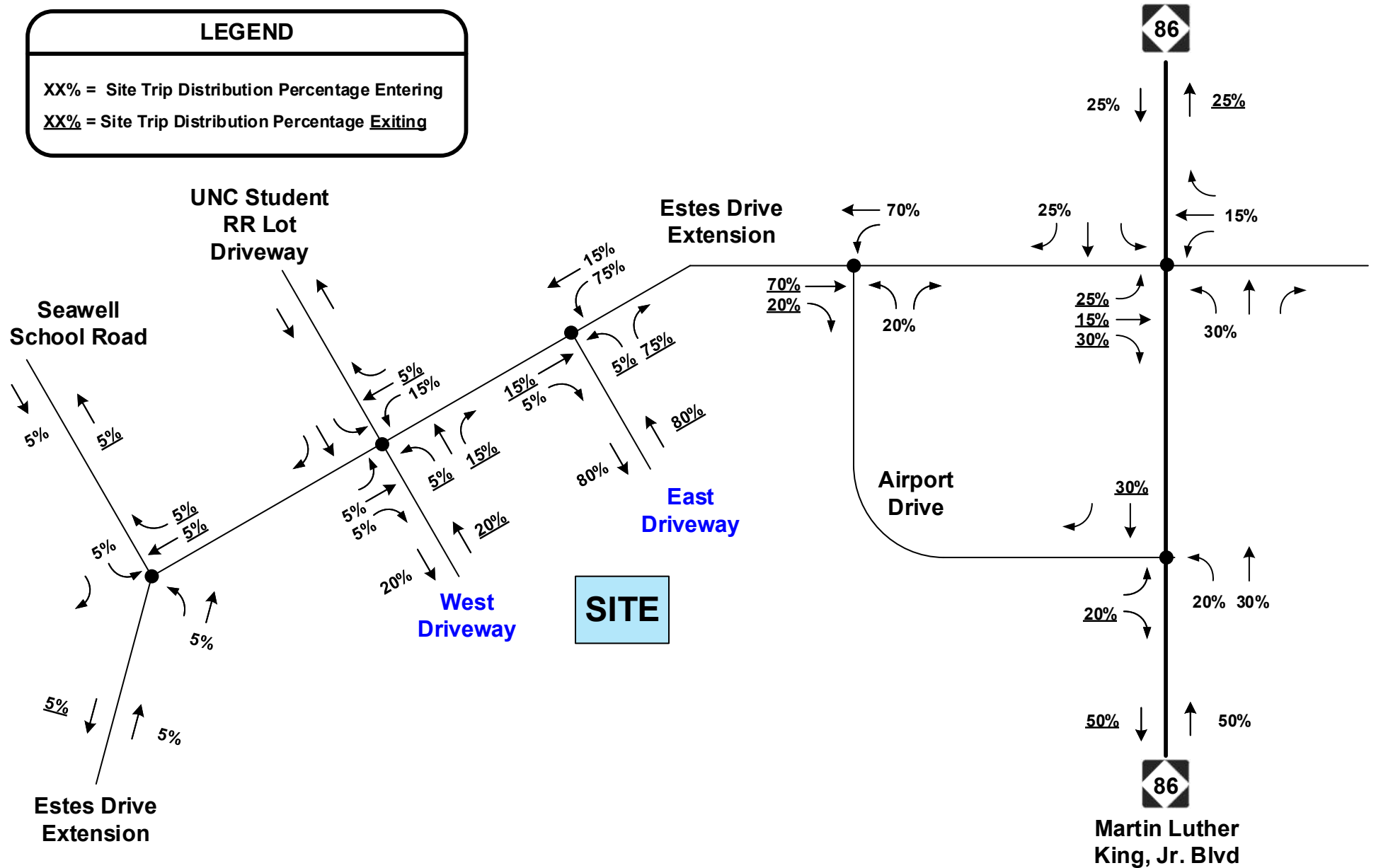

LEGEND

XX / XX = AM Peak Hour Enter / Exit
 <XX> / <XX> = Noon Peak Hour Enter / Exit
 (XX) / (XX) = PM Peak Hour Enter / Exit

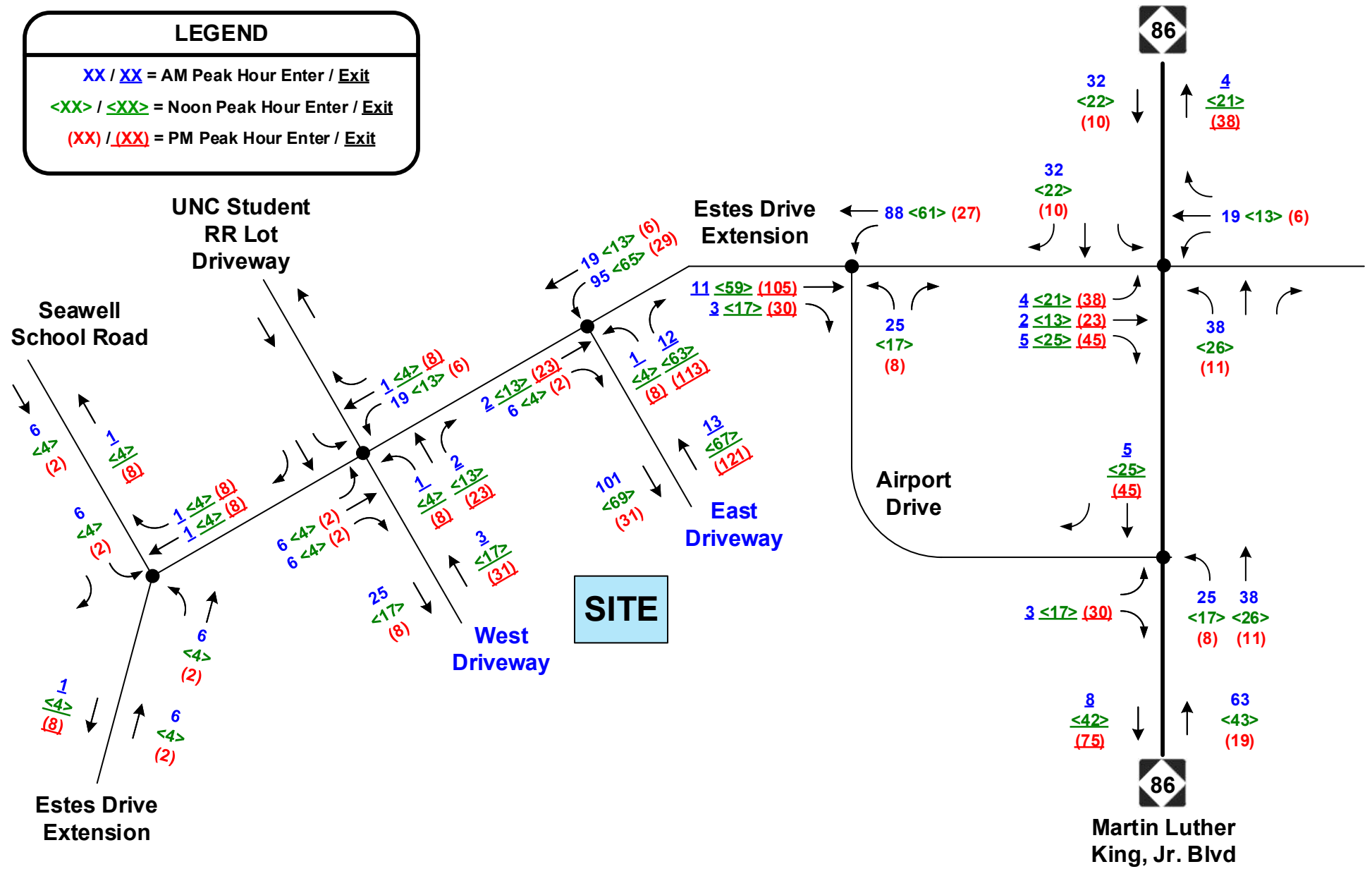

		<p>NOT TO SCALE</p>	<p>Chapel Hill Municipal Services Campus Traffic Impact Study</p>	<p>DATE: February 2018</p>
			<p>2021 PEAK HOUR SITE TRAFFIC ASSIGNMENT – PHASE 1</p>	<p>FIGURE 13</p>



LEGEND

- XXX = AM Peak Hour Volume
- <XXX> = Noon Peak Hour Volume
- (XXX) = PM Peak Hour Volume

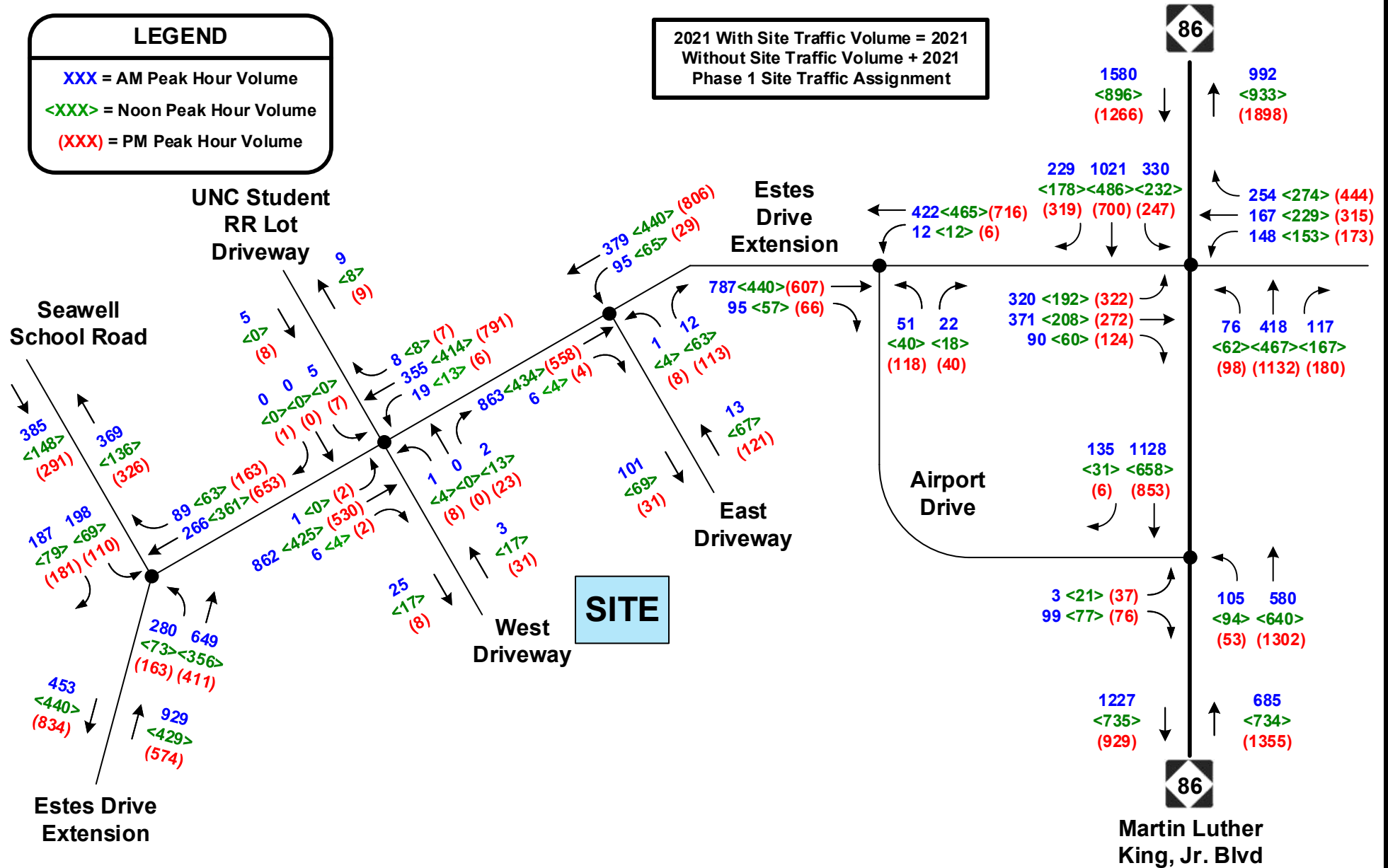
2021 With Site Traffic Volume = 2021
Without Site Traffic Volume + 2021
Phase 1 Site Traffic Assignment



LEGEND

-  = TOWN COMMITTED IMPROVEMENT
-  = NCDOT STIP IMPROVEMENT
-  = SITE PLAN ASSUMPTION

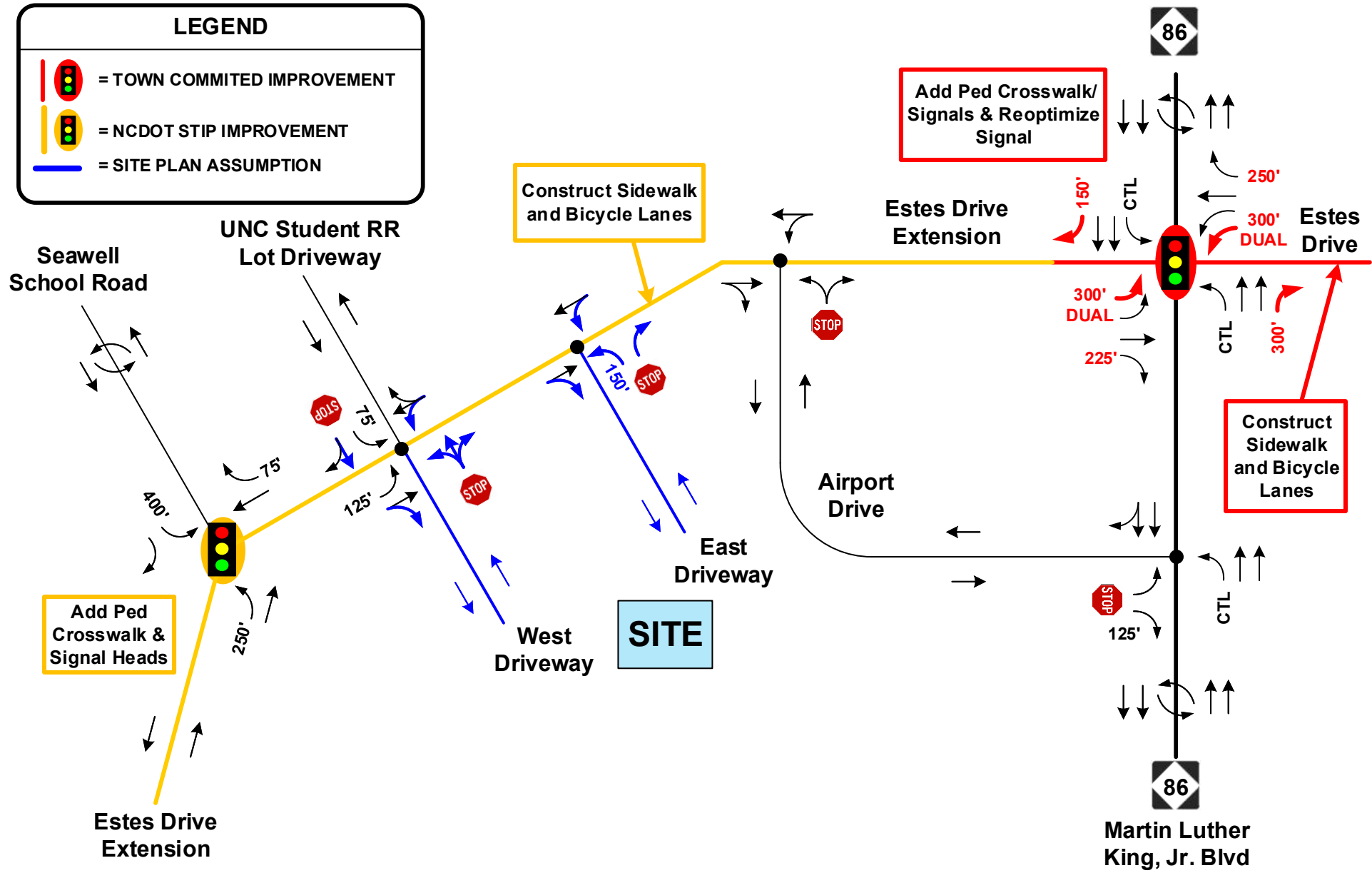

NOT TO SCALE



**Chapel Hill Municipal Services Campus
Traffic Impact Study**

2021 COMMITTED IMPROVEMENTS

DATE: February 2018

FIGURE 15

LEGEND

-  = NECESSARY IMPROVEMENT – DUE TO SITE IMPACT
-  = NECESSARY IMPROVEMENT – WITH OR WITHOUT SITE

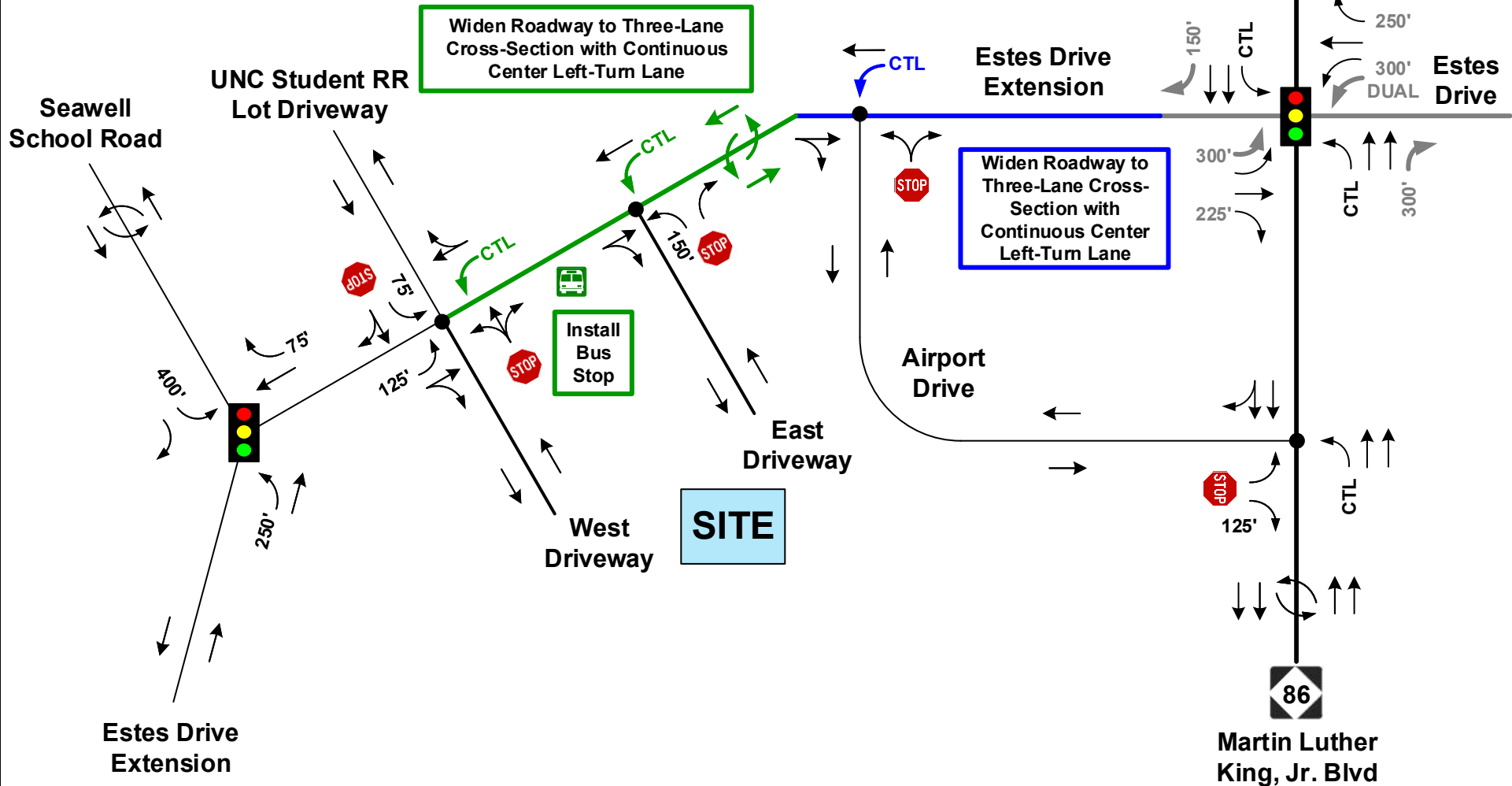

HNTB



NOT TO SCALE

**Chapel Hill Municipal Services Campus
Traffic Impact Study**

DATE: February 2018

NECESSARY IMPROVEMENTS

FIGURE 16

Appendix B – Traffic Count Data

Type of peak hour being reported: Intersection Peak

Method for determining peak hour: Total Entering Volume

LOCATION: UNC Park and Ride Dwy -- Estes Dr Ext
CITY/STATE: Chapel Hill, NC

QC JOB #: 14560301
DATE: Tue, Nov 14 2017

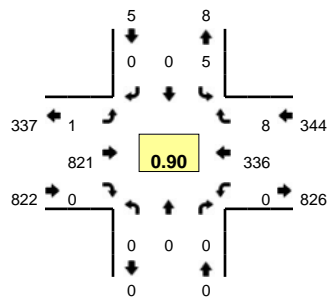

Peak-Hour: 7:40 AM -- 8:40 AM
Peak 15-Min: 7:50 AM -- 8:05 AM

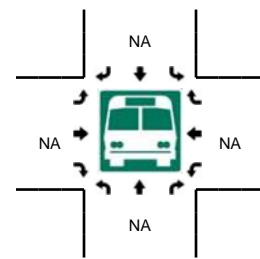
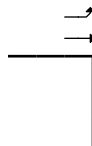
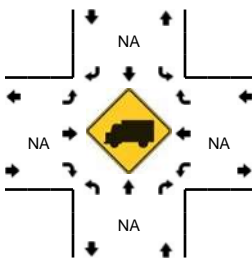
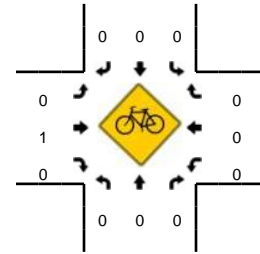
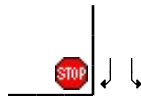
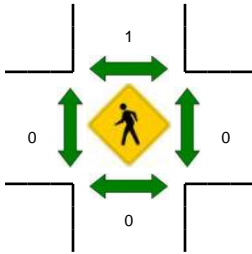
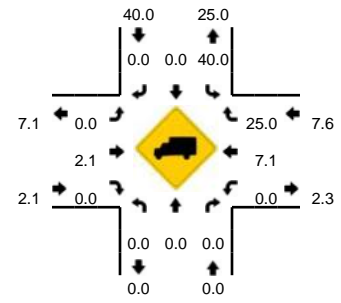

5-Min Count Period Beginning At	UNC Park and Ride Dwy (Northbound)				UNC Park and Ride Dwy (Southbound)				Estes Dr Ext (Eastbound)				Estes Dr Ext (Westbound)				Total	Hourly Totals	
	Left	Thru	Right	U	Left	Thru	Right	U	Left	Thru	Right	U	Left	Thru	Right	U			
7:00 AM	0	0	0	0	0	0	0	0	0	30	0	0	0	20	0	0	0	50	
7:05 AM	0	0	0	0	1	0	0	0	0	30	0	0	0	13	2	0	0	46	
7:10 AM	0	0	0	0	0	0	0	0	0	31	0	0	0	14	0	0	0	45	
7:15 AM	0	0	0	0	0	0	0	0	0	40	0	0	0	23	0	0	0	63	
7:20 AM	0	0	0	0	0	0	0	0	0	42	0	0	0	28	0	0	0	70	
7:25 AM	0	0	0	0	0	0	0	0	0	42	0	0	0	35	1	0	0	78	
7:30 AM	0	0	0	0	0	0	0	0	0	50	0	0	0	27	1	0	0	78	
7:35 AM	0	0	0	0	0	0	0	0	0	57	0	0	0	22	1	0	0	80	
7:40 AM	0	0	0	0	0	0	0	0	0	77	0	0	0	29	4	0	0	110	
7:45 AM	0	0	0	0	1	0	0	0	0	69	0	0	0	26	0	0	0	96	
7:50 AM	0	0	0	0	1	0	0	0	0	88	0	0	0	26	1	0	0	116	938
7:55 AM	0	0	0	0	0	0	0	0	0	84	0	0	0	22	0	0	0	106	993
8:00 AM	0	0	0	0	0	0	0	0	0	63	0	0	0	42	0	0	0	105	
8:05 AM	0	0	0	0	0	0	0	0	0	61	0	0	0	25	0	0	0	86	1033
8:10 AM	0	0	0	0	0	0	0	0	0	72	0	0	0	19	0	0	0	91	1079
8:15 AM	0	0	0	0	0	0	0	0	0	79	0	0	0	25	2	0	0	106	1122
8:20 AM	0	0	0	0	0	0	0	0	0	50	0	1	0	36	0	0	0	87	1139
8:25 AM	0	0	0	0	1	0	0	0	0	68	0	0	0	24	1	0	0	94	1155
8:30 AM	0	0	0	0	1	0	0	0	0	53	0	0	0	26	0	0	0	80	1157
8:35 AM	0	0	0	0	1	0	0	0	0	57	0	0	0	36	0	0	0	94	1171
8:40 AM	0	0	0	0	1	0	0	0	0	56	0	1	0	20	0	0	0	78	1139
8:45 AM	0	0	0	0	0	0	0	0	0	61	0	0	0	33	0	0	0	94	1137
8:50 AM	0	0	0	0	0	0	0	0	1	64	0	0	0	35	0	0	0	100	1121
8:55 AM	0	0	0	0	0	0	0	0	0	47	0	0	0	24	0	0	0	71	1086
Peak 15-Min Flowrates	Northbound				Southbound				Eastbound				Westbound				Total		
	Left	Thru	Right	U	Left	Thru	Right	U	Left	Thru	Right	U	Left	Thru	Right	U			
All Vehicles	0	0	0	0	4	0	0	0	0	940	0	0	0	360	4	0	0	1308	
Heavy Trucks	0	0	0	0	4	0	0	0	0	28	0	0	0	24	0	0	0	56	
Pedestrians	0	0	0	0	0	0	0	0	0	0	0	0	0	0	0	0	0	0	
Bicycles	0	0	0	0	0	0	0	0	0	1	0	0	0	0	0	0	0	1	
Railroad																			
Stopped Buses																			

Comments:

LOCATION: UNC Park and Ride Dwy -- Estes Dr Ext
CITY/STATE: Chapel Hill, NC

QC JOB #: 14560302
DATE: Tue, Nov 14 2017

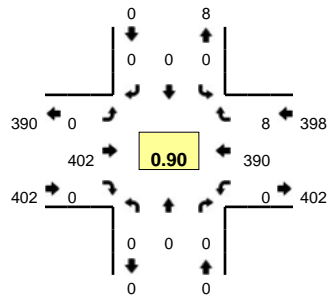

Peak-Hour: 12:05 PM -- 1:05 PM
Peak 15-Min: 12:05 PM -- 12:20 PM

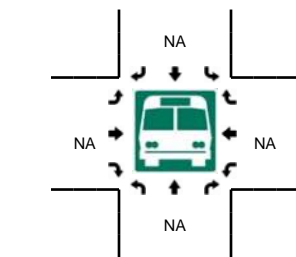
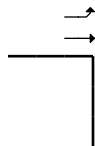
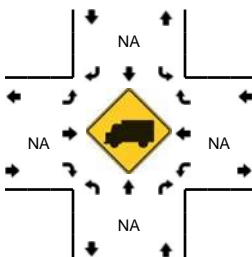
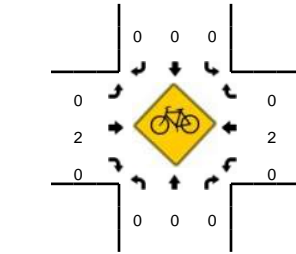
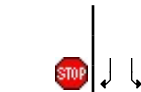
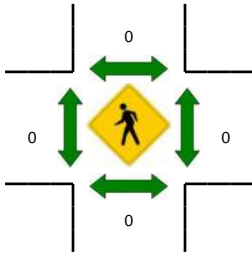
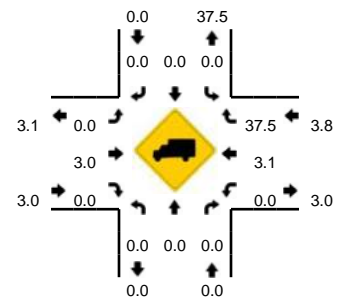

5-Min Count Period Beginning At	UNC Park and Ride Dwy (Northbound)				UNC Park and Ride Dwy (Southbound)				Estes Dr Ext (Eastbound)				Estes Dr Ext (Westbound)				Total	Hourly Totals
	Left	Thru	Right	U	Left	Thru	Right	U	Left	Thru	Right	U	Left	Thru	Right	U		
11:30 AM	0	0	0	0	0	0	0	0	0	25	0	0	0	22	0	0	47	
11:35 AM	0	0	0	0	0	0	0	0	0	25	0	0	0	25	0	0	50	
11:40 AM	0	0	0	0	0	0	0	0	0	34	0	0	0	33	0	0	67	
11:45 AM	0	0	0	0	0	0	0	0	0	29	0	0	0	31	2	0	62	
11:50 AM	0	0	0	0	0	0	0	0	0	24	0	0	0	24	0	0	48	
11:55 AM	0	0	0	0	0	0	0	0	0	26	0	0	0	29	1	0	56	
12:00 PM	0	0	0	0	0	0	0	0	0	22	0	0	0	18	0	0	40	
12:05 PM	0	0	0	0	0	0	0	0	0	40	0	0	0	38	1	0	79	
12:10 PM	0	0	0	0	0	0	0	0	0	34	0	0	0	34	0	0	68	
12:15 PM	0	0	0	0	0	0	0	0	0	42	0	0	0	32	0	0	74	
12:20 PM	0	0	0	0	0	0	0	0	0	35	0	0	0	30	0	0	65	
12:25 PM	0	0	0	0	0	0	0	0	0	34	0	0	0	42	1	0	77	733
12:30 PM	0	0	0	0	0	0	0	0	0	23	0	0	0	24	1	0	48	734
12:35 PM	0	0	0	0	0	0	0	0	0	25	0	0	0	39	1	0	65	749
12:40 PM	0	0	0	0	0	0	0	0	0	38	0	0	0	33	1	0	72	754
12:45 PM	0	0	0	0	0	0	0	0	0	30	0	0	0	32	1	0	63	755
12:50 PM	0	0	0	0	0	0	0	0	0	34	0	0	0	31	1	0	66	773
12:55 PM	0	0	0	0	0	0	0	0	0	31	0	0	0	26	0	0	57	774
1:00 PM	0	0	0	0	0	0	0	0	0	36	0	0	0	29	1	0	66	800
1:05 PM	0	0	0	0	0	0	0	0	0	27	0	0	0	24	0	0	51	772
1:10 PM	0	0	0	0	0	0	0	0	0	31	0	0	0	38	0	0	69	773
1:15 PM	0	0	0	0	0	0	0	0	0	31	0	0	0	32	2	0	65	764
1:20 PM	0	0	0	0	0	0	0	0	0	27	0	0	0	21	0	0	48	747
1:25 PM	0	0	0	0	0	0	0	0	0	30	0	0	0	32	0	0	62	732
Peak 15-Min Flowrates	Northbound				Southbound				Eastbound				Westbound				Total	
	Left	Thru	Right	U	Left	Thru	Right	U	Left	Thru	Right	U	Left	Thru	Right	U		
All Vehicles	0	0	0	0	0	0	0	0	0	464	0	0	0	416	4	0	884	
Heavy Trucks	0	0	0	0	0	0	0	0	0	24	0	0	0	8	4	0	36	
Pedestrians					0				0				0				0	
Bicycles	0	0	0	0	0	0	0	0	0	0	0	0	0	1	0	0	1	
Railroad																		
Stopped Buses																		

Comments:

LOCATION: UNC Park and Ride Dwy -- Estes Dr Ext
CITY/STATE: Chapel Hill, NC

QC JOB #: 14560303
DATE: Tue, Nov 14 2017

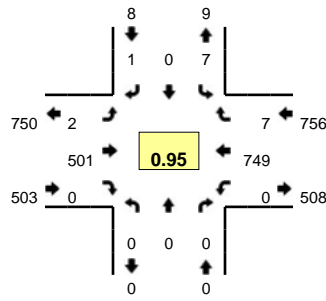

Peak-Hour: 4:35 PM -- 5:35 PM
Peak 15-Min: 5:10 PM -- 5:25 PM

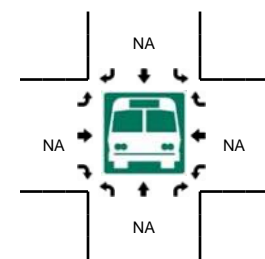
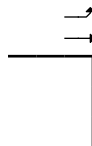
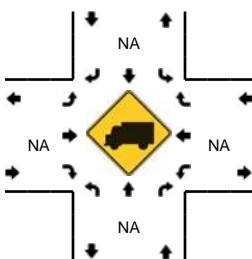
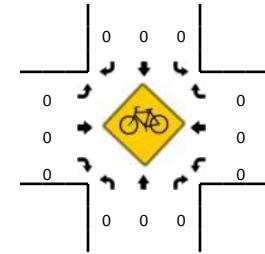
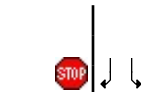
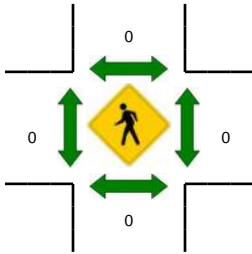
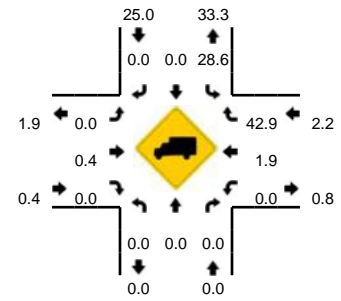

5-Min Count Period Beginning At	UNC Park and Ride Dwy (Northbound)				UNC Park and Ride Dwy (Southbound)				Estes Dr Ext (Eastbound)				Estes Dr Ext (Westbound)				Total	Hourly Totals	
	Left	Thru	Right	U	Left	Thru	Right	U	Left	Thru	Right	U	Left	Thru	Right	U			
4:00 PM	0	0	0	0	3	0	0	0	0	40	0	0	0	0	41	2	0	86	
4:05 PM	0	0	0	0	2	0	0	0	0	48	0	0	0	0	56	0	0	106	
4:10 PM	0	0	0	0	1	0	0	0	0	40	0	0	0	0	57	2	0	100	
4:15 PM	0	0	0	0	0	0	0	0	0	37	0	0	0	0	53	1	0	91	
4:20 PM	0	0	0	0	3	0	0	0	0	39	0	0	0	0	55	0	0	97	
4:25 PM	0	0	0	0	1	0	0	0	0	32	0	0	0	0	50	1	0	84	
4:30 PM	0	0	0	0	0	0	0	0	0	35	0	0	0	0	67	0	0	102	
4:35 PM	0	0	0	0	1	0	0	0	0	47	0	0	0	0	70	1	0	119	
4:40 PM	0	0	0	0	0	0	0	0	0	45	0	0	0	0	60	1	0	106	
4:45 PM	0	0	0	0	1	0	0	0	0	33	0	0	0	0	72	0	0	106	
4:50 PM	0	0	0	0	0	0	1	0	0	39	0	0	0	0	61	1	0	102	
4:55 PM	0	0	0	0	1	0	0	0	0	37	0	0	0	0	51	1	0	90	1189
5:00 PM	0	0	0	0	0	0	0	0	0	45	0	0	0	0	51	0	0	96	1199
5:05 PM	0	0	0	0	0	0	0	0	0	43	0	0	0	0	52	1	0	96	1189
5:10 PM	0	0	0	0	3	0	0	0	1	47	0	0	0	0	60	0	0	111	1200
5:15 PM	0	0	0	0	1	0	0	0	0	54	0	0	0	0	61	0	0	116	1225
5:20 PM	0	0	0	0	0	0	0	0	0	37	0	0	0	0	68	0	0	105	1233
5:25 PM	0	0	0	0	0	0	0	0	1	36	0	0	0	0	70	1	0	108	1257
5:30 PM	0	0	0	0	0	0	0	0	0	38	0	0	0	0	73	1	0	112	1267
5:35 PM	0	0	0	0	2	0	0	0	0	35	0	0	0	0	59	1	0	97	1245
5:40 PM	0	0	0	0	2	0	0	0	0	36	0	0	0	0	69	3	0	110	1249
5:45 PM	0	0	0	0	1	0	0	0	0	41	0	0	0	0	69	1	0	112	1255
5:50 PM	0	0	0	0	1	0	0	0	0	42	0	0	0	0	55	3	0	101	1254
5:55 PM	0	0	0	0	3	0	0	0	0	34	0	0	0	0	47	0	0	84	1248
Peak 15-Min Flowrates	Northbound				Southbound				Eastbound				Westbound				Total		
	Left	Thru	Right	U	Left	Thru	Right	U	Left	Thru	Right	U	Left	Thru	Right	U			
All Vehicles	0	0	0	0	16	0	0	0	4	552	0	0	0	756	0	0	1328		
Heavy Trucks	0	0	0	0	4	0	0	0	0	0	0	0	0	16	0	0	20		
Pedestrians	0	0	0	0	0	0	0	0	0	0	0	0	0	0	0	0	0		
Bicycles	0	0	0	0	0	0	0	0	0	0	0	0	0	0	0	0	0		
Railroad	0	0	0	0	0	0	0	0	0	0	0	0	0	0	0	0	0		
Stopped Buses	0	0	0	0	0	0	0	0	0	0	0	0	0	0	0	0	0		

Comments:

LOCATION: Airport Dr -- Estes Dr Ext
CITY/STATE: Chapel Hill, NC

QC JOB #: 14560304
DATE: Tue, Nov 14 2017

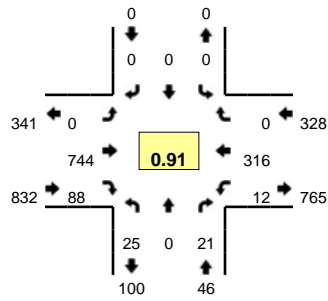

Peak-Hour: 7:40 AM -- 8:40 AM
Peak 15-Min: 7:45 AM -- 8:00 AM

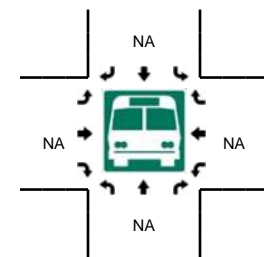
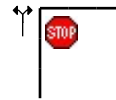
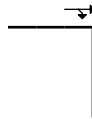
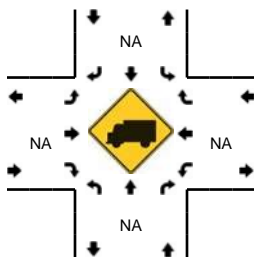
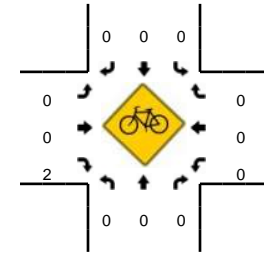
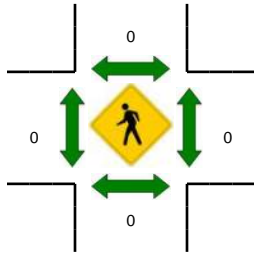
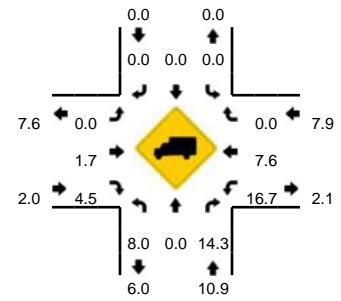

5-Min Count Period Beginning At	Airport Dr (Northbound)				Airport Dr (Southbound)				Estes Dr Ext (Eastbound)				Estes Dr Ext (Westbound)				Total	Hourly Totals
	Left	Thru	Right	U	Left	Thru	Right	U	Left	Thru	Right	U	Left	Thru	Right	U		
7:00 AM	3	0	0	0	0	0	0	0	0	28	1	0	1	17	0	0	50	
7:05 AM	1	0	1	0	0	0	0	0	0	27	3	0	0	14	0	0	46	
7:10 AM	1	0	0	0	0	0	0	0	0	29	2	0	1	14	0	0	47	
7:15 AM	3	0	1	0	0	0	0	0	0	38	3	0	0	19	0	0	64	
7:20 AM	3	0	1	0	0	0	0	0	0	37	3	0	0	32	0	0	76	
7:25 AM	1	0	2	0	0	0	0	0	0	36	5	0	0	25	0	0	69	
7:30 AM	3	0	1	0	0	0	0	0	0	46	6	0	3	29	0	0	88	
7:35 AM	3	0	1	0	0	0	0	0	0	44	8	0	3	22	0	0	81	
7:40 AM	3	0	1	0	0	0	0	0	0	69	5	0	1	31	0	0	110	
7:45 AM	2	0	2	0	0	0	0	0	0	63	11	0	0	24	0	0	102	
7:50 AM	1	0	3	0	0	0	0	0	0	77	11	0	0	25	0	0	117	
7:55 AM	2	0	1	0	0	0	0	0	0	70	11	0	1	29	0	0	114	964
8:00 AM	2	0	0	0	0	0	0	0	0	59	6	0	2	29	0	0	98	1012
8:05 AM	3	0	1	0	0	0	0	0	0	57	8	0	3	24	0	0	96	1062
8:10 AM	2	0	1	0	0	0	0	0	0	62	7	0	1	21	0	0	94	1109
8:15 AM	1	0	2	0	0	0	0	0	0	75	7	0	1	21	0	0	107	1152
8:20 AM	2	0	3	0	0	0	0	0	0	46	6	0	0	33	0	0	90	1166
8:25 AM	2	0	2	0	0	0	0	0	0	60	9	0	0	30	0	0	103	1200
8:30 AM	2	0	2	0	0	0	0	0	0	54	2	0	0	25	0	0	85	1197
8:35 AM	3	0	3	0	0	0	0	0	0	52	5	0	3	24	0	0	90	1206
8:40 AM	1	0	1	0	0	0	0	0	0	48	8	0	0	26	0	0	84	1180
8:45 AM	0	0	1	0	0	0	0	0	0	43	1	0	1	24	0	0	70	1148
8:50 AM	3	0	0	0	0	0	0	0	0	51	8	0	3	36	0	0	101	1132
8:55 AM	2	0	3	0	0	0	0	0	0	53	3	0	3	19	0	0	83	1101
Peak 15-Min Flowrates	Northbound				Southbound				Eastbound				Westbound				Total	
	Left	Thru	Right	U	Left	Thru	Right	U	Left	Thru	Right	U	Left	Thru	Right	U		
All Vehicles	20	0	24	0	0	0	0	0	0	840	132	0	4	312	0	0	1332	
Heavy Trucks	0	0	4	0	0	0	0	0	0	12	4	0	4	28	0	0	52	
Pedestrians	0	0	0	0	0	0	0	0	0	0	0	0	0	0	0	0	0	
Bicycles	0	0	0	0	0	0	0	0	0	0	0	0	0	0	0	0	0	
Railroad																		
Stopped Buses																		

Comments:

LOCATION: Airport Dr -- Estes Dr Ext
CITY/STATE: Chapel Hill, NC

QC JOB #: 14560305
DATE: Tue, Nov 14 2017

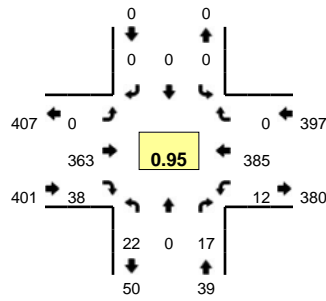

Peak-Hour: 12:05 PM -- 1:05 PM
Peak 15-Min: 12:15 PM -- 12:30 PM

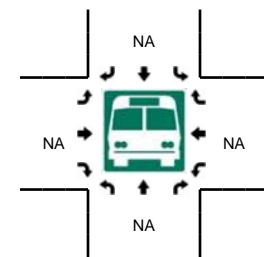
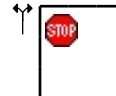
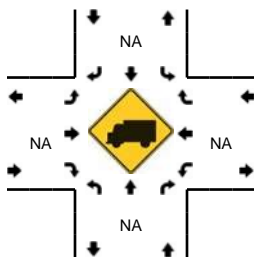
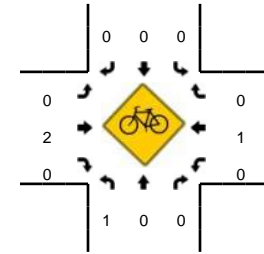
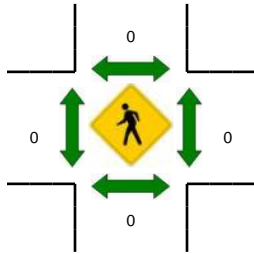
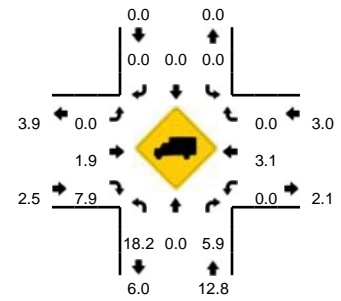

5-Min Count Period Beginning At	Airport Dr (Northbound)				Airport Dr (Southbound)				Estes Dr Ext (Eastbound)				Estes Dr Ext (Westbound)				Total	Hourly Totals
	Left	Thru	Right	U	Left	Thru	Right	U	Left	Thru	Right	U	Left	Thru	Right	U		
11:30 AM	2	0	1	0	0	0	0	0	0	21	1	0	0	28	0	0	53	
11:35 AM	3	0	1	0	0	0	0	0	0	21	3	0	1	25	0	0	54	
11:40 AM	2	0	4	0	0	0	0	0	0	28	2	0	0	23	0	0	59	
11:45 AM	5	0	2	0	0	0	0	0	0	32	4	0	1	27	0	0	71	
11:50 AM	1	0	0	0	0	0	0	0	0	29	3	0	0	24	0	0	57	
11:55 AM	0	0	5	0	0	0	0	0	0	23	2	0	0	28	0	0	58	
12:00 PM	1	0	5	0	0	0	0	0	0	27	3	0	0	21	0	0	57	
12:05 PM	7	0	1	0	0	0	0	0	0	29	2	0	1	33	0	0	73	
12:10 PM	1	0	0	0	0	0	0	0	0	31	5	0	1	30	0	0	68	
12:15 PM	3	0	0	0	0	0	0	0	0	28	2	0	2	42	0	0	77	
12:20 PM	0	0	1	0	0	0	0	0	0	31	4	0	2	32	0	0	70	
12:25 PM	1	0	2	0	0	0	0	0	0	34	1	0	1	35	0	0	74	771
12:30 PM	2	0	2	0	0	0	0	0	0	40	4	0	0	20	0	0	68	786
12:35 PM	1	0	4	0	0	0	0	0	0	33	6	0	1	32	0	0	77	809
12:40 PM	0	0	2	0	0	0	0	0	0	31	4	0	1	32	0	0	70	820
12:45 PM	1	0	2	0	0	0	0	0	0	27	3	0	0	39	0	0	72	821
12:50 PM	0	0	1	0	0	0	0	0	0	30	1	0	2	28	0	0	62	826
12:55 PM	3	0	1	0	0	0	0	0	0	25	2	0	1	30	0	0	62	830
1:00 PM	3	0	1	0	0	0	0	0	0	24	4	0	0	32	0	0	64	837
1:05 PM	0	0	1	0	0	0	0	0	0	24	1	0	1	28	0	0	55	819
1:10 PM	2	0	3	0	0	0	0	0	0	32	2	0	1	28	0	0	68	819
1:15 PM	4	0	2	0	0	0	0	0	0	34	1	0	1	31	0	0	73	815
1:20 PM	1	0	1	0	0	0	0	0	0	21	1	0	1	23	0	0	48	793
1:25 PM	2	0	2	0	0	0	0	0	0	28	3	0	0	29	0	1	65	784
Peak 15-Min Flowrates	Northbound				Southbound				Eastbound				Westbound				Total	
	Left	Thru	Right	U	Left	Thru	Right	U	Left	Thru	Right	U	Left	Thru	Right	U		
All Vehicles	16	0	12	0	0	0	0	0	0	372	28	0	20	436	0	0	884	
Heavy Trucks	0	0	4	0	0	0	0	0	0	0	4	0	0	8	0	0	16	
Pedestrians	0	0	0	0	0	0	0	0	0	0	0	0	0	0	0	0	0	
Bicycles	0	0	0	0	0	0	0	0	0	1	0	0	0	0	0	0	1	
Railroad																		
Stopped Buses																		

Comments:

LOCATION: Airport Dr -- Estes Dr Ext
CITY/STATE: Chapel Hill, NC

QC JOB #: 14560306
DATE: Tue, Nov 14 2017

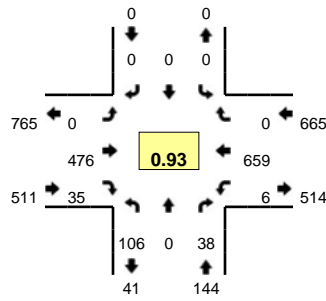

Peak-Hour: 4:35 PM -- 5:35 PM
Peak 15-Min: 4:35 PM -- 4:50 PM

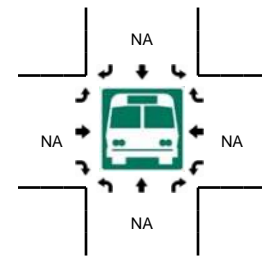
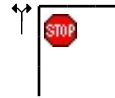
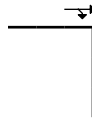
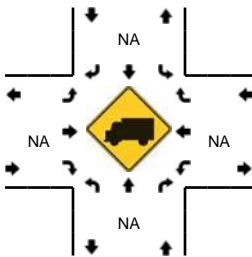
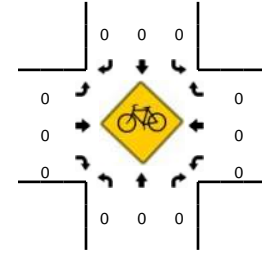
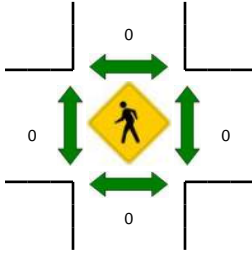
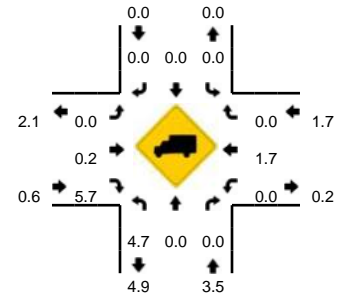

5-Min Count Period Beginning At	Airport Dr (Northbound)				Airport Dr (Southbound)				Estes Dr Ext (Eastbound)				Estes Dr Ext (Westbound)				Total	Hourly Totals
	Left	Thru	Right	U	Left	Thru	Right	U	Left	Thru	Right	U	Left	Thru	Right	U		
4:00 PM	6	0	4	0	0	0	0	0	0	34	1	0	0	41	0	0	86	
4:05 PM	8	0	4	0	0	0	0	0	0	51	5	0	1	52	0	0	121	
4:10 PM	7	0	1	0	0	0	0	0	0	43	4	0	0	48	0	0	103	
4:15 PM	5	0	4	0	0	0	0	0	0	29	1	0	0	52	0	0	91	
4:20 PM	1	0	2	0	0	0	0	0	0	46	0	0	1	58	0	0	108	
4:25 PM	1	0	3	0	0	0	0	0	0	33	1	0	0	46	0	0	84	
4:30 PM	21	0	6	0	0	0	0	0	0	35	0	0	0	48	0	0	110	
4:35 PM	18	0	7	0	0	0	0	0	0	38	4	0	1	52	0	0	120	
4:40 PM	12	0	2	0	0	0	0	0	0	47	2	0	1	62	0	0	126	
4:45 PM	8	0	2	0	0	0	0	0	0	30	7	0	0	61	0	0	108	
4:50 PM	6	0	5	0	0	0	0	0	0	34	2	0	1	50	0	0	98	
4:55 PM	7	0	2	0	0	0	0	0	0	37	3	0	0	45	0	0	94	1249
5:00 PM	5	0	2	0	0	0	0	0	0	47	2	0	0	50	0	0	106	1269
5:05 PM	9	0	6	0	0	0	0	0	0	38	3	0	1	41	0	0	98	1246
5:10 PM	9	0	3	0	0	0	0	0	0	48	1	0	0	51	0	0	112	1255
5:15 PM	11	0	4	0	0	0	0	0	0	50	7	0	0	54	0	0	126	1290
5:20 PM	8	0	3	0	0	0	0	0	0	29	3	0	2	54	0	0	99	1281
5:25 PM	8	0	1	0	0	0	0	0	0	36	1	0	0	72	0	0	118	1315
5:30 PM	5	0	1	0	0	0	0	0	0	42	0	0	0	67	0	0	115	1320
5:35 PM	3	0	4	0	0	0	0	0	0	32	3	0	0	54	0	0	96	1296
5:40 PM	7	0	2	0	0	0	0	0	0	35	3	0	0	69	0	0	116	1286
5:45 PM	6	0	1	0	0	0	0	0	0	40	0	0	0	64	0	0	111	1289
5:50 PM	2	0	0	0	0	0	0	0	0	45	1	0	0	57	0	0	105	1296
5:55 PM	0	0	3	0	0	0	0	0	0	33	6	0	0	44	0	0	86	1288
Peak 15-Min Flowrates	Northbound				Southbound				Eastbound				Westbound				Total	
All Vehicles	152	0	44	0	0	0	0	0	0	460	52	0	8	700	0	0	1416	
Heavy Trucks	4	0	0	0	0	0	0	0	0	0	0	0	0	16	0	0	20	
Pedestrians	0	0	0	0	0	0	0	0	0	0	0	0	0	0	0	0	0	
Bicycles	0	0	0	0	0	0	0	0	0	0	0	0	0	0	0	0	0	
Railroad																		
Stopped Buses																		

Comments:

LOCATION: NC 86 -- Estes Dr Ext
CITY/STATE: Chapel Hill, NC

QC JOB #: 14560307
DATE: Tue, Nov 14 2017

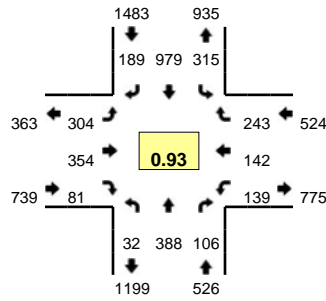

Peak-Hour: 7:30 AM -- 8:30 AM
Peak 15-Min: 7:40 AM -- 7:55 AM

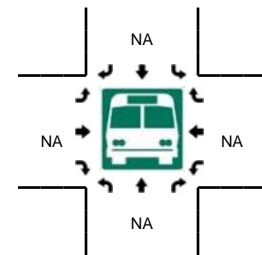
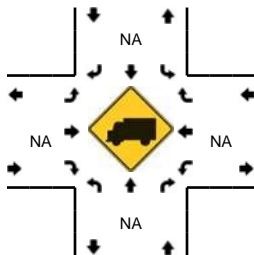
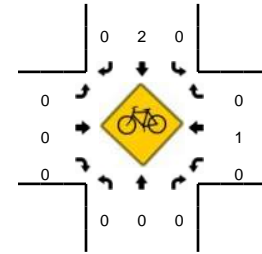
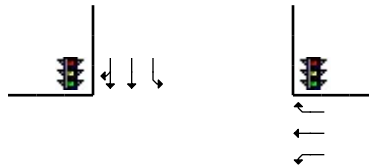
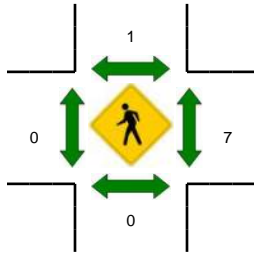
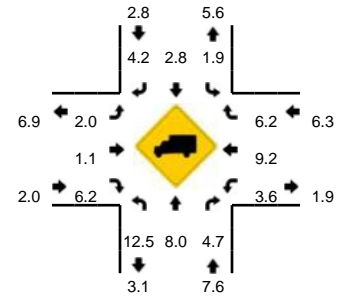

5-Min Count Period Beginning At	NC 86 (Northbound)				NC 86 (Southbound)				Estes Dr Ext (Eastbound)				Estes Dr Ext (Westbound)				Total	Hourly Totals
	Left	Thru	Right	U	Left	Thru	Right	U	Left	Thru	Right	U	Left	Thru	Right	U		
7:00 AM	0	18	2	0	9	32	12	0	10	17	3	0	6	13	3	0	125	
7:05 AM	0	31	3	0	15	65	10	0	5	12	1	0	4	3	6	0	155	
7:10 AM	1	35	2	0	14	43	10	0	10	12	1	0	3	4	7	0	142	
7:15 AM	1	23	4	0	17	61	14	0	22	19	4	0	7	13	12	0	197	
7:20 AM	0	28	7	0	27	69	20	0	15	17	1	0	9	12	6	0	211	
7:25 AM	1	23	13	0	28	83	17	0	5	12	3	0	8	8	11	0	212	
7:30 AM	0	27	4	0	24	64	19	0	21	40	5	0	15	17	25	0	261	
7:35 AM	0	33	9	0	19	85	20	0	16	21	1	0	9	12	19	0	244	
7:40 AM	2	31	11	0	33	109	28	0	30	22	3	0	9	6	18	0	302	
7:45 AM	6	36	10	0	37	107	11	0	24	31	4	0	7	9	19	0	301	
7:50 AM	2	20	7	0	31	74	17	0	22	53	8	0	12	11	21	0	278	
7:55 AM	5	47	7	0	22	75	12	0	29	35	9	0	13	11	23	0	288	2716
8:00 AM	2	15	8	0	26	54	12	0	24	26	13	0	12	15	19	0	226	2817
8:05 AM	2	30	11	0	24	96	16	0	29	21	4	0	17	14	19	0	283	2945
8:10 AM	5	47	10	0	23	84	10	0	27	20	11	0	9	6	31	0	283	3086
8:15 AM	1	36	9	0	28	76	18	0	22	26	10	0	11	9	21	0	267	3156
8:20 AM	1	25	10	0	33	91	13	0	34	31	6	0	19	20	17	0	300	3245
8:25 AM	6	41	10	0	15	64	13	0	26	28	7	0	6	12	11	0	239	3272
8:30 AM	2	24	5	0	22	97	18	0	33	25	3	0	6	10	14	0	259	3270
8:35 AM	1	18	10	0	14	76	16	0	25	24	9	0	12	11	17	0	233	3259
8:40 AM	0	33	7	0	24	72	16	0	23	25	4	0	14	12	5	0	235	3192
8:45 AM	1	23	9	0	29	97	20	0	19	18	3	0	10	14	11	0	254	3145
8:50 AM	3	20	11	0	26	76	18	0	30	29	8	0	15	16	18	0	270	3137
8:55 AM	4	28	4	0	29	59	9	0	22	35	8	0	13	14	17	0	242	3091
Peak 15-Min Flowrates	Northbound				Southbound				Eastbound				Westbound				Total	
	Left	Thru	Right	U	Left	Thru	Right	U	Left	Thru	Right	U	Left	Thru	Right	U		
All Vehicles	40	348	112	0	404	1160	224	0	304	424	60	0	112	104	232	0	3524	
Heavy Trucks	4	16	4		8	20	4		12	4	4		0	12	8		96	
Pedestrians		0				0				0				8			8	
Bicycles	0	0	0		0	0	0		0	0	0		0	0	0		0	
Railroad																		
Stopped Buses																		

Comments:

LOCATION: NC 86 -- Estes Dr Ext
CITY/STATE: Chapel Hill, NC

QC JOB #: 14560308
DATE: Tue, Nov 14 2017

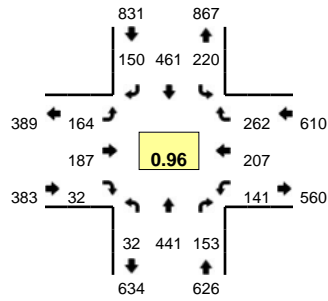

Peak-Hour: 12:15 PM -- 1:15 PM
Peak 15-Min: 12:35 PM -- 12:50 PM

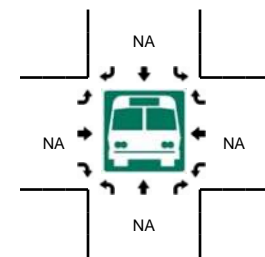
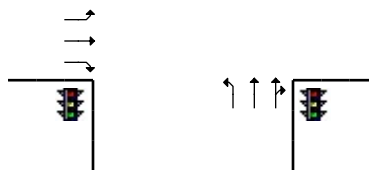
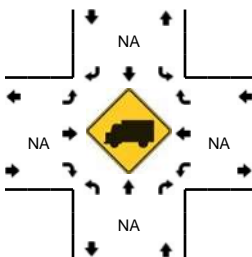
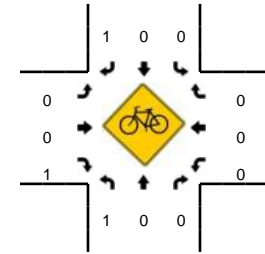
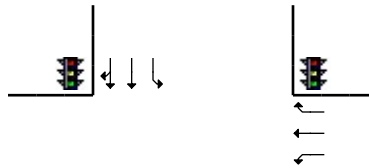
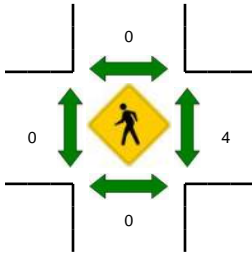
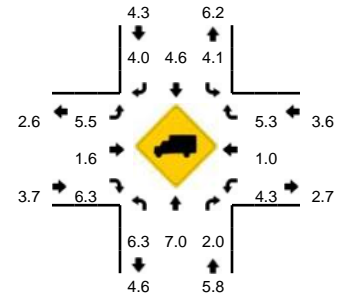

5-Min Count Period Beginning At	NC 86 (Northbound)				NC 86 (Southbound)				Estes Dr Ext (Eastbound)				Estes Dr Ext (Westbound)				Total	Hourly Totals
	Left	Thru	Right	U	Left	Thru	Right	U	Left	Thru	Right	U	Left	Thru	Right	U		
11:30 AM	1	29	9	0	14	36	8	0	11	15	2	0	12	12	13	0	162	
11:35 AM	1	37	12	0	20	34	14	0	7	11	1	0	9	12	15	0	173	
11:40 AM	3	14	9	0	20	31	4	0	21	15	3	0	7	17	12	0	156	
11:45 AM	2	39	14	0	16	42	10	0	11	15	1	0	9	13	18	0	190	
11:50 AM	1	29	5	0	14	37	11	0	12	23	2	0	13	16	17	0	180	
11:55 AM	1	44	13	0	11	31	9	0	11	14	3	0	11	13	28	0	189	
12:00 PM	1	24	13	0	18	39	9	0	18	23	4	0	10	15	16	0	190	
12:05 PM	3	61	10	0	19	42	16	0	10	14	2	0	8	16	13	0	214	
12:10 PM	2	25	6	0	16	35	8	0	16	22	5	0	14	22	19	0	190	
12:15 PM	6	40	15	0	13	43	16	0	10	10	2	0	14	17	19	0	205	
12:20 PM	5	25	10	0	26	35	11	0	20	16	2	0	14	21	22	0	207	
12:25 PM	6	51	13	0	18	48	17	0	7	17	3	0	7	14	16	0	217	2273
12:30 PM	2	32	12	0	18	32	10	0	13	22	1	0	8	16	18	0	184	2295
12:35 PM	2	52	17	0	11	49	15	0	17	22	6	0	9	8	23	0	231	2353
12:40 PM	2	27	10	0	25	28	10	0	18	16	4	0	9	29	12	0	190	2387
12:45 PM	1	52	15	0	19	47	16	0	9	10	3	0	7	16	19	0	214	2411
12:50 PM	3	22	12	0	18	38	8	0	13	22	2	0	14	21	32	0	205	2436
12:55 PM	0	39	7	0	16	43	12	0	15	9	2	0	12	16	14	0	185	2432
1:00 PM	2	27	14	0	15	29	13	0	15	14	3	0	21	18	30	0	201	2443
1:05 PM	2	38	12	0	21	37	11	0	13	10	2	0	14	11	27	0	198	2427
1:10 PM	1	36	16	0	20	32	11	0	14	19	2	0	12	20	30	0	213	2450
1:15 PM	0	49	9	0	11	29	17	0	13	16	2	0	15	14	17	0	192	2437
1:20 PM	1	33	5	0	16	29	9	0	14	16	2	0	14	17	17	0	173	2403
1:25 PM	1	33	7	0	22	55	12	0	12	10	4	0	4	13	22	0	195	2381
Peak 15-Min Flowrates	Northbound				Southbound				Eastbound				Westbound				Total	
	Left	Thru	Right	U	Left	Thru	Right	U	Left	Thru	Right	U	Left	Thru	Right	U		
All Vehicles	20	524	168	0	220	496	164	0	176	192	52	0	100	212	216	0	2540	
Heavy Trucks	4	32	0		8	20	8		12	8	8		0	8	12		120	
Pedestrians		0				0				0				8				8
Bicycles	0	0	0		0	0	0		0	0	0		0	0	0		0	
Railroad																		
Stopped Buses																		

Comments:

LOCATION: NC 86 -- Estes Dr Ext
CITY/STATE: Chapel Hill, NC

QC JOB #: 14560309
DATE: Tue, Nov 14 2017

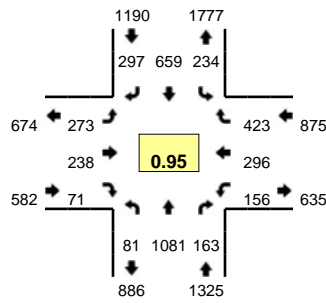

Peak-Hour: 4:55 PM -- 5:55 PM
Peak 15-Min: 5:15 PM -- 5:30 PM

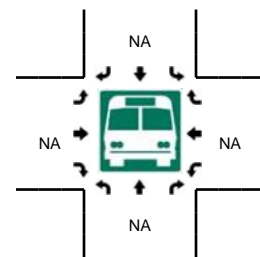
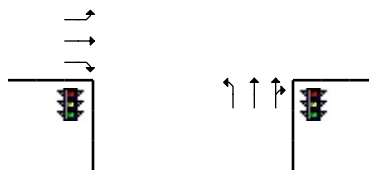
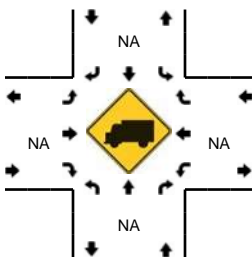
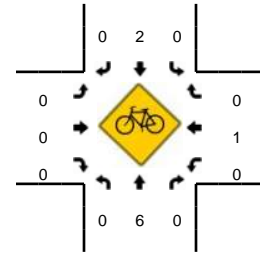
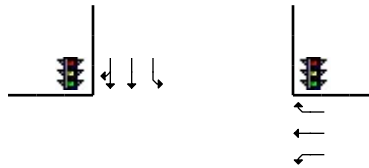
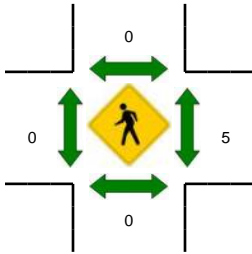
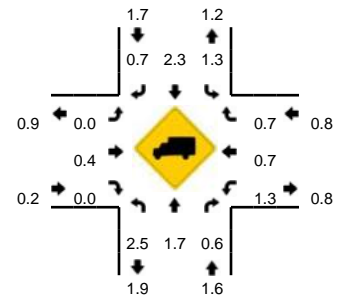

5-Min Count Period Beginning At	NC 86 (Northbound)				NC 86 (Southbound)				Estes Dr Ext (Eastbound)				Estes Dr Ext (Westbound)				Total	Hourly Totals
	Left	Thru	Right	U	Left	Thru	Right	U	Left	Thru	Right	U	Left	Thru	Right	U		
4:00 PM	4	60	17	0	24	37	18	0	20	14	5	0	13	17	22	0	251	
4:05 PM	2	76	11	0	22	51	23	0	23	21	8	0	11	19	27	0	294	
4:10 PM	8	65	13	0	17	45	22	0	25	14	3	0	11	21	31	0	275	
4:15 PM	5	74	13	0	20	39	25	0	26	18	3	0	11	21	27	0	282	
4:20 PM	4	75	19	0	26	52	28	0	16	21	5	0	14	24	47	0	331	
4:25 PM	4	57	14	0	24	42	20	0	33	17	3	0	15	20	22	0	271	
4:30 PM	4	76	13	0	20	38	18	0	25	22	5	0	16	28	38	0	303	
4:35 PM	10	97	15	0	17	50	19	0	26	20	4	0	13	20	29	0	320	
4:40 PM	15	83	17	0	19	39	18	0	22	21	8	0	13	25	30	0	310	
4:45 PM	4	79	12	0	20	63	25	0	18	18	3	0	12	26	14	0	294	
4:50 PM	8	77	17	0	26	57	17	0	23	13	2	0	19	28	22	0	309	
4:55 PM	4	67	13	0	28	41	18	0	26	26	4	0	14	22	34	0	297	3537
5:00 PM	4	80	13	0	24	45	22	0	36	22	7	0	15	19	30	0	317	3603
5:05 PM	8	86	17	0	14	45	16	0	28	27	2	0	13	27	31	0	314	3623
5:10 PM	8	96	14	0	19	42	20	0	22	26	8	0	18	25	39	0	337	3685
5:15 PM	2	120	14	0	16	68	30	0	22	25	8	0	9	22	37	0	373	3776
5:20 PM	8	101	18	0	11	48	25	0	20	15	3	0	10	21	37	0	317	3762
5:25 PM	3	107	12	0	21	66	35	0	9	16	6	0	11	27	40	0	353	3844
5:30 PM	9	91	15	0	23	53	33	0	23	8	6	0	11	26	33	0	331	3872
5:35 PM	6	92	12	0	20	49	22	0	28	14	10	0	18	23	39	0	333	3885
5:40 PM	10	84	9	0	17	69	28	0	20	20	5	0	8	33	26	0	329	3904
5:45 PM	13	83	7	0	22	54	23	0	20	20	4	0	18	31	42	0	337	3947
5:50 PM	6	74	19	0	19	79	25	0	19	19	8	0	11	20	35	0	334	3972
5:55 PM	5	57	21	0	25	58	22	0	10	17	6	0	6	17	37	0	281	3956
Peak 15-Min Flowrates	Northbound				Southbound				Eastbound				Westbound				Total	
	Left	Thru	Right	U	Left	Thru	Right	U	Left	Thru	Right	U	Left	Thru	Right	U		
All Vehicles	52	1312	176	0	192	728	360	0	204	224	68	0	120	280	456	0	4172	
Heavy Trucks	4	24	0		4	20	0		0	0	0		0	0	0		52	
Pedestrians		0				0				0				4			4	
Bicycles	0	1	0		0	1	0		0	0	0		0	0	0		2	
Railroad																		
Stopped Buses																		

Comments:

LOCATION: NC 86 -- Airport Dr
CITY/STATE: Chapel Hill, NC

QC JOB #: 14560310
DATE: Tue, Nov 14 2017

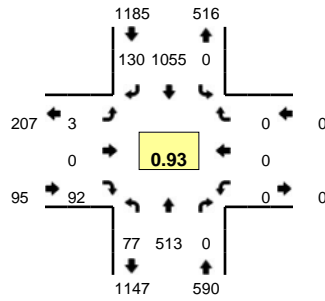

Peak-Hour: 7:35 AM -- 8:35 AM
Peak 15-Min: 7:35 AM -- 7:50 AM

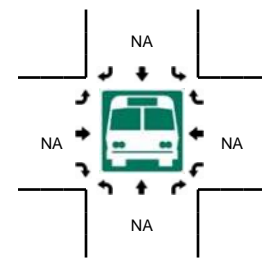
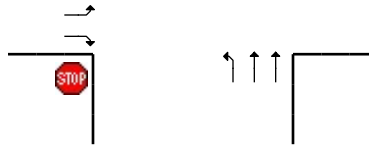
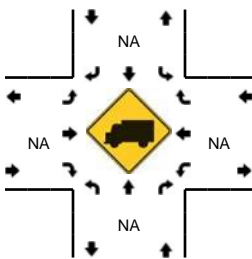
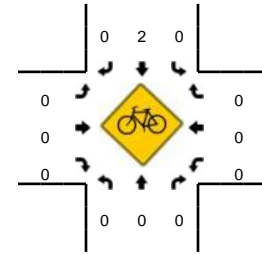
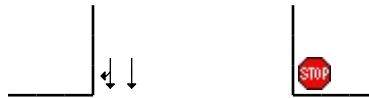
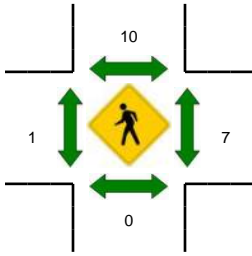
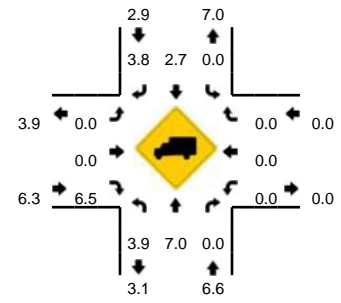

5-Min Count Period Beginning At	NC 86 (Northbound)				NC 86 (Southbound)				Airport Dr (Eastbound)				Airport Dr (Westbound)				Total	Hourly Totals
	Left	Thru	Right	U	Left	Thru	Right	U	Left	Thru	Right	U	Left	Thru	Right	U		
7:00 AM	1	20	0	0	0	37	4	0	4	0	8	0	0	0	0	0	74	
7:05 AM	3	29	0	0	0	58	9	0	2	0	2	0	0	0	0	0	103	
7:10 AM	2	36	0	0	0	49	0	0	0	0	10	0	0	0	0	0	97	
7:15 AM	4	26	0	0	0	66	6	0	1	0	5	0	0	0	0	0	108	
7:20 AM	3	29	0	0	0	59	4	0	2	0	3	0	0	0	0	0	100	
7:25 AM	1	38	0	0	0	81	13	0	0	0	3	0	0	0	0	0	136	
7:30 AM	4	31	0	0	0	77	10	0	1	0	4	0	0	0	0	0	127	
7:35 AM	12	43	0	0	0	84	8	0	0	0	6	0	0	0	0	0	153	
7:40 AM	5	43	0	0	0	90	11	0	1	0	6	0	0	0	0	0	156	
7:45 AM	8	45	0	0	0	125	10	0	0	0	4	0	0	0	0	0	192	
7:50 AM	6	40	0	0	0	82	11	0	0	0	10	0	0	0	0	0	149	
7:55 AM	7	43	0	0	0	78	17	0	0	0	8	0	0	0	0	0	153	1548
8:00 AM	6	32	0	0	0	81	8	0	0	0	8	0	0	0	0	0	135	1609
8:05 AM	9	44	0	0	0	94	19	0	1	0	3	0	0	0	0	0	170	1676
8:10 AM	5	53	0	0	0	81	9	0	0	0	6	0	0	0	0	0	154	1733
8:15 AM	6	53	0	0	0	82	12	0	0	0	12	0	0	0	0	0	165	1790
8:20 AM	5	42	0	0	0	97	11	0	0	0	14	0	0	0	0	0	169	1859
8:25 AM	2	47	0	0	0	59	9	0	1	0	10	0	0	0	0	0	128	1851
8:30 AM	6	28	0	0	0	102	5	0	0	0	5	0	0	0	0	0	146	1870
8:35 AM	4	33	0	0	0	87	6	0	0	0	4	0	0	0	0	0	134	1851
8:40 AM	3	34	0	0	0	74	5	0	0	0	12	0	0	0	0	0	128	1823
8:45 AM	2	27	0	0	0	90	3	0	1	0	7	0	0	0	0	0	130	1761
8:50 AM	5	35	0	0	0	99	8	0	0	0	11	0	0	0	0	0	158	1770
8:55 AM	2	30	0	0	0	82	3	0	0	0	10	0	0	0	0	0	127	1744
Peak 15-Min Flowrates	Northbound				Southbound				Eastbound				Westbound				Total	
	Left	Thru	Right	U	Left	Thru	Right	U	Left	Thru	Right	U	Left	Thru	Right	U		
All Vehicles	100	524	0	0	0	1196	116	0	4	0	64	0	0	0	0	0	2004	
Heavy Trucks	4	20	0	0	0	24	0	0	0	0	4	0	0	0	0	0	52	
Pedestrians		0				24					4				12		40	
Bicycles	0	0	0		0	1	0		0	0	0		0	0	0		1	
Railroad																		
Stopped Buses																		

Comments:

LOCATION: NC 86 -- Airport Dr
CITY/STATE: Chapel Hill, NC

QC JOB #: 14560311
DATE: Tue, Nov 14 2017

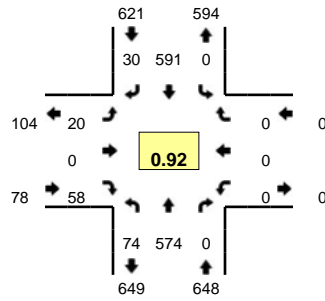

Peak-Hour: 11:45 AM -- 12:45 PM
Peak 15-Min: 12:25 PM -- 12:40 PM

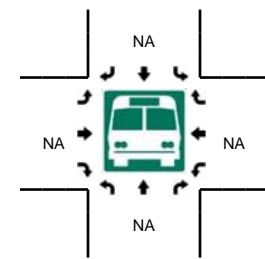
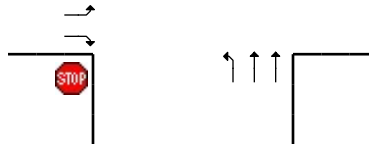
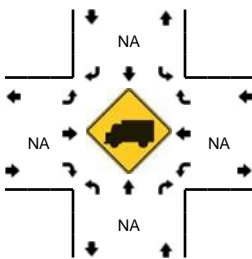
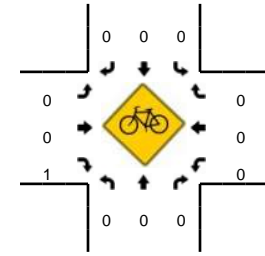
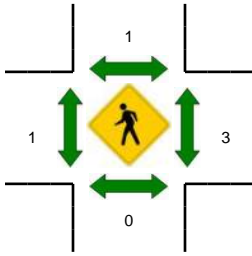
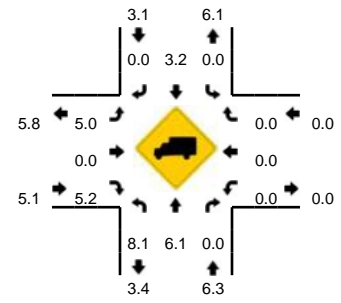

5-Min Count Period Beginning At	NC 86 (Northbound)				NC 86 (Southbound)				Airport Dr (Eastbound)				Airport Dr (Westbound)				Total	Hourly Totals
	Left	Thru	Right	U	Left	Thru	Right	U	Left	Thru	Right	U	Left	Thru	Right	U		
11:30 AM	7	40	0	0	0	55	0	0	3	0	7	0	0	0	0	0	112	
11:35 AM	7	41	0	0	0	36	0	0	0	0	4	0	0	0	0	0	88	
11:40 AM	9	24	0	0	0	41	4	0	3	0	5	0	0	0	0	0	86	
11:45 AM	9	46	0	0	0	50	4	0	3	0	8	0	0	0	0	0	120	
11:50 AM	5	36	0	0	0	52	2	0	1	0	3	0	0	0	0	0	99	
11:55 AM	8	50	0	0	0	35	2	0	2	0	3	0	0	0	0	0	100	
12:00 PM	8	41	0	0	0	54	2	0	0	0	5	0	0	0	0	0	110	
12:05 PM	8	62	0	0	0	45	0	0	1	0	5	0	0	0	0	0	121	
12:10 PM	4	39	0	0	0	57	2	0	2	0	5	0	0	0	0	0	109	
12:15 PM	8	45	0	0	0	56	3	0	4	0	4	0	0	0	0	0	120	
12:20 PM	4	48	0	0	0	52	2	0	0	0	5	0	0	0	0	0	111	
12:25 PM	2	57	0	0	0	50	2	0	3	0	6	0	0	0	0	0	120	1296
12:30 PM	9	45	0	0	0	47	2	0	0	0	3	0	0	0	0	0	106	1290
12:35 PM	6	64	0	0	0	57	6	0	2	0	6	0	0	0	0	0	141	1343
12:40 PM	3	41	0	0	0	36	3	0	2	0	5	0	0	0	0	0	90	1347
12:45 PM	3	58	0	0	0	45	5	0	0	0	5	0	0	0	0	0	116	1343
12:50 PM	5	34	0	0	0	53	3	0	0	0	3	0	0	0	0	0	98	1342
12:55 PM	8	41	0	0	0	43	3	0	1	0	7	0	0	0	0	0	103	1345
1:00 PM	2	37	0	0	0	60	0	0	1	0	4	0	0	0	0	0	104	1339
1:05 PM	0	46	0	0	0	42	7	0	0	0	6	0	0	0	0	0	101	1319
1:10 PM	5	54	0	0	0	52	1	0	0	0	14	0	0	0	0	0	126	1336
1:15 PM	14	51	0	0	0	35	0	0	0	0	2	0	0	0	0	0	102	1318
1:20 PM	4	35	0	0	0	49	1	0	0	0	10	0	0	0	0	0	99	1306
1:25 PM	7	37	0	0	0	52	1	0	1	0	12	0	0	0	0	0	110	1296
Peak 15-Min Flowrates	Northbound				Southbound				Eastbound				Westbound				Total	
	Left	Thru	Right	U	Left	Thru	Right	U	Left	Thru	Right	U	Left	Thru	Right	U		
All Vehicles	68	664	0	0	0	616	40	0	20	0	60	0	0	0	0	0	1468	
Heavy Trucks	12	24	0	0	0	12	0	0	0	0	0	0	0	0	0	0	48	
Pedestrians	0	0	0	0	0	0	0	0	0	0	0	0	12	0	0	0	12	
Bicycles	0	0	0	0	0	0	0	0	0	0	0	0	0	0	0	0	0	
Railroad																		
Stopped Buses																		

Comments:

LOCATION: NC 86 -- Airport Dr
CITY/STATE: Chapel Hill, NC

QC JOB #: 14560312
DATE: Tue, Nov 14 2017

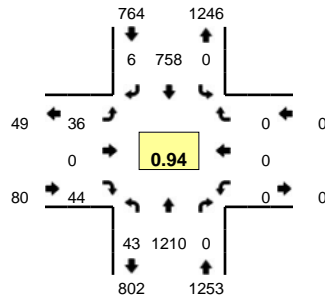

Peak-Hour: 4:45 PM -- 5:45 PM
Peak 15-Min: 5:15 PM -- 5:30 PM

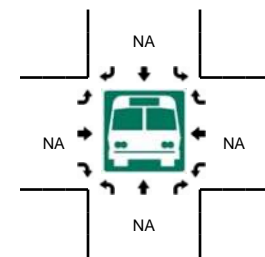
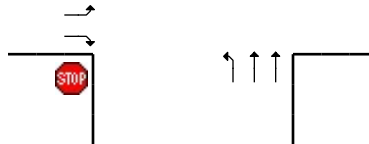
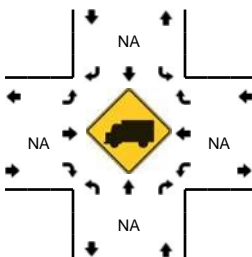
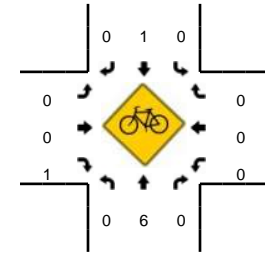
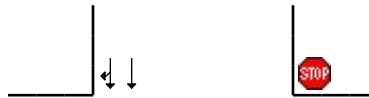
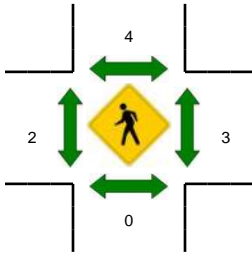
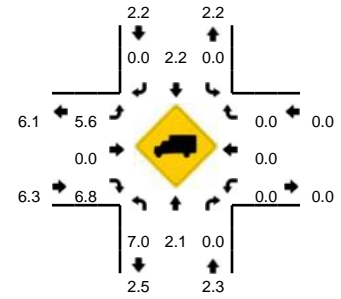

5-Min Count Period Beginning At	NC 86 (Northbound)				NC 86 (Southbound)				Airport Dr (Eastbound)				Airport Dr (Westbound)				Total	Hourly Totals
	Left	Thru	Right	U	Left	Thru	Right	U	Left	Thru	Right	U	Left	Thru	Right	U		
4:00 PM	4	68	0	0	0	52	1	0	5	0	4	0	0	0	0	0	134	
4:05 PM	4	82	0	0	0	60	1	0	9	0	9	0	0	0	0	0	165	
4:10 PM	8	80	0	1	0	57	2	0	1	0	5	0	0	0	0	0	154	
4:15 PM	8	81	0	0	0	46	2	0	4	0	5	0	0	0	0	0	146	
4:20 PM	2	89	0	0	0	67	1	0	8	0	3	0	0	0	0	0	170	
4:25 PM	4	78	0	0	0	53	2	0	3	0	3	0	0	0	0	0	143	
4:30 PM	1	83	0	0	0	48	2	0	11	0	10	0	0	0	0	0	155	
4:35 PM	4	115	0	0	0	62	1	0	10	0	9	0	0	0	0	0	201	
4:40 PM	5	80	0	0	0	44	5	0	3	0	9	0	0	0	0	0	146	
4:45 PM	4	86	0	0	0	71	2	0	5	0	4	0	0	0	0	0	172	
4:50 PM	2	77	0	0	0	72	1	0	6	0	1	0	0	0	0	0	159	
4:55 PM	3	84	0	0	0	55	0	0	3	0	2	0	0	0	0	0	147	1892
5:00 PM	3	118	0	0	0	56	0	0	4	0	6	0	0	0	0	0	187	1945
5:05 PM	4	113	0	0	0	56	0	0	6	0	8	0	0	0	0	0	187	1967
5:10 PM	4	107	0	0	0	57	0	0	1	0	3	0	0	0	0	0	172	1985
5:15 PM	4	109	0	0	0	71	0	0	0	0	6	0	0	0	0	0	190	2029
5:20 PM	6	111	0	0	0	51	1	0	1	0	4	0	0	0	0	0	174	2033
5:25 PM	6	109	0	0	0	78	0	0	1	0	2	0	0	0	0	0	196	2086
5:30 PM	2	101	0	0	0	59	0	0	3	0	0	0	0	0	0	0	165	2096
5:35 PM	3	113	0	0	0	61	1	0	3	0	3	0	0	0	0	0	184	2079
5:40 PM	2	82	0	0	0	71	1	0	3	0	5	0	0	0	0	0	164	2097
5:45 PM	2	82	0	0	0	70	1	0	2	0	1	0	0	0	0	0	158	2083
5:50 PM	2	83	0	0	0	73	0	0	1	0	1	0	0	0	0	0	160	2084
5:55 PM	0	57	0	0	0	58	1	0	2	0	4	0	0	0	0	0	122	2059
Peak 15-Min Flowrates	Northbound				Southbound				Eastbound				Westbound				Total	
	Left	Thru	Right	U	Left	Thru	Right	U	Left	Thru	Right	U	Left	Thru	Right	U		
All Vehicles	64	1316	0	0	0	800	4	0	8	0	48	0	0	0	0	0	2240	
Heavy Trucks	4	24	0	0	0	20	0	0	0	0	4	0	0	0	0	0	52	
Pedestrians	0	0	0	0	0	0	0	0	0	0	0	0	0	0	0	0	0	
Bicycles	0	1	0	0	0	0	0	0	0	0	0	0	0	0	0	0	1	
Railroad																		
Stopped Buses																		

Comments:

LOCATION: NC 86 -- Police Station Dwy North
CITY/STATE: Chapel Hill, NC

QC JOB #: 14560313
DATE: Tue, Nov 14 2017

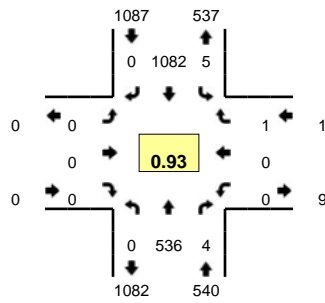

Peak-Hour: 7:25 AM -- 8:25 AM
Peak 15-Min: 7:40 AM -- 7:55 AM

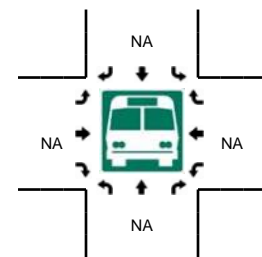
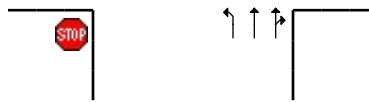
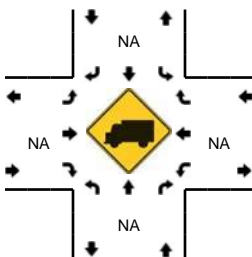
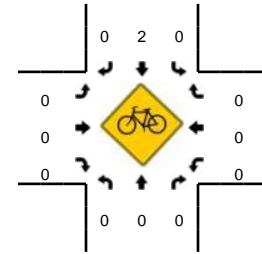
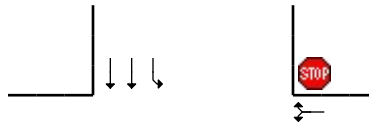
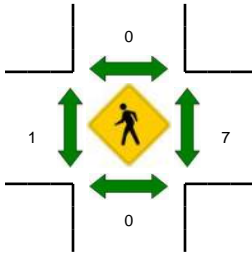
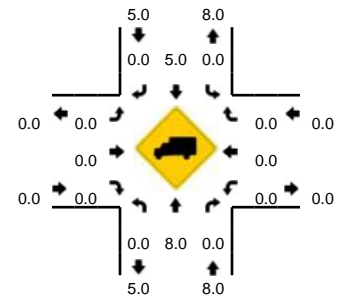

5-Min Count Period Beginning At	NC 86 (Northbound)				NC 86 (Southbound)				Police Station Dwy North (Eastbound)				Police Station Dwy North (Westbound)				Total	Hourly Totals
	Left	Thru	Right	U	Left	Thru	Right	U	Left	Thru	Right	U	Left	Thru	Right	U		
7:00 AM	0	22	0	0	1	48	0	0	0	0	0	0	0	0	0	0	71	
7:05 AM	0	35	1	0	0	48	0	0	0	0	0	0	0	0	0	0	84	
7:10 AM	0	33	0	0	0	70	0	0	0	0	0	0	0	2	0	0	105	
7:15 AM	0	33	0	0	0	68	0	0	0	0	0	0	0	0	0	0	101	
7:20 AM	0	24	1	0	0	60	0	0	0	0	0	0	0	1	0	0	86	
7:25 AM	0	33	2	0	2	79	0	0	0	0	0	0	0	0	0	0	116	
7:30 AM	0	36	0	0	0	81	0	0	0	0	0	0	0	0	0	0	117	
7:35 AM	0	50	0	0	0	102	0	0	0	0	0	0	0	0	0	0	152	
7:40 AM	0	41	0	0	0	83	0	0	0	0	0	0	0	0	1	0	125	
7:45 AM	0	55	0	0	0	106	0	0	0	0	0	0	0	0	0	0	161	
7:50 AM	0	47	0	0	0	106	0	0	0	0	0	0	0	0	0	0	153	
7:55 AM	0	38	0	0	0	79	0	0	0	0	0	0	0	0	0	0	117	1388
8:00 AM	0	34	1	0	0	77	0	0	0	0	0	0	0	0	0	0	112	1429
8:05 AM	0	64	0	0	0	100	0	0	0	0	0	0	0	0	0	0	164	1509
8:10 AM	0	37	0	0	1	84	0	0	0	0	0	0	0	0	0	0	122	1526
8:15 AM	0	49	0	0	1	75	0	0	0	0	0	0	0	0	0	0	125	1550
8:20 AM	0	52	1	0	1	110	0	0	0	0	0	0	0	0	0	0	164	1628
8:25 AM	0	40	0	0	1	71	0	0	0	0	0	0	0	0	0	0	112	1624
8:30 AM	0	31	0	0	2	79	0	0	0	0	0	0	0	1	0	0	113	1620
8:35 AM	0	39	0	0	1	102	0	0	0	0	0	0	0	1	0	0	143	1611
8:40 AM	0	22	0	0	2	80	0	0	0	0	0	0	0	0	0	0	104	1590
8:45 AM	0	28	1	0	0	84	0	0	0	0	0	0	0	0	0	0	113	1542
8:50 AM	0	39	0	0	0	108	0	0	0	0	0	0	0	0	0	0	147	1536
8:55 AM	0	36	0	0	1	97	0	0	0	0	0	0	0	0	0	0	134	1553
Peak 15-Min Flowrates	Northbound				Southbound				Eastbound				Westbound				Total	
	Left	Thru	Right	U	Left	Thru	Right	U	Left	Thru	Right	U	Left	Thru	Right	U		
All Vehicles	0	572	0	0	0	1180	0	0	0	0	0	0	0	0	4	0	1756	
Heavy Trucks	0	40	0	0	0	44	0	0	0	0	0	0	0	0	0	0	84	
Pedestrians	0	0	0	0	0	0	0	0	0	0	0	0	0	8	0	0	8	
Bicycles	0	0	0	0	0	0	0	0	0	0	0	0	0	0	0	0	0	
Railroad																		
Stopped Buses																		

Comments:

LOCATION: NC 86 -- Police Station Dwy North
CITY/STATE: Chapel Hill, NC

QC JOB #: 14560314
DATE: Tue, Nov 14 2017

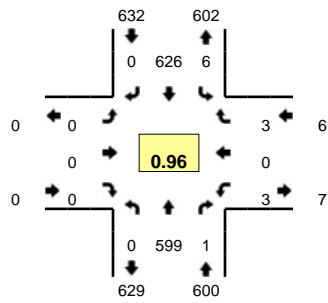

Peak-Hour: 12:05 PM -- 1:05 PM
Peak 15-Min: 12:20 PM -- 12:35 PM

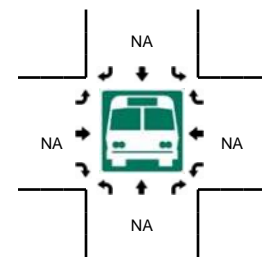
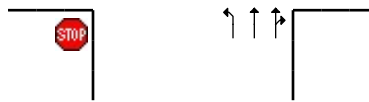
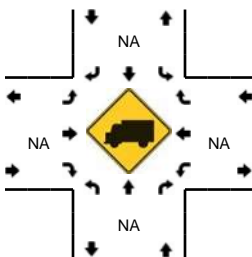
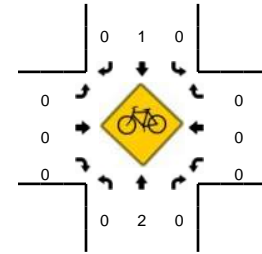
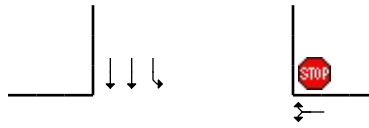
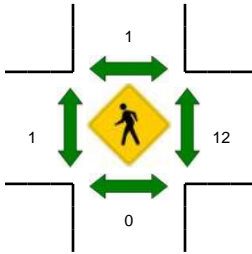
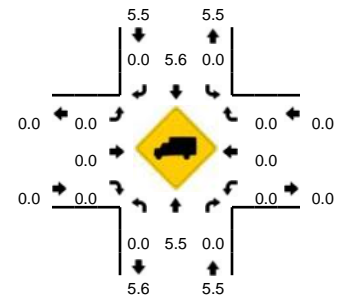

5-Min Count Period Beginning At	NC 86 (Northbound)				NC 86 (Southbound)				Police Station Dwy North (Eastbound)				Police Station Dwy North (Westbound)				Total	Hourly Totals	
	Left	Thru	Right	U	Left	Thru	Right	U	Left	Thru	Right	U	Left	Thru	Right	U			
11:30 AM	0	43	0	0	0	63	0	0	0	0	0	0	2	0	0	0	108		
11:35 AM	0	33	1	0	0	36	0	0	0	0	0	0	0	0	1	0	71		
11:40 AM	0	44	1	0	0	50	0	0	0	0	0	0	1	0	0	0	96		
11:45 AM	0	35	0	0	1	43	0	0	0	0	0	0	1	0	1	0	81		
11:50 AM	0	42	1	0	0	64	0	0	0	0	0	0	0	0	0	0	107		
11:55 AM	0	48	0	0	0	34	0	0	0	0	0	0	1	0	0	0	83		
12:00 PM	0	16	0	0	0	21	0	0	0	0	0	0	0	0	0	0	37		
12:05 PM	0	58	0	0	0	49	0	0	0	0	0	0	0	0	1	0	108		
12:10 PM	0	42	0	0	0	59	0	0	0	0	0	0	1	0	1	0	103		
12:15 PM	0	43	0	0	0	55	0	0	0	0	0	0	0	0	1	0	99		
12:20 PM	0	44	0	0	0	61	0	0	0	0	0	0	0	0	0	0	105		
12:25 PM	0	51	0	0	0	52	0	0	0	0	0	0	0	0	0	0	103	1101	
12:30 PM	0	66	0	0	0	48	0	0	0	0	0	0	0	0	0	0	114	1107	
12:35 PM	0	52	1	0	0	51	0	0	0	0	0	0	1	0	0	0	105	1141	
12:40 PM	0	51	0	0	1	47	0	0	0	0	0	0	0	0	0	0	99	1144	
12:45 PM	0	52	0	0	0	48	0	0	0	0	0	0	1	0	0	0	101	1164	
12:50 PM	0	48	0	0	1	53	0	0	0	0	0	0	0	0	0	0	102	1159	
12:55 PM	0	43	0	0	1	44	0	0	0	0	0	0	0	0	0	0	88	1164	
1:00 PM	0	49	0	0	3	59	0	0	0	0	0	0	0	0	0	0	111	1238	
1:05 PM	0	38	2	0	0	47	0	0	0	0	0	0	0	0	1	0	88	1218	
1:10 PM	0	61	0	0	0	60	0	0	0	0	0	0	0	0	1	0	122	1237	
1:15 PM	0	53	0	0	0	26	0	0	0	0	0	0	3	0	1	0	83	1221	
1:20 PM	0	44	1	0	0	63	0	0	0	0	0	0	0	0	0	0	108	1224	
1:25 PM	0	41	1	0	0	57	0	0	0	0	0	0	0	0	0	0	99	1220	
Peak 15-Min Flowrates	Northbound				Southbound				Eastbound				Westbound				Total		
	Left	Thru	Right	U	Left	Thru	Right	U	Left	Thru	Right	U	Left	Thru	Right	U			
All Vehicles	0	644	0	0	0	644	0	0	0	0	0	0	0	0	0	0	1288		
Heavy Trucks	0	44	0	0	0	28	0	0	0	0	0	0	0	0	0	0	72		
Pedestrians	0	0	0	0	0	0	0	0	0	0	0	0	16	0	0	0	16		
Bicycles	0	0	0	0	0	1	0	0	0	0	0	0	0	0	0	0	1		
Railroad																			
Stopped Buses																			

Comments:

LOCATION: NC 86 -- Police Station Dwy North
CITY/STATE: Chapel Hill, NC

QC JOB #: 14560315
DATE: Tue, Nov 14 2017

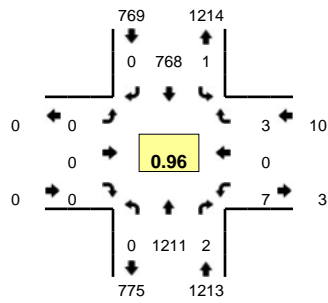

Peak-Hour: 4:45 PM -- 5:45 PM
Peak 15-Min: 5:15 PM -- 5:30 PM

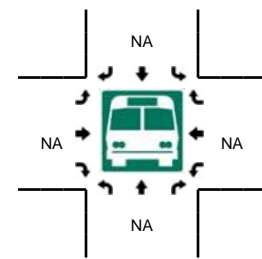
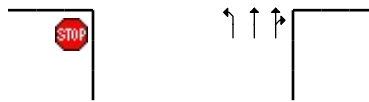
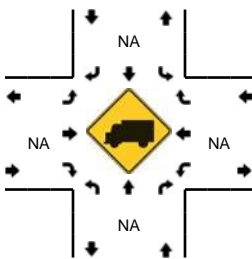
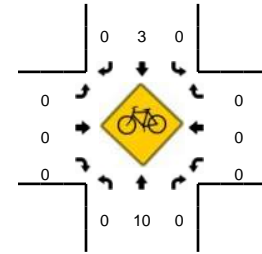
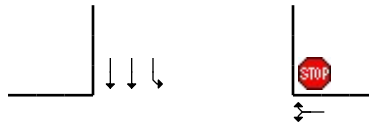
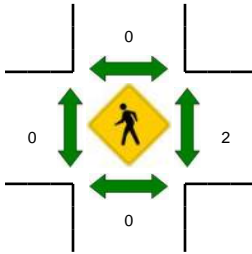
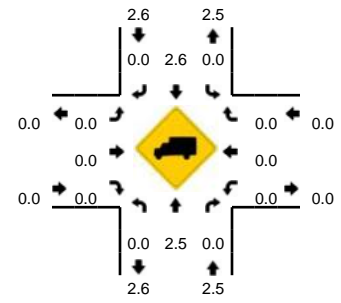

5-Min Count Period Beginning At	NC 86 (Northbound)				NC 86 (Southbound)				Police Station Dwy North (Eastbound)				Police Station Dwy North (Westbound)				Total	Hourly Totals	
	Left	Thru	Right	U	Left	Thru	Right	U	Left	Thru	Right	U	Left	Thru	Right	U			
4:00 PM	0	66	1	0	0	56	0	0	0	0	0	0	0	0	0	1	0	124	
4:05 PM	0	82	0	0	0	59	0	0	0	0	0	0	0	1	0	0	0	142	
4:10 PM	0	81	0	0	0	48	0	0	0	0	0	0	0	0	0	0	0	129	
4:15 PM	0	87	0	0	0	53	0	0	0	0	0	0	0	0	0	0	0	140	
4:20 PM	0	76	0	0	0	62	0	0	0	0	0	0	0	0	0	0	0	138	
4:25 PM	0	75	1	0	3	63	0	0	0	0	0	0	0	0	0	0	0	142	
4:30 PM	0	93	0	0	0	46	0	1	0	0	0	0	0	1	0	1	0	142	
4:35 PM	0	99	0	0	0	72	0	0	0	0	0	0	0	0	0	0	0	171	
4:40 PM	0	68	0	0	0	43	0	0	0	0	0	0	0	1	0	0	0	112	
4:45 PM	0	92	0	0	0	75	0	0	0	0	0	0	0	0	0	0	0	167	
4:50 PM	0	85	1	0	0	61	0	0	0	0	0	0	0	1	0	1	0	149	
4:55 PM	0	76	0	0	0	72	0	0	0	0	0	0	0	1	0	0	0	149	1705
5:00 PM	0	109	0	0	0	62	0	0	0	0	0	0	0	1	0	0	0	172	1753
5:05 PM	0	112	0	0	0	67	0	0	0	0	0	0	0	1	0	0	0	180	1791
5:10 PM	0	107	0	0	0	57	0	0	0	0	0	0	0	1	0	0	0	165	1827
5:15 PM	0	104	0	0	0	65	0	0	0	0	0	0	0	1	0	0	0	170	1857
5:20 PM	0	117	0	0	0	53	0	0	0	0	0	0	0	0	0	0	0	170	1889
5:25 PM	0	112	0	0	1	66	0	0	0	0	0	0	0	0	0	2	0	181	1928
5:30 PM	0	111	1	0	0	46	0	0	0	0	0	0	0	1	0	0	0	159	1945
5:35 PM	0	86	0	0	0	76	0	0	0	0	0	0	0	0	0	0	0	162	1936
5:40 PM	0	100	0	0	0	68	0	0	0	0	0	0	0	0	0	0	0	168	1992
5:45 PM	0	75	1	0	0	64	0	0	0	0	0	0	0	1	0	0	0	141	1966
5:50 PM	0	70	0	0	1	69	0	0	0	0	0	0	0	1	0	1	0	142	1959
5:55 PM	0	59	0	0	0	48	0	0	0	0	0	0	0	0	0	0	0	107	1917
Peak 15-Min Flowrates	Northbound				Southbound				Eastbound				Westbound				Total		
	Left	Thru	Right	U	Left	Thru	Right	U	Left	Thru	Right	U	Left	Thru	Right	U			
All Vehicles	0	1332	0	0	4	736	0	0	0	0	0	0	4	0	8	0	2084		
Heavy Trucks	0	36	0	0	0	16	0	0	0	0	0	0	0	0	0	0	52		
Pedestrians	0	0	0	0	0	0	0	0	0	0	0	0	4	0	0	0	4		
Bicycles	0	3	0	0	0	2	0	0	0	0	0	0	0	0	0	0	5		
Railroad																			
Stopped Buses																			

Comments:

LOCATION: NC 86 -- Police Station Dwy South
CITY/STATE: Chapel Hill, NC

QC JOB #: 14560316
DATE: Thu, Nov 16 2017

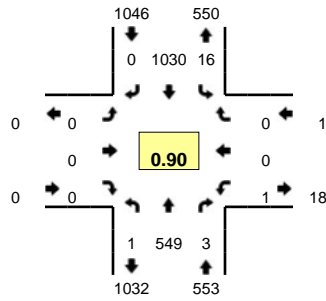

Peak-Hour: 7:45 AM -- 8:45 AM
Peak 15-Min: 7:45 AM -- 8:00 AM

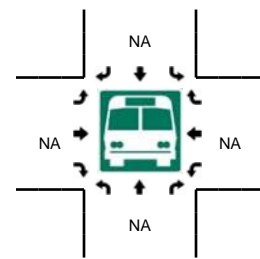
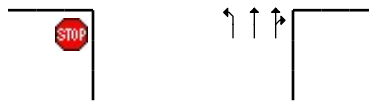
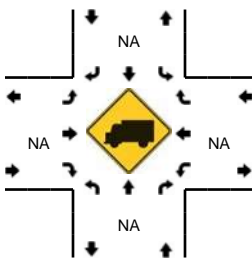
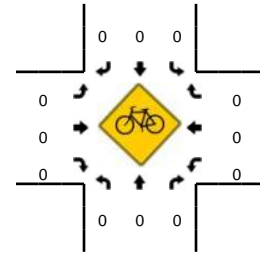
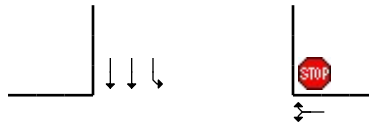
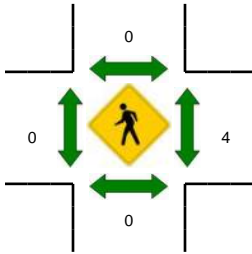
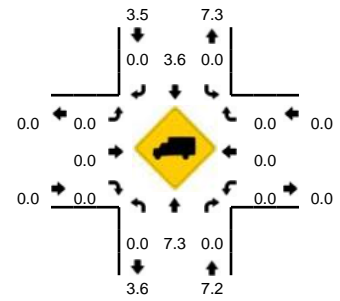

5-Min Count Period Beginning At	NC 86 (Northbound)				NC 86 (Southbound)				Police Station Dwy South (Eastbound)				Police Station Dwy South (Westbound)				Total	Hourly Totals
	Left	Thru	Right	U	Left	Thru	Right	U	Left	Thru	Right	U	Left	Thru	Right	U		
7:00 AM	0	24	0	0	0	39	0	0	0	0	0	0	0	0	0	0	63	
7:05 AM	0	44	0	0	0	41	0	0	0	0	0	0	1	0	0	0	86	
7:10 AM	0	25	1	0	1	56	0	0	0	0	0	0	0	0	0	0	83	
7:15 AM	0	29	0	0	2	65	0	0	0	0	0	0	0	0	0	0	96	
7:20 AM	0	28	1	0	0	60	0	0	0	0	0	0	0	0	0	0	89	
7:25 AM	0	29	1	0	1	66	0	0	0	0	0	0	0	0	1	0	98	
7:30 AM	0	35	0	0	1	87	0	0	0	0	0	0	0	0	0	0	123	
7:35 AM	0	45	0	0	0	70	0	0	0	0	0	0	0	0	0	0	115	
7:40 AM	0	44	0	0	0	79	0	0	0	0	0	0	1	0	0	0	124	
7:45 AM	0	64	0	0	0	126	0	0	0	0	0	0	0	0	0	0	190	
7:50 AM	0	46	0	0	1	84	0	0	0	0	0	0	0	0	0	0	131	
7:55 AM	0	41	0	0	0	80	0	0	0	0	0	0	0	0	0	0	121	1319
8:00 AM	0	57	0	1	1	70	0	0	0	0	0	0	0	0	0	0	129	1385
8:05 AM	0	59	0	0	2	93	0	0	0	0	0	0	1	0	0	0	155	1454
8:10 AM	0	49	0	0	3	65	0	0	0	0	0	0	0	0	0	0	117	1488
8:15 AM	0	32	0	0	0	73	0	0	0	0	0	0	0	0	0	0	105	1497
8:20 AM	0	52	0	0	2	102	0	0	0	0	0	0	0	0	0	0	156	1564
8:25 AM	0	43	1	0	0	84	0	1	0	0	0	0	0	0	0	0	129	1595
8:30 AM	0	33	1	0	3	65	0	0	0	0	0	0	0	0	0	0	102	1574
8:35 AM	0	38	1	0	2	87	0	0	0	0	0	0	0	0	0	0	128	1587
8:40 AM	0	35	0	0	1	101	0	0	0	0	0	0	0	0	0	0	137	1600
8:45 AM	0	38	2	0	1	93	0	0	0	0	0	0	0	0	0	0	134	1544
8:50 AM	0	46	2	0	2	94	0	0	0	0	0	0	0	0	0	0	144	1557
8:55 AM	0	35	2	0	1	67	0	0	0	0	0	0	0	0	0	0	105	1541
Peak 15-Min Flowrates	Northbound				Southbound				Eastbound				Westbound				Total	
	Left	Thru	Right	U	Left	Thru	Right	U	Left	Thru	Right	U	Left	Thru	Right	U		
All Vehicles	0	604	0	0	4	1160	0	0	0	0	0	0	0	0	0	0	1768	
Heavy Trucks	0	44	0	0	0	20	0	0	0	0	0	0	0	0	0	0	64	
Pedestrians	0	0	0	0	0	0	0	0	0	0	0	0	0	0	0	0	0	
Bicycles	0	0	0	0	0	0	0	0	0	0	0	0	0	0	0	0	0	
Railroad																		
Stopped Buses																		

Comments:

LOCATION: NC 86 -- Police Station Dwy South
CITY/STATE: Chapel Hill, NC

QC JOB #: 14560317
DATE: Thu, Nov 16 2017

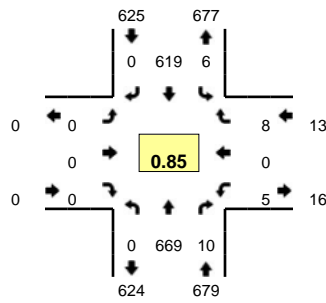

Peak-Hour: 12:30 PM -- 1:30 PM
Peak 15-Min: 1:10 PM -- 1:25 PM

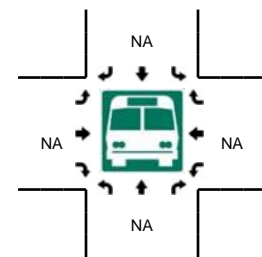
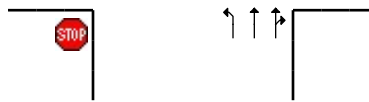
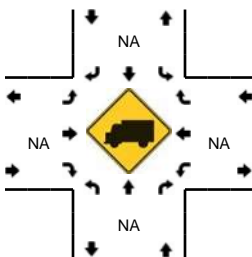
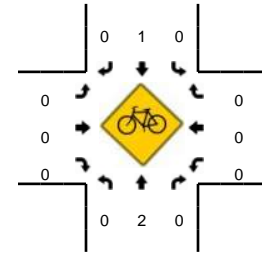
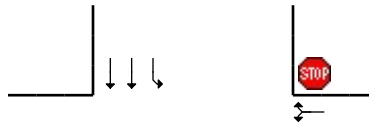
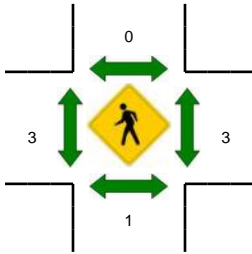
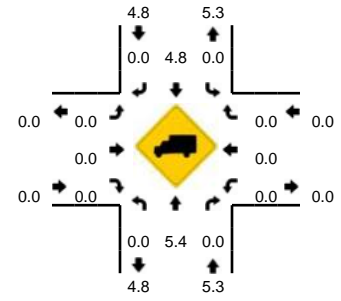

5-Min Count Period Beginning At	NC 86 (Northbound)				NC 86 (Southbound)				Police Station Dwy South (Eastbound)				Police Station Dwy South (Westbound)				Total	Hourly Totals
	Left	Thru	Right	U	Left	Thru	Right	U	Left	Thru	Right	U	Left	Thru	Right	U		
11:30 AM	0	51	0	0	1	56	0	0	0	0	0	0	1	0	0	0	109	
11:35 AM	0	32	0	0	0	35	0	0	0	0	0	0	1	0	0	0	68	
11:40 AM	0	42	1	0	0	47	0	0	0	0	0	0	0	0	0	0	90	
11:45 AM	0	46	1	0	0	48	0	0	0	0	0	0	0	0	0	0	95	
11:50 AM	0	40	1	0	0	53	0	0	0	0	0	0	0	0	0	0	94	
11:55 AM	0	39	0	0	0	68	0	0	0	0	0	0	2	0	2	0	111	
12:00 PM	0	47	1	0	1	61	0	0	0	0	0	0	1	0	1	0	112	
12:05 PM	0	50	0	0	0	47	0	0	0	0	0	0	1	0	0	0	98	
12:10 PM	0	48	0	0	0	62	0	0	0	0	0	0	5	0	0	0	115	
12:15 PM	0	48	1	0	1	59	0	0	0	0	0	0	1	0	1	0	111	
12:20 PM	0	72	1	0	1	54	0	0	0	0	0	0	0	0	1	0	129	
12:25 PM	0	50	0	0	1	35	0	0	0	0	0	0	1	0	0	0	87	1219
12:30 PM	0	64	0	0	1	47	0	0	0	0	0	0	0	0	1	0	113	1223
12:35 PM	0	49	1	0	0	60	0	0	0	0	0	0	0	0	0	0	110	1265
12:40 PM	0	59	0	0	0	55	0	0	0	0	0	0	0	0	1	0	115	1290
12:45 PM	0	39	1	0	0	47	0	0	0	0	0	0	1	0	0	0	88	1283
12:50 PM	0	49	0	0	0	56	0	0	0	0	0	0	1	0	0	0	106	1295
12:55 PM	0	48	3	0	0	40	0	0	0	0	0	0	1	0	0	0	92	1276
1:00 PM	0	57	2	0	1	48	0	0	0	0	0	0	0	0	2	0	110	1274
1:05 PM	0	54	0	0	1	48	0	0	0	0	0	0	0	0	1	0	104	1280
1:10 PM	0	56	2	0	0	72	0	0	0	0	0	0	1	0	1	0	132	1297
1:15 PM	0	68	0	0	1	50	0	0	0	0	0	0	1	0	2	0	122	1308
1:20 PM	0	75	0	0	1	56	0	0	0	0	0	0	0	0	0	0	132	1311
1:25 PM	0	51	1	0	1	40	0	0	0	0	0	0	0	0	0	0	93	1317
Peak 15-Min Flowrates	Northbound				Southbound				Eastbound				Westbound				Total	
	Left	Thru	Right	U	Left	Thru	Right	U	Left	Thru	Right	U	Left	Thru	Right	U		
All Vehicles	0	796	8	0	8	712	0	0	0	0	0	0	8	0	12	0	1544	
Heavy Trucks	0	40	0	0	0	28	0	0	0	0	0	0	0	0	0	0	68	
Pedestrians		0				0					0			4			4	
Bicycles	0	0	0		0	0	0		0	0	0		0	0	0		0	
Railroad																		
Stopped Buses																		

Comments:

LOCATION: NC 86 -- Police Station Dwy South
CITY/STATE: Chapel Hill, NC

QC JOB #: 14560318
DATE: Thu, Nov 16 2017

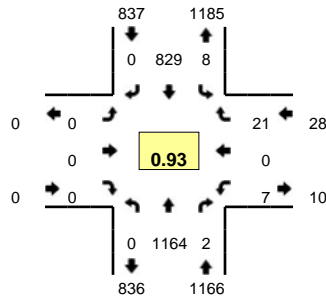

Peak-Hour: 5:00 PM -- 6:00 PM
Peak 15-Min: 5:25 PM -- 5:40 PM

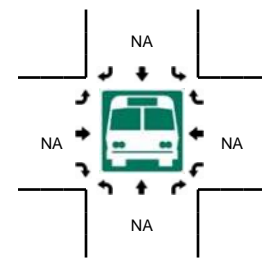
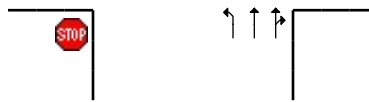
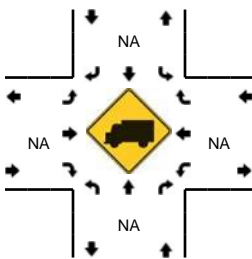
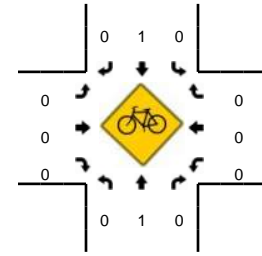
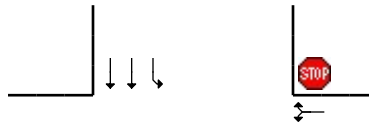
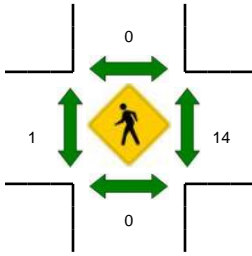
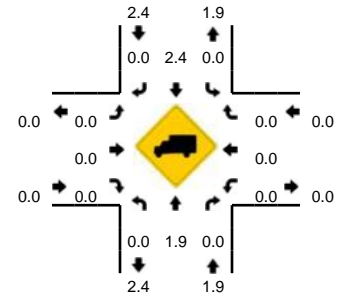

5-Min Count Period Beginning At	NC 86 (Northbound)				NC 86 (Southbound)				Police Station Dwy South (Eastbound)				Police Station Dwy South (Westbound)				Total	Hourly Totals
	Left	Thru	Right	U	Left	Thru	Right	U	Left	Thru	Right	U	Left	Thru	Right	U		
4:00 PM	0	63	0	0	0	57	0	0	0	0	0	0	0	0	0	0	120	
4:05 PM	0	62	0	0	3	57	0	0	0	0	0	0	0	0	0	0	122	
4:10 PM	0	74	0	0	1	60	0	0	0	0	0	0	0	2	0	0	137	
4:15 PM	0	70	1	0	0	65	0	0	0	0	0	0	0	0	0	0	136	
4:20 PM	0	61	2	0	1	61	0	0	0	0	0	0	2	0	2	0	129	
4:25 PM	0	61	0	0	0	62	0	0	0	0	0	0	0	0	2	0	125	
4:30 PM	0	66	1	0	0	76	0	0	0	0	0	0	0	0	0	0	143	
4:35 PM	0	78	0	0	0	68	0	0	0	0	0	0	0	0	4	0	150	
4:40 PM	0	64	0	0	1	58	0	0	0	0	0	0	0	0	0	0	123	
4:45 PM	0	106	0	0	1	48	0	0	0	0	0	0	0	0	0	0	155	
4:50 PM	0	70	0	0	2	66	0	0	0	0	0	0	0	0	1	0	139	
4:55 PM	0	86	0	0	0	63	0	0	0	0	0	0	0	0	0	0	149	1628
5:00 PM	0	86	0	0	0	66	0	0	0	0	0	0	3	0	4	0	159	1667
5:05 PM	0	112	1	0	2	82	0	0	0	0	0	0	0	0	6	0	203	1748
5:10 PM	0	81	0	0	1	71	0	0	0	0	0	0	1	0	4	0	158	1769
5:15 PM	0	93	0	0	0	69	0	0	0	0	0	0	0	0	1	0	163	1796
5:20 PM	0	121	0	0	0	53	0	0	0	0	0	0	0	0	1	0	175	1842
5:25 PM	0	109	0	0	0	74	0	0	0	0	0	0	0	0	1	0	184	1901
5:30 PM	0	106	0	0	1	71	0	0	0	0	0	0	0	0	1	0	179	1937
5:35 PM	0	103	0	0	1	80	0	0	0	0	0	0	0	0	0	0	184	1971
5:40 PM	0	102	1	0	0	76	0	0	0	0	0	0	1	0	2	0	182	2030
5:45 PM	0	78	0	0	0	60	0	0	0	0	0	0	2	0	0	0	140	2015
5:50 PM	0	94	0	0	2	55	0	0	0	0	0	0	0	0	1	0	152	2028
5:55 PM	0	79	0	0	1	72	0	0	0	0	0	0	0	0	0	0	152	2031
Peak 15-Min Flowrates	Northbound				Southbound				Eastbound				Westbound				Total	
	Left	Thru	Right	U	Left	Thru	Right	U	Left	Thru	Right	U	Left	Thru	Right	U		
All Vehicles	0	1272	0	0	8	900	0	0	0	0	0	0	0	0	8	0	2188	
Heavy Trucks	0	32	0	0	0	24	0	0	0	0	0	0	0	0	0	0	56	
Pedestrians	0	0	0	0	0	0	0	0	0	0	0	0	24	0	0	0	24	
Bicycles	0	0	0	0	0	0	0	0	0	0	0	0	0	0	0	0	0	
Railroad																		
Stopped Buses																		

Comments:

LOCATION: Seawell School Rd -- Estes Dr Ext
CITY/STATE: Chapel Hill, NC

QC JOB #: 14560319
DATE: Tue, Nov 14 2017

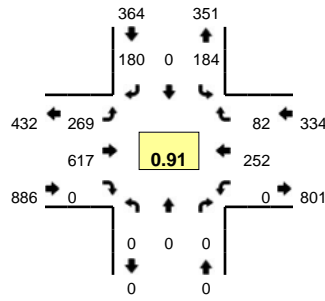

Peak-Hour: 7:40 AM -- 8:40 AM
Peak 15-Min: 7:50 AM -- 8:05 AM

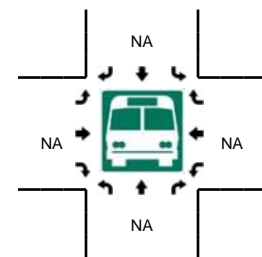
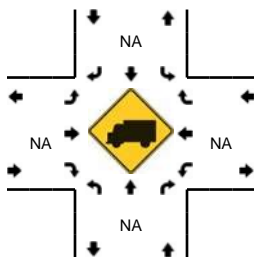
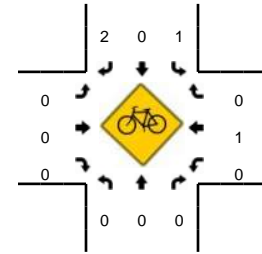
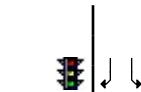
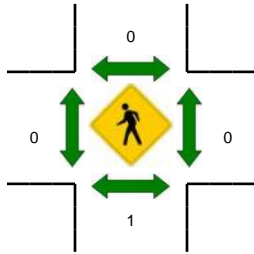
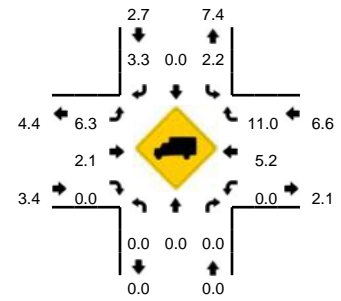

5-Min Count Period Beginning At	Seawell School Rd (Northbound)				Seawell School Rd (Southbound)				Estes Dr Ext (Eastbound)				Estes Dr Ext (Westbound)				Total	Hourly Totals
	Left	Thru	Right	U	Left	Thru	Right	U	Left	Thru	Right	U	Left	Thru	Right	U		
7:00 AM	0	0	0	0	5	0	8	0	3	24	0	0	0	13	5	0	58	
7:05 AM	0	0	0	0	6	0	3	0	3	26	0	0	0	15	0	0	53	
7:10 AM	0	0	0	0	4	0	4	0	5	27	0	0	0	11	2	0	53	
7:15 AM	0	0	0	0	10	0	1	0	3	31	0	0	0	17	5	0	67	
7:20 AM	0	0	0	0	8	0	3	0	11	30	0	0	0	21	6	0	79	
7:25 AM	0	0	0	0	11	0	11	0	9	36	0	0	0	30	6	0	103	
7:30 AM	0	0	0	0	11	0	14	0	13	40	0	0	0	19	5	0	102	
7:35 AM	0	0	0	0	6	0	14	0	12	49	0	0	0	18	6	0	105	
7:40 AM	0	0	0	0	7	0	12	0	14	65	0	0	0	28	4	0	130	
7:45 AM	0	0	0	0	18	0	11	0	19	55	0	0	0	13	11	0	127	
7:50 AM	0	0	0	0	25	0	18	0	21	66	0	0	0	23	5	0	158	
7:55 AM	0	0	0	0	19	0	24	0	16	52	0	0	0	16	4	0	131	1166
8:00 AM	0	0	0	0	14	0	15	0	23	51	0	0	0	30	13	0	146	1254
8:05 AM	0	0	0	0	14	0	8	0	24	48	0	0	0	12	8	0	114	1315
8:10 AM	0	0	0	0	22	0	19	0	17	46	0	0	0	15	7	0	126	1388
8:15 AM	0	0	0	0	19	0	10	0	14	55	0	0	0	21	2	0	121	1442
8:20 AM	0	0	0	0	15	0	15	0	26	35	0	0	0	34	4	0	129	1492
8:25 AM	0	0	0	0	12	0	13	0	30	58	0	0	0	21	6	0	140	1529
8:30 AM	0	0	0	0	7	0	18	0	37	44	0	0	0	20	8	0	134	1561
8:35 AM	0	0	0	0	12	0	17	0	28	42	0	0	0	19	10	0	128	1584
8:40 AM	0	0	0	0	12	0	12	0	12	46	0	0	0	19	5	0	106	1560
8:45 AM	0	0	0	0	12	0	14	0	12	50	0	0	0	19	7	0	114	1547
8:50 AM	0	0	0	0	15	0	12	0	11	52	0	0	0	37	5	0	132	1521
8:55 AM	0	0	0	0	5	0	11	0	6	40	0	0	0	21	4	0	87	1477
Peak 15-Min Flowrates	Northbound				Southbound				Eastbound				Westbound				Total	
	Left	Thru	Right	U	Left	Thru	Right	U	Left	Thru	Right	U	Left	Thru	Right	U		
All Vehicles	0	0	0	0	232	0	228	0	240	676	0	0	0	276	88	0	1740	
Heavy Trucks	0	0	0	0	8	0	12	0	16	24	0	0	0	8	12	0	80	
Pedestrians		4			0				0				0				4	
Bicycles	0	0	0		0	0	0		0	0	0		0	0	0		0	
Railroad																		
Stopped Buses																		

Comments:

LOCATION: Seawell School Rd -- Estes Dr Ext
CITY/STATE: Chapel Hill, NC

QC JOB #: 14560320
DATE: Tue, Nov 14 2017

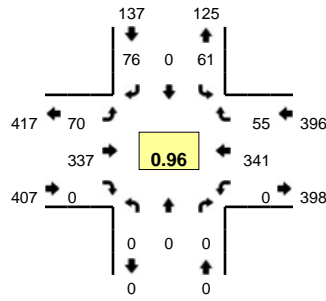

Peak-Hour: 12:05 PM -- 1:05 PM
Peak 15-Min: 12:15 PM -- 12:30 PM

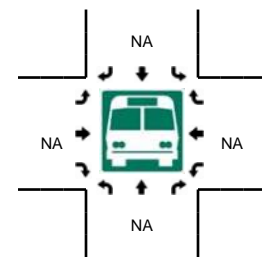
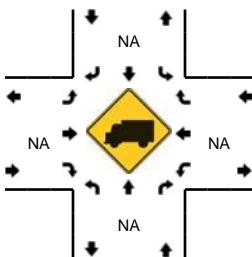
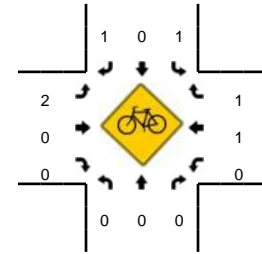
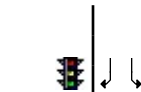
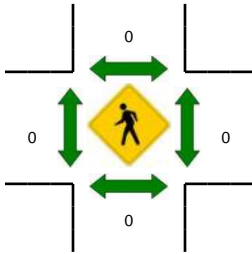
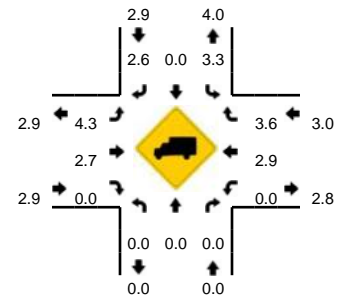

5-Min Count Period Beginning At	Seawell School Rd (Northbound)				Seawell School Rd (Southbound)				Estes Dr Ext (Eastbound)				Estes Dr Ext (Westbound)				Total	Hourly Totals
	Left	Thru	Right	U	Left	Thru	Right	U	Left	Thru	Right	U	Left	Thru	Right	U		
11:30 AM	0	0	0	0	4	0	6	0	4	16	0	0	0	24	1	0	55	
11:35 AM	0	0	0	0	3	0	5	0	4	21	0	0	0	22	3	0	58	
11:40 AM	0	0	0	0	2	0	9	0	4	30	0	0	0	26	7	0	78	
11:45 AM	0	0	0	0	9	0	5	0	6	22	0	0	0	24	1	0	67	
11:50 AM	0	0	0	0	2	0	4	0	5	31	0	0	0	24	4	0	70	
11:55 AM	0	0	0	0	4	0	6	0	5	20	0	0	0	23	1	0	59	
12:00 PM	0	0	0	0	5	0	3	0	3	22	0	0	0	21	2	0	56	
12:05 PM	0	0	0	0	3	0	6	0	5	32	0	0	0	32	3	0	81	
12:10 PM	0	0	0	0	3	0	9	0	5	29	0	0	0	29	8	0	83	
12:15 PM	0	0	0	0	4	0	4	0	6	29	0	0	0	31	2	0	76	
12:20 PM	0	0	0	0	5	0	9	0	5	28	0	0	0	30	7	0	84	
12:25 PM	0	0	0	0	9	0	7	0	6	29	0	0	0	31	3	0	85	852
12:30 PM	0	0	0	0	5	0	3	0	2	35	0	0	0	25	2	0	72	869
12:35 PM	0	0	0	0	10	0	13	0	6	28	0	0	0	19	5	0	81	892
12:40 PM	0	0	0	0	6	0	7	0	8	29	0	0	0	33	6	0	89	903
12:45 PM	0	0	0	0	5	0	7	0	6	26	0	0	0	25	2	0	71	907
12:50 PM	0	0	0	0	5	0	3	0	7	25	0	0	0	28	6	0	74	911
12:55 PM	0	0	0	0	5	0	4	0	7	20	0	0	0	25	4	0	65	917
1:00 PM	0	0	0	0	1	0	4	0	7	27	0	0	0	33	7	0	79	940
1:05 PM	0	0	0	0	2	0	6	0	7	23	0	0	0	19	3	0	60	919
1:10 PM	0	0	0	0	7	0	2	0	4	33	0	0	0	23	7	0	76	912
1:15 PM	0	0	0	0	3	0	5	0	9	27	0	0	0	22	7	0	73	909
1:20 PM	0	0	0	0	1	0	4	0	8	22	0	0	0	28	4	0	67	892
1:25 PM	0	0	0	0	7	0	7	0	6	26	0	0	0	21	7	0	74	881
Peak 15-Min Flowrates	Northbound				Southbound				Eastbound				Westbound				Total	
	Left	Thru	Right	U	Left	Thru	Right	U	Left	Thru	Right	U	Left	Thru	Right	U		
All Vehicles	0	0	0	0	72	0	80	0	68	344	0	0	0	368	48	0	980	
Heavy Trucks	0	0	0	0	0	0	4	0	0	4	0	0	0	8	0	0	16	
Pedestrians	0	0	0	0	0	0	0	0	0	0	0	0	0	0	0	0	0	
Bicycles	0	0	0	0	1	0	0	0	0	0	0	0	0	0	0	0	1	
Railroad																		
Stopped Buses																		

Comments:

LOCATION: Seawell School Rd -- Estes Dr Ext
CITY/STATE: Chapel Hill, NC

QC JOB #: 14560321
DATE: Tue, Nov 14 2017

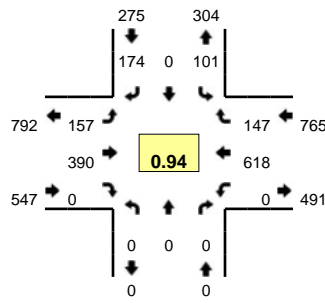

Peak-Hour: 4:55 PM -- 5:55 PM
Peak 15-Min: 5:20 PM -- 5:35 PM

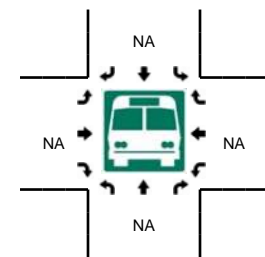
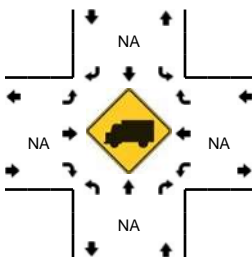
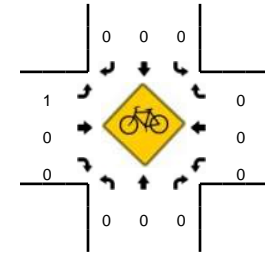
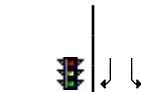
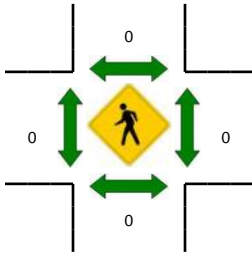
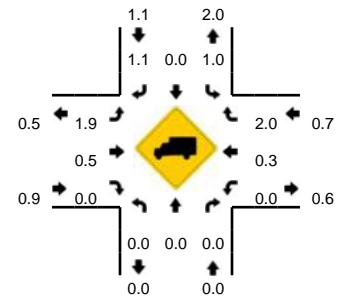

5-Min Count Period Beginning At	Seawell School Rd (Northbound)				Seawell School Rd (Southbound)				Estes Dr Ext (Eastbound)				Estes Dr Ext (Westbound)				Total	Hourly Totals
	Left	Thru	Right	U	Left	Thru	Right	U	Left	Thru	Right	U	Left	Thru	Right	U		
4:00 PM	0	0	0	0	10	0	19	0	12	33	0	0	0	34	9	0	117	
4:05 PM	0	0	0	0	19	0	20	0	12	30	0	0	0	45	6	0	132	
4:10 PM	0	0	0	0	13	0	16	0	2	33	0	0	0	38	11	0	113	
4:15 PM	0	0	0	0	8	0	17	0	11	33	0	0	0	42	12	0	123	
4:20 PM	0	0	0	0	9	0	19	0	22	27	0	0	0	48	7	0	132	
4:25 PM	0	0	0	0	5	0	12	0	14	25	0	0	0	39	13	0	108	
4:30 PM	0	0	0	0	8	0	5	0	11	26	0	0	0	54	11	0	115	
4:35 PM	0	0	0	0	4	0	9	0	21	32	0	0	0	57	13	0	136	
4:40 PM	0	0	0	0	10	0	6	0	22	27	0	0	0	48	13	0	126	
4:45 PM	0	0	0	0	4	0	6	0	11	28	0	0	0	56	19	0	124	
4:50 PM	0	0	0	0	6	0	6	0	10	32	0	0	0	49	10	0	113	
4:55 PM	0	0	0	0	5	0	11	0	17	31	0	0	0	42	11	0	117	1456
5:00 PM	0	0	0	0	7	0	9	0	5	37	0	0	0	40	15	0	113	1452
5:05 PM	0	0	0	0	16	0	14	0	11	36	0	0	0	43	13	0	133	1453
5:10 PM	0	0	0	0	12	0	25	0	16	35	0	0	0	51	12	0	151	1491
5:15 PM	0	0	0	0	13	0	11	0	16	35	0	0	0	48	9	0	132	1500
5:20 PM	0	0	0	0	6	0	24	0	8	28	0	0	0	55	10	0	131	1499
5:25 PM	0	0	0	0	7	0	20	0	11	28	0	0	0	60	15	0	141	1532
5:30 PM	0	0	0	0	4	0	12	0	25	34	0	0	0	65	12	0	152	1569
5:35 PM	0	0	0	0	5	0	11	0	15	34	0	0	0	50	11	0	126	1559
5:40 PM	0	0	0	0	13	0	13	0	9	30	0	0	0	52	15	0	132	1565
5:45 PM	0	0	0	0	2	0	14	0	13	34	0	0	0	66	13	0	142	1583
5:50 PM	0	0	0	0	11	0	10	0	11	28	0	0	0	46	11	0	117	1587
5:55 PM	0	0	0	0	2	0	16	0	6	31	0	0	0	34	12	0	101	1571
Peak 15-Min Flowrates	Northbound				Southbound				Eastbound				Westbound				Total	
	Left	Thru	Right	U	Left	Thru	Right	U	Left	Thru	Right	U	Left	Thru	Right	U		
All Vehicles	0	0	0	0	68	0	224	0	176	360	0	0	0	720	148	0	1696	
Heavy Trucks	0	0	0	0	4	0	8	0	4	4	0	0	0	0	0	0	20	
Pedestrians	0	0	0	0	0	0	0	0	0	0	0	0	0	0	0	0	0	
Bicycles	0	0	0	0	0	0	0	0	1	0	0	0	0	0	0	0	1	
Railroad	0	0	0	0	0	0	0	0	0	0	0	0	0	0	0	0	0	
Stopped Buses	0	0	0	0	0	0	0	0	0	0	0	0	0	0	0	0	0	

Comments:

Appendix C – Background Generator Information

2021 Total Background Traffic Volumes

12/12/17

Peak AM

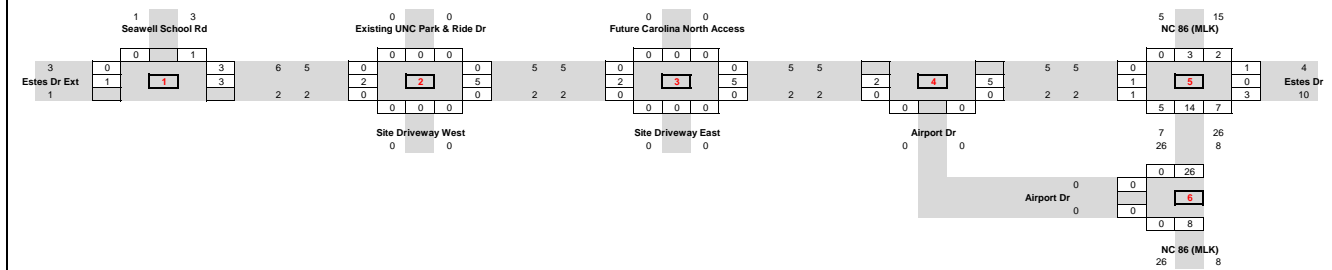

2021 Sawmill Trip Distribution %

Peak AM

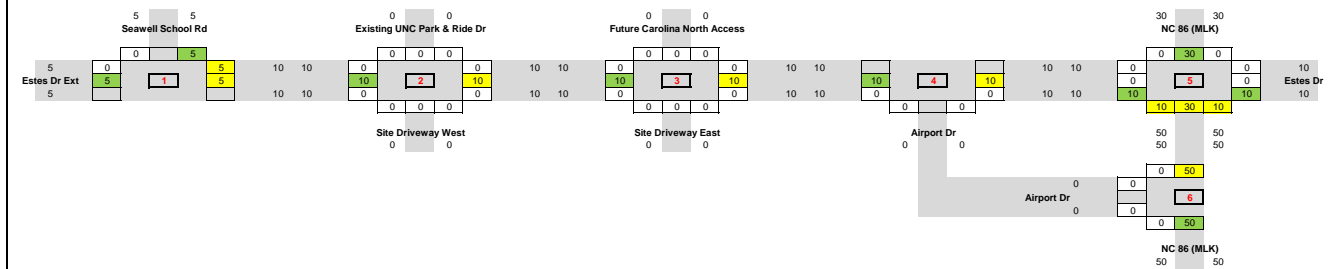

2021 Sawmill Background Traffic Volumes

Peak AM

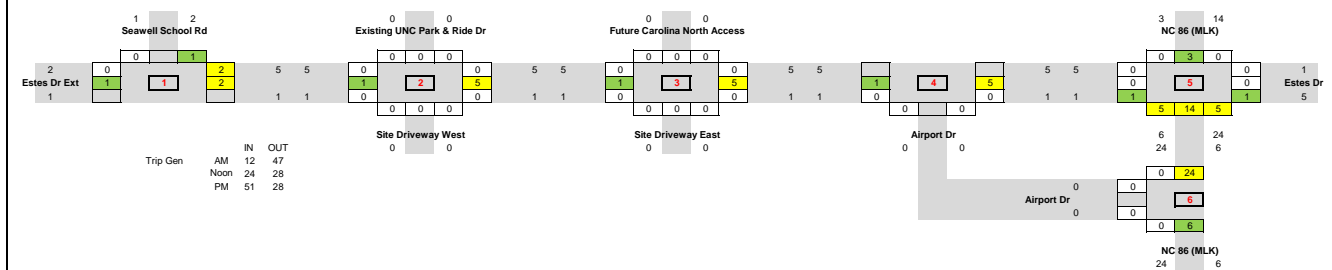

2021 Charlotte Retirement Residence Trip Distribution %

Peak AM

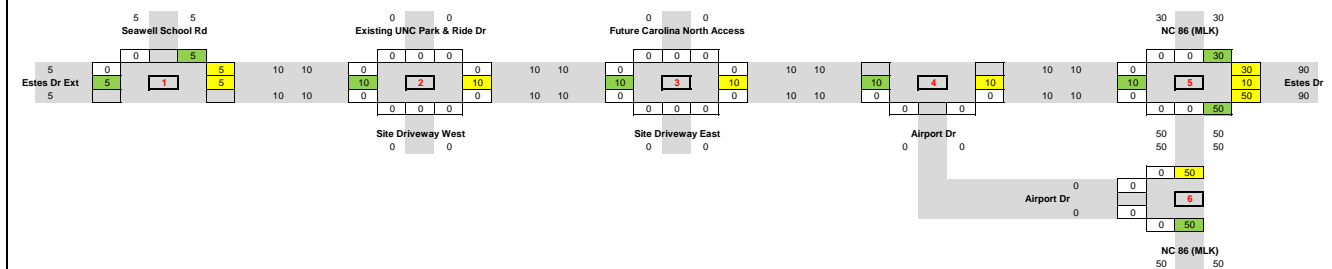

2021 Charlotte Retirement Residence Background Traffic Volumes

Peak AM

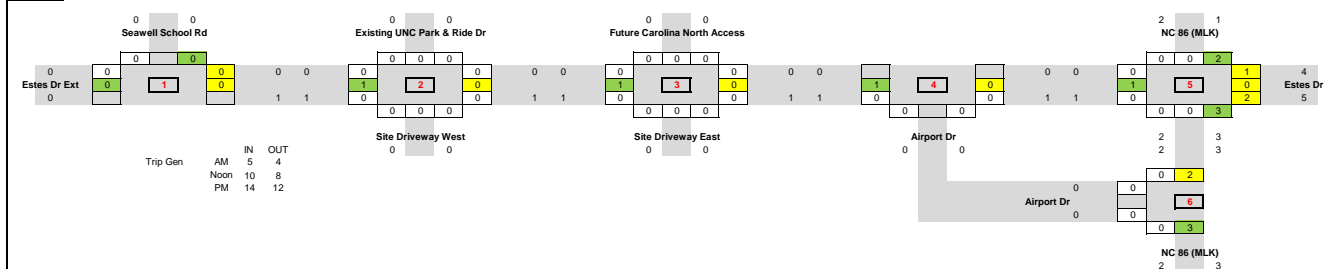

2021 Total Background Traffic Volumes

12/12/17

Peak Noon

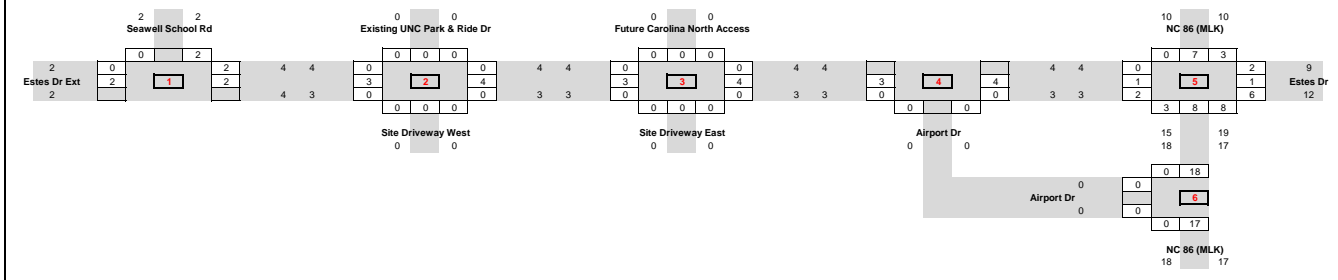

2021 Sawmill Trip Distribution %

Peak Noon

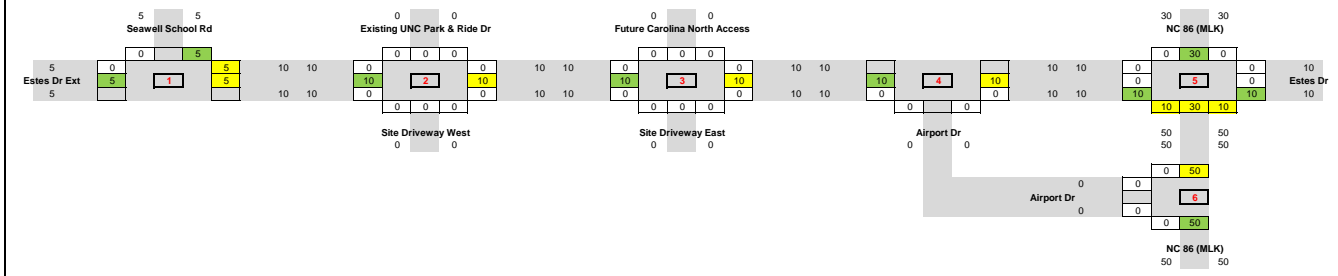

2021 Sawmill Background Traffic Volumes

Peak Noon

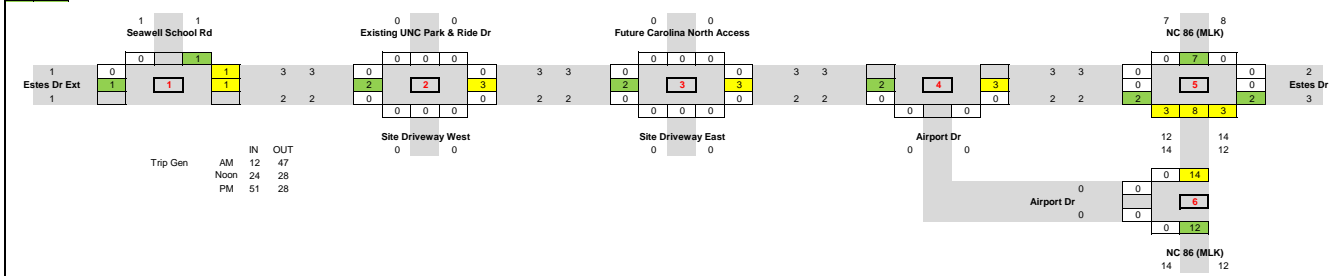

2021 Charlotte Retirement Residence Trip Distribution %

Peak Noon

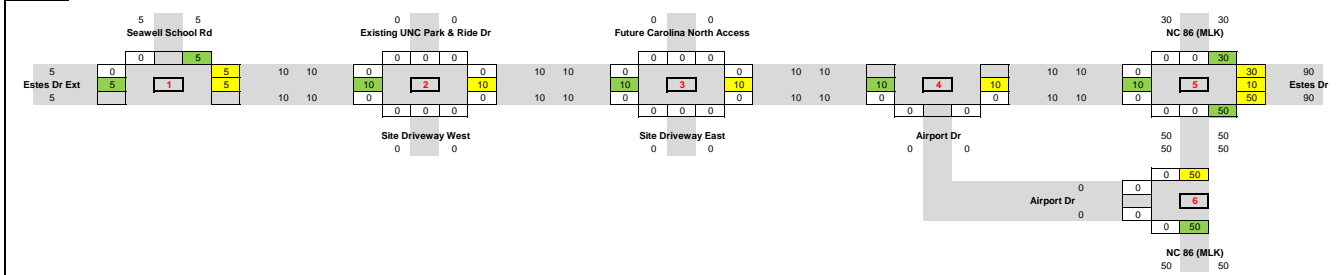

2021 Charlotte Retirement Residence Background Traffic Volumes

Peak Noon

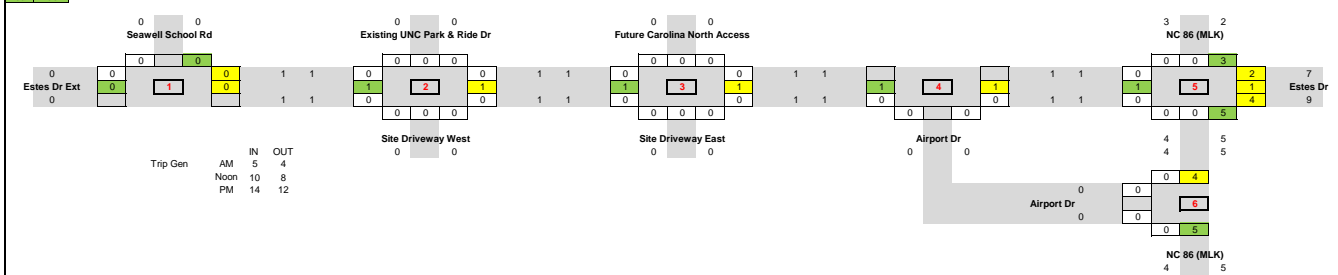

2021 Total Background Traffic Volumes

12/12/17

Peak PM

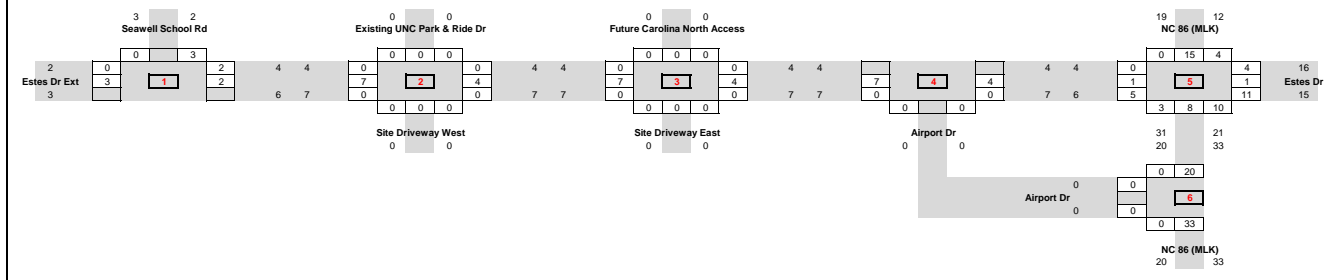

2021 Sawmill Trip Distribution %

Peak PM

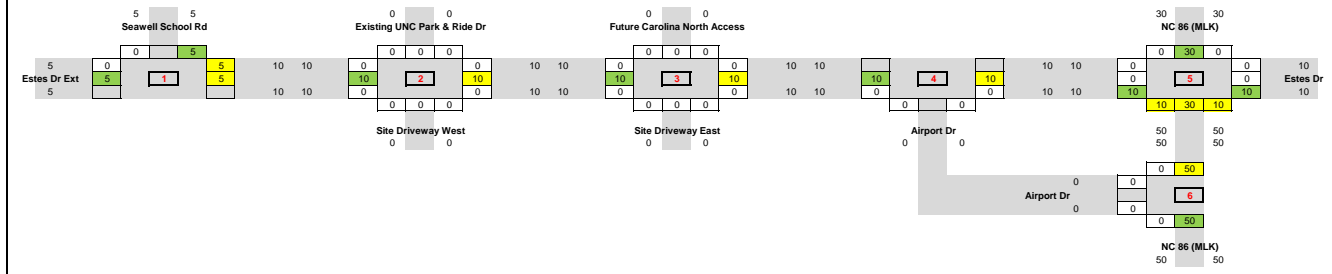

2021 Sawmill Background Traffic Volumes

Peak PM

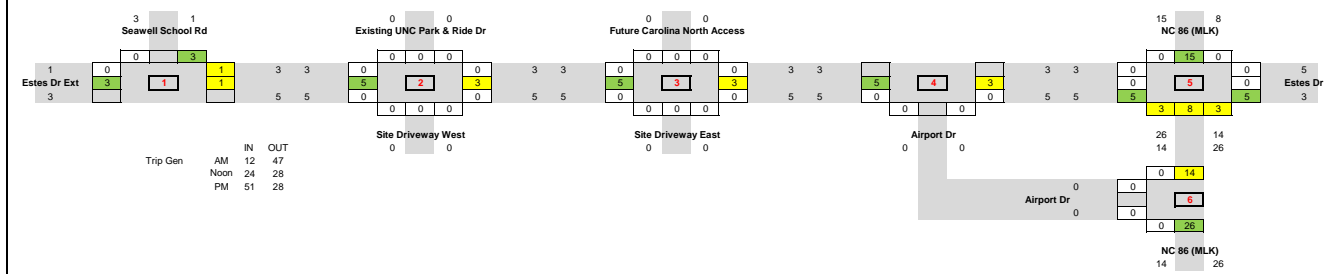

2021 Charlotte Retirement Residence Trip Distribution %

Peak PM

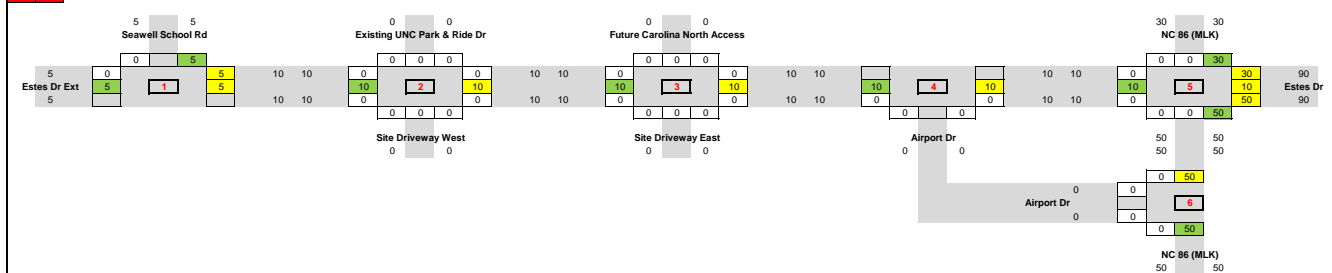

2021 Charlotte Retirement Residence Background Traffic Volumes

Peak PM

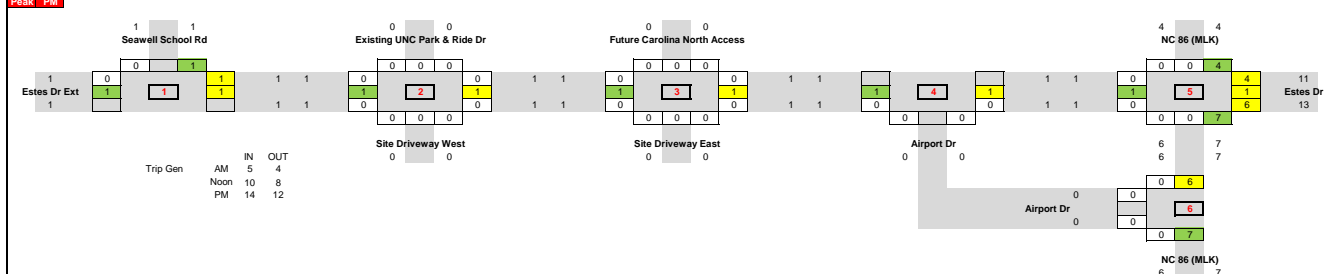

Appendix D - Traffic Volume Development
Spreadsheets

Chapel Hill Municipal Campus Trip Generation Results

Phase 1			Daily			AM Peak			Noon Peak			PM Peak		
ITE LUC	Description	Density	Enter	Exit	Total	Enter	Exit	Total	Enter	Exit	Total	Enter	Exit	Total
710	General Office Building	48467 SF	379	379	758	94	13	107	59	62	121	23	110	133
	Police Station - Field Data Adjusted	24346 SF	146	146	292	32	3	35	28	22	50	15	40	55
	Total Phase 1	72813 SF	525	525	1050	126	16	142	87	84	171	38	150	188

Existing			Daily			AM Peak			Noon Peak			PM Peak		
Description	Density		Enter	Exit	Total	Enter	Exit	Total	Enter	Exit	Total	Enter	Exit	Total
Police Station - Field Data	24000 SF					30	3	33	27	21	48	14	38	52
	5% Inc					32	3	35	28	22	50	15	40	55

Daily Estimate for Police Station	AM Ratio	Noon Ratio	PM Ratio	Weighted
	0.33	0.41	0.41	0.38

2017 Count Data

11/9/17

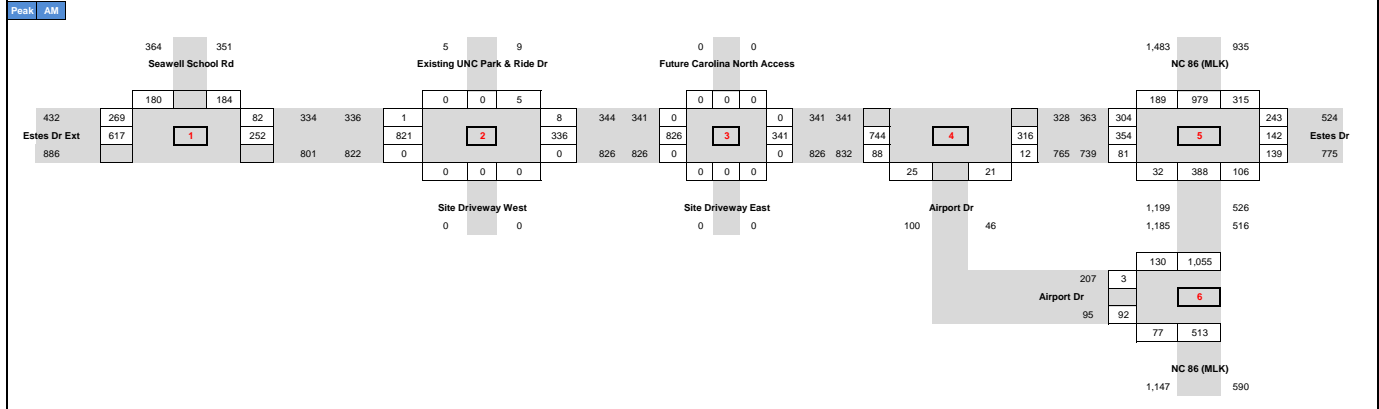

2021 Ambient Growth

Ambient Growth Rate/Yr = 1.0%
 Ambient Growth Total = 1.040

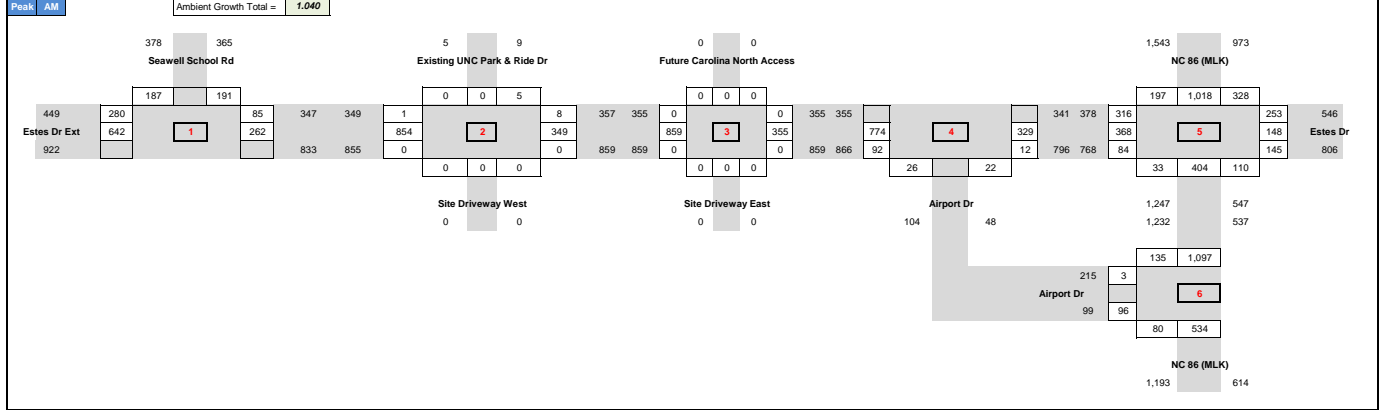

2021 Total Background Traffic Volumes

12/12/17

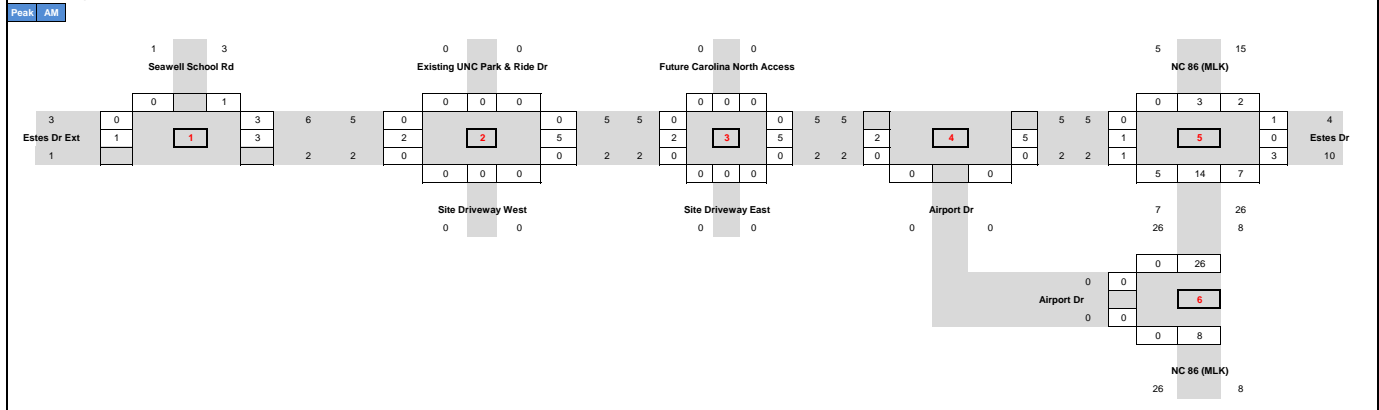

2021 Traffic Without Site

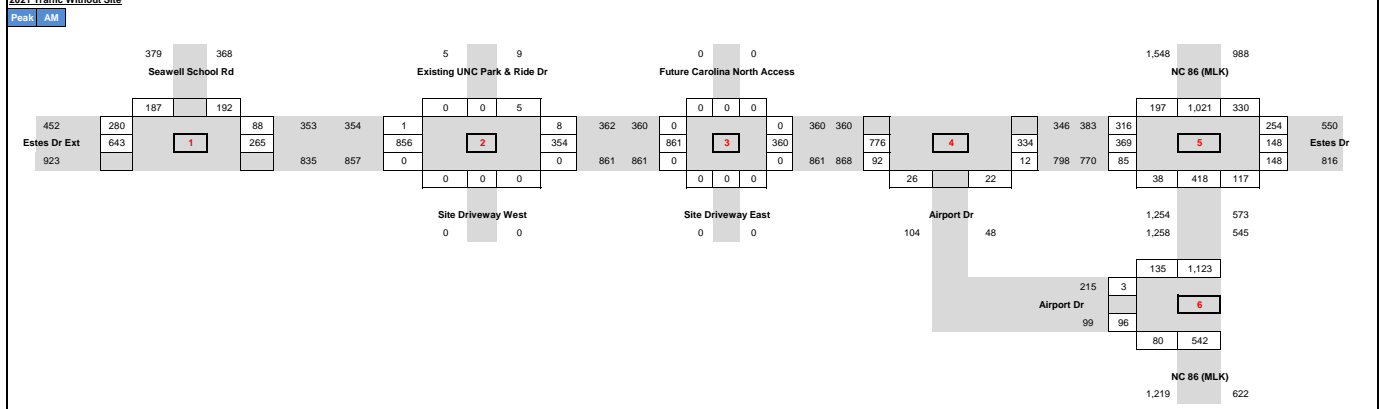

2021 Site Trip Distribution Percentages - Phase 1

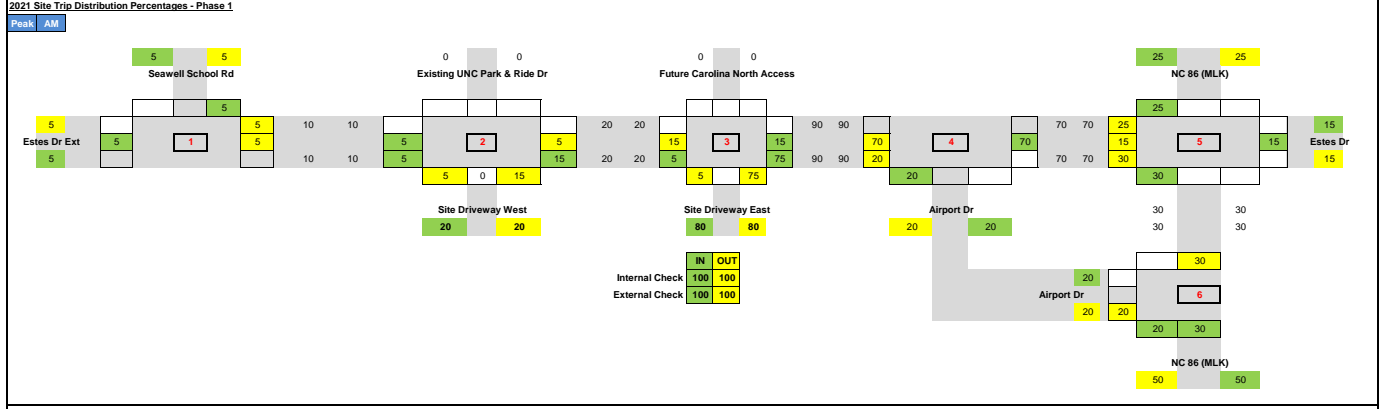

2021 Site Traffic Assignment - Phase 1

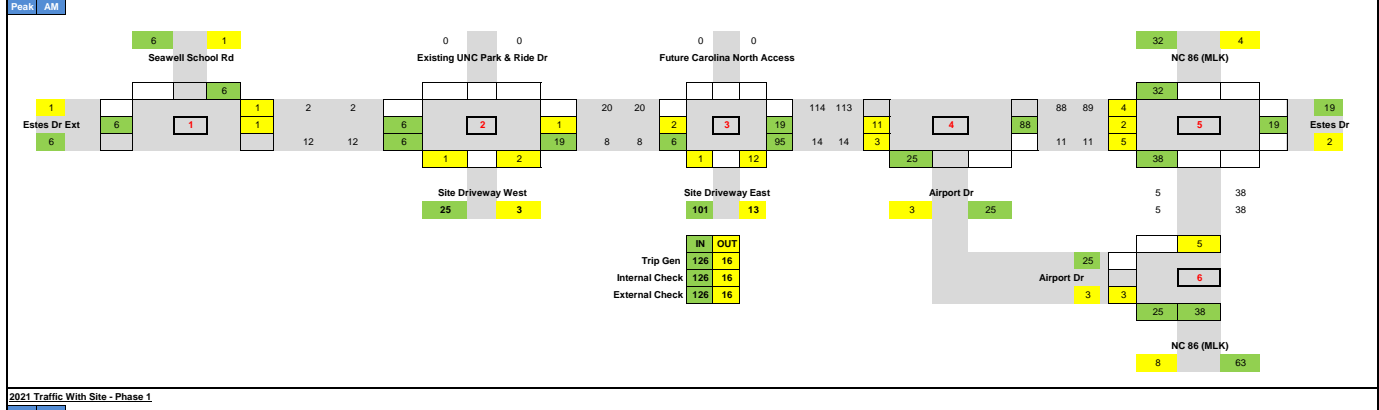

2021 Traffic With Site - Phase 1

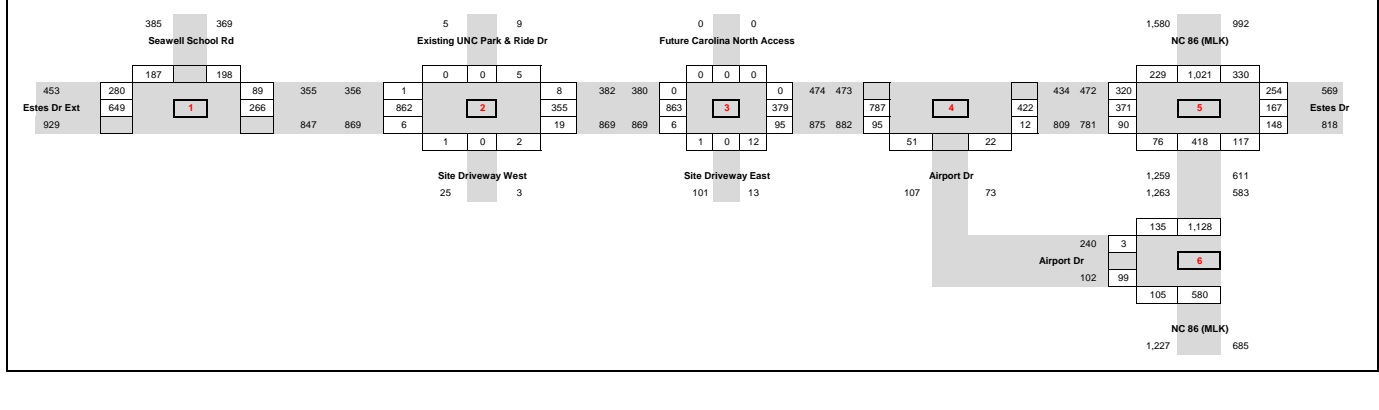

2017 Count Data

11/8/17

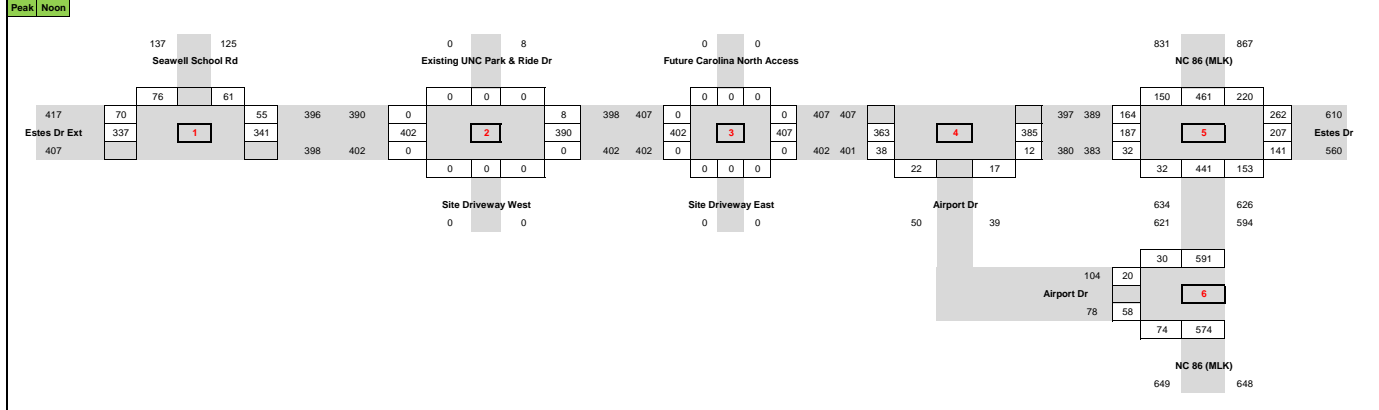

2021 Ambient Growth

Ambient Growth Rate/Yr	1.0%
Ambient Growth Total	1.040

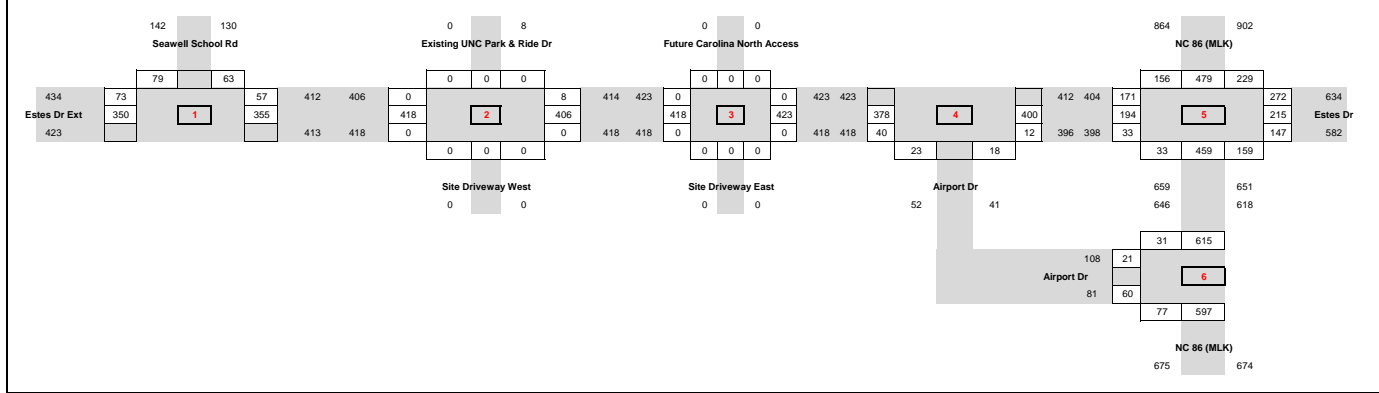

2021 Total Background Traffic Volumes

12/12/17

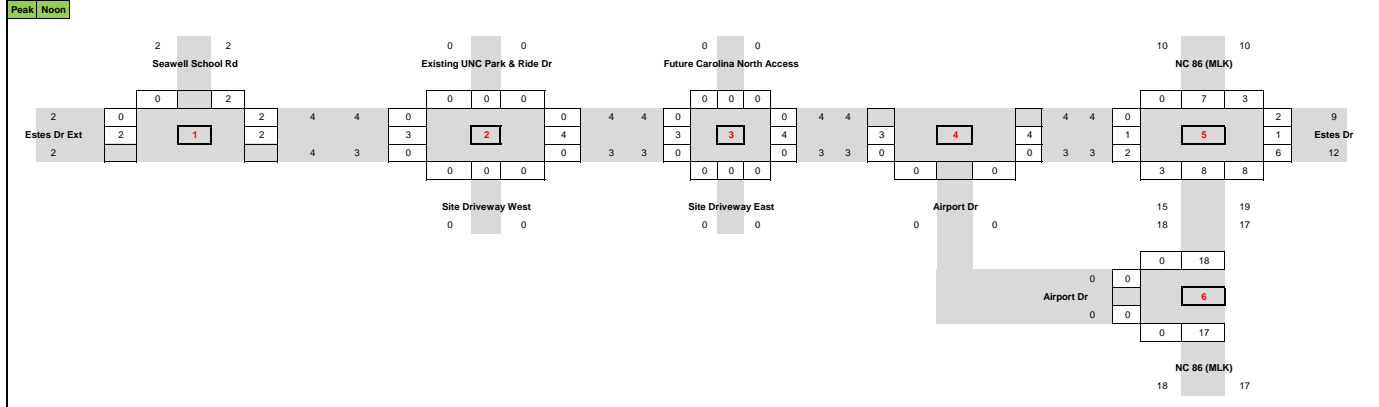

2021 Traffic Without Site

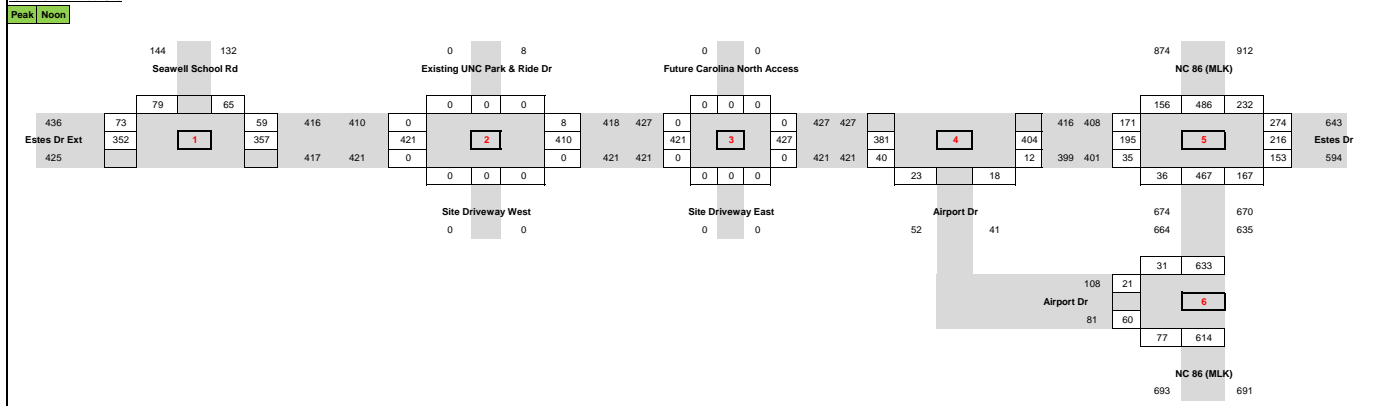

2021 Site Trip Distribution Percentages - Phase 1

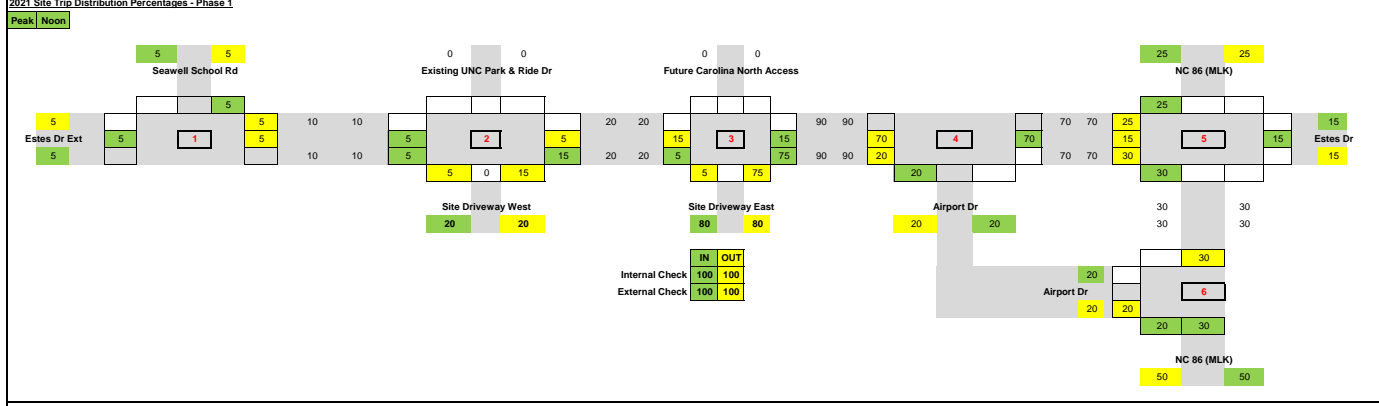

2021 Site Traffic Assignment - Phase 1

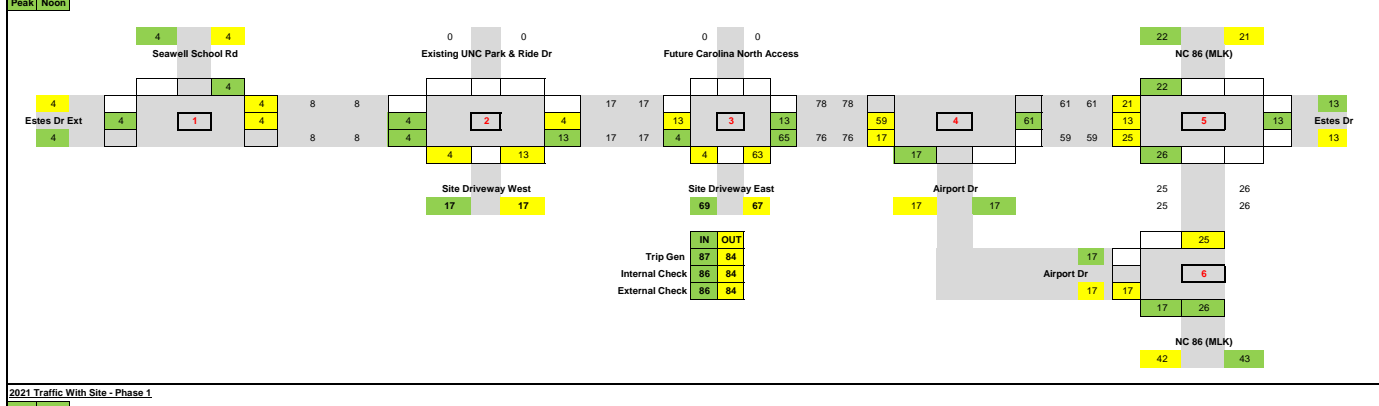

2021 Traffic With Site - Phase 1

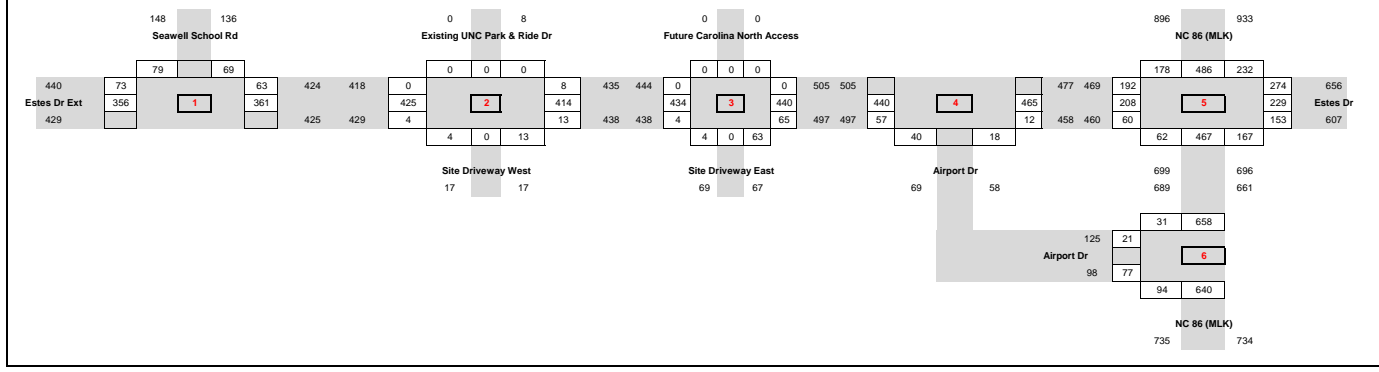

Appendix E – Synchro Signalized Capacity Analysis
Output

Lanes, Volumes, Timings
 1: Estes Drive Extension & Seawell School Road



+ ,	+	'	(+	(-	'
+ !							
. / 0	12	1	3&	3	4	1	
5 . / 0	12	1	3&	3	4	1	
6 5 / 0	&	&	&	&	&	&	
, 6 /70	87			7	87		
! + ! / 0	2		4				4
! +							
+ ! / 0	4		4				
+ 9 :5	:	:	:	:	:	:	:
5		:14					:14
5 # 6	:&4		:&4				
6:5 / 0	&	4&	4	13	1 &	423	
5 # 6	:&4		:&				
6:5 / 0	&	4&	1	13	1 &	423	
'! '6			((
6:5 / ;'0							
+ \$ 6 / 0	4			4	4		
+ \$ < / 0	13			324	14		
/0	3:1			:3	3:		
# \$ 5	:&	:&	:&	:&	:&	:&	
% . /70	7	7	7	7	37	37	
"6=: 5 / 0		&1	&3	3 1		&	
6+ /70							
+ , 5 / 0		&1	&3	3 1		&	
) \$6	((((((
+ " !	+	'!	+	+	+	'!	
6 -6 / 0							
+ \$; / 0							
\$ -6 / 0	3			3	3		
% + +							
6 % 5	:&1	:&1	:	:	:&1	:&1	
! 6 / 0	4	&	4			&	
%	#	#	>	("	("	>	
# 6 #	2		4		3	2	
# 6 #		2				3	
< #	2	2	4		3	2	
#							
/0	:	:	:	:	:	:	
/0	2:	2:	2:	&:	&:	2:	
/0	4:	4:	4:	4:	3:	4:	
/70	4:7	4:7	4:7	4:7	3:7	4:7	
? /0	:	:	:	4:	4:	:	
" 8'6 /0	:	:	:&	:	:	:	
+ "6= /0	8:2	8:2	:	8:	8:	8:2	
+ /0	4:	4:	4:	4:	4:	4:	
+ 6+!			+ 6		+!		
+ 68+!; @ A			?		?		
' 6	((((
" , /0	:3	:3	:1	:1	3:	2:2	

() (* # ! " # \$ % & ' # !

Lanes, Volumes, Timings
 1: Estes Drive Extension & Seawell School Road

12/13/2017

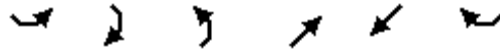

Lane Group	SEL	SER	NEL	NET	SWT	SWR
Actuated g/C Ratio	0.23	0.23	0.58	0.58	0.31	0.63
v/c Ratio	0.49	0.54	0.49	0.64	0.50	0.09
Control Delay	23.5	25.3	9.3	11.6	19.5	3.9
Queue Delay	0.0	0.0	0.0	0.0	0.0	0.0
Total Delay	23.5	25.3	9.3	11.6	19.5	3.9
LOS	C	C	A	B	B	A
Approach Delay	24.4			10.9	15.7	
Approach LOS	C			B	B	
Queue Length 50th (ft)	54	53	40	120	70	9
Queue Length 95th (ft)	127	128	100	283	150	20
Internal Link Dist (ft)	782			565	745	
Turn Bay Length (ft)	400		250			75
Base Capacity (vph)	667	597	608	1823	1728	1199
Starvation Cap Reductn	0	0	0	0	0	0
Spillback Cap Reductn	0	0	0	0	0	0
Storage Cap Reductn	0	0	0	0	0	0
Reduced v/c Ratio	0.30	0.33	0.49	0.37	0.16	0.08

Intersection Summary

Area Type:	Other
Cycle Length:	100
Actuated Cycle Length:	54.6
Natural Cycle:	50
Control Type:	Actuated-Uncoordinated
Maximum v/c Ratio:	0.64
Intersection Signal Delay:	15.0
Intersection LOS:	B
Intersection Capacity Utilization:	51.0%
ICU Level of Service:	A
Analysis Period (min):	15

Splits and Phases: 1: Estes Drive Extension & Seawell School Road



Lanes, Volumes, Timings

5: NC 86 (MLK Jr. Blvd) & Estes Drive Extension/Estes Drive

12/13/2017



Lane Group	EBL	EBT	EBR	WBL	WBT	WBR	NBL	NBT	NBR	SBL	SBT	SBR
Lane Configurations												
Traffic Volume (vph)	304	354	81	139	142	243	32	388	106	315	979	189
Future Volume (vph)	304	354	81	139	142	243	32	388	106	315	979	189
Ideal Flow (vphpl)	1900	1900	1900	1900	1900	1900	1900	1900	1900	1900	1900	1900
Grade (%)		0%			1%			1%				-2%
Storage Length (ft)	225		300	150		450	0		0	0		0
Storage Lanes	1		1	1		1	1		0	1		0
Taper Length (ft)	25			25			25			25		
Lane Util. Factor	1.00	1.00	1.00	1.00	1.00	1.00	1.00	0.95	0.95	1.00	0.95	0.95
Ped Bike Factor	1.00					0.99		0.99		0.99		
Frt			0.850			0.850		0.968				0.976
Flt Protected	0.950			0.950			0.950			0.950		
Satd. Flow (prot)	1770	1863	1583	1694	1783	1516	1678	3223	0	1770	3455	0
Flt Permitted	0.444			0.156			0.097			0.455		
Satd. Flow (perm)	827	1863	1583	278	1783	1497	171	3223	0	840	3455	0
Right Turn on Red			No			No			No			No
Satd. Flow (RTOR)												
Link Speed (mph)		35			35			35				35
Link Distance (ft)		1360			1121			1058				1059
Travel Time (s)		26.5			21.8			20.6				20.6
Confl. Peds. (#/hr)	1					1			7	7		
Peak Hour Factor	0.93	0.93	0.93	0.93	0.93	0.93	0.93	0.93	0.93	0.93	0.93	0.93
Heavy Vehicles (%)	2%	2%	2%	6%	6%	6%	7%	7%	7%	3%	3%	3%
Adj. Flow (vph)	327	381	87	149	153	261	34	417	114	339	1053	203
Shared Lane Traffic (%)												
Lane Group Flow (vph)	327	381	87	149	153	261	34	531	0	339	1256	0
Enter Blocked Intersection	No	No	No	No	No	No	No	No	No	No	No	No
Lane Alignment	Left	Left	Right	Left	Left	Right	Left	Left	Right	Left	Left	Right
Median Width(ft)		12			12			12				12
Link Offset(ft)		0			0			0				0
Crosswalk Width(ft)		16			16			16				16
Two way Left Turn Lane												
Headway Factor	1.00	1.00	1.00	1.01	1.01	1.01	1.01	1.01	1.01	0.99	0.99	0.99
Turning Speed (mph)	15		9	15		9	15		9	15		9
Turn Type	pm+pt	NA	pm+ov	pm+pt	NA	pm+ov	pm+pt	NA		pm+pt	NA	
Protected Phases	7	4	5	3	8	1	5	2		1	6	
Permitted Phases	4		4	8		8	2			6		
Detector Phase	7	4	5	3	8	1	5	2		1	6	
Switch Phase												
Minimum Initial (s)	7.0	7.0	7.0	7.0	7.0	7.0	7.0	12.0		7.0	12.0	
Minimum Split (s)	12.0	13.0	13.0	13.0	13.0	13.0	13.0	34.0		13.0	18.0	
Total Split (s)	25.0	40.0	20.0	25.0	40.0	35.0	20.0	50.0		35.0	65.0	
Total Split (%)	16.7%	26.7%	13.3%	16.7%	26.7%	23.3%	13.3%	33.3%		23.3%	43.3%	
Yellow Time (s)	3.0	3.8	3.0	3.0	3.8	3.0	3.0	4.3		3.0	4.3	
All-Red Time (s)	1.9	1.7	2.8	2.4	1.7	2.8	2.8	1.7		2.8	1.7	
Lost Time Adjust (s)	0.1	-0.5	-0.8	-0.4	-0.5	-0.8	-0.8	-1.0		-0.8	-1.0	
Total Lost Time (s)	5.0	5.0	5.0	5.0	5.0	5.0	5.0	5.0		5.0	5.0	
Lead/Lag	Lead	Lag	Lead	Lead	Lag	Lag	Lead	Lead		Lag	Lag	
Lead-Lag Optimize?	Yes	Yes	Yes	Yes	Yes	Yes	Yes	Yes		Yes	Yes	

Lanes, Volumes, Timings

5: NC 86 (MLK Jr. Blvd) & Estes Drive Extension/Estes Drive

12/13/2017



Lane Group	EBL	EBT	EBR	WBL	WBT	WBR	NBL	NBT	NBR	SBL	SBT	SBR
Recall Mode	None	None	None	None	None	None	None	C-Max		None	C-Max	
Act Effect Green (s)	53.4	34.6	48.5	44.7	29.7	59.7	50.3	50.3		71.5	71.5	
Actuated g/C Ratio	0.36	0.23	0.32	0.30	0.20	0.40	0.34	0.34		0.48	0.48	
v/c Ratio	0.78	0.89	0.17	0.67	0.43	0.44	0.23	0.49		0.58	0.76	
Control Delay	51.3	78.0	36.3	47.4	55.5	20.2	40.7	42.7		40.1	37.4	
Queue Delay	0.0	0.0	0.0	0.0	0.0	0.0	0.0	0.0		0.0	0.0	
Total Delay	51.3	78.0	36.3	47.4	55.5	20.2	40.7	42.7		40.1	37.4	
LOS	D	E	D	D	E	C	D	D		D	D	
Approach Delay		62.5			37.0			42.6			38.0	
Approach LOS		E			D			D			D	
Queue Length 50th (ft)	242	354	60	98	130	113	23	223		218	538	
Queue Length 95th (ft)	327	#541	104	149	198	156	52	291		323	677	
Internal Link Dist (ft)		1280			1041			978			979	
Turn Bay Length (ft)	225		300	150		450						
Base Capacity (vph)	419	449	576	280	416	599	208	1080		586	1645	
Starvation Cap Reductn	0	0	0	0	0	0	0	0		0	0	
Spillback Cap Reductn	0	0	0	0	0	0	0	0		0	0	
Storage Cap Reductn	0	0	0	0	0	0	0	0		0	0	
Reduced v/c Ratio	0.78	0.85	0.15	0.53	0.37	0.44	0.16	0.49		0.58	0.76	

Intersection Summary

Area Type: Other
 Cycle Length: 150
 Actuated Cycle Length: 150
 Offset: 91 (61%), Referenced to phase 2:NBT and 6:SBTL, Start of Green
 Natural Cycle: 90
 Control Type: Actuated-Coordinated
 Maximum v/c Ratio: 0.89
 Intersection Signal Delay: 44.1
 Intersection LOS: D
 Intersection Capacity Utilization 83.8%
 ICU Level of Service E
 Analysis Period (min) 15
 # 95th percentile volume exceeds capacity, queue may be longer.
 Queue shown is maximum after two cycles.

Splits and Phases: 5: NC 86 (MLK Jr. Blvd) & Estes Drive Extension/Estes Drive



Lanes, Volumes, Timings
 1: Estes Drive Extension & Seawell School Road



* +	*	'	"*	"	,	!	
* !	↖	↗	↖	↗	↖	↗	↖
- . /	0	0			1	22	
3 - . /	0	0			1	22	
4 3 . /	&	&	&	&	&	&	
+ 4 .5/	65				5	65	
! * ! . /	1		2				2
! *							
* ! . /	2		2				
* 7 8 3	8	8	8	8	8	8	
3		892					892
3 # 4	8&2		8&2				
48 3 . /	&	2&	2	90	9	2&	
3 # 4	8&2		81				
48 3 . /	&	2&		90	9	2&	
' ! ' 4			"				"
48 3 . : /							
* \$ 4 . /	2			2	2		
* \$; . /	90			012	92		
. /	089			80	08		
# \$ 3	8&0	8&0	8&0	8&0	8&0	8&0	8&0
% - .5/	5	5	5	5	5	5	
<4=8 3 . /	01	&		2	22	2	
4 * .5/							
* + 3 . /	01	&		2	22	2	
(\$ 4	"	"	"	"	"	"	"
* < !	*	'!	*	*	*	'!	
4 , 4 . /							
* \$: . /							
\$, 4 . /	0			0	0		
% * *							
4 % 3	8&9	8&9	8	8	8&9	8&9	
! 4 . /	2	&	2			&	
%	#	#	>	"<	"<	>	
# 4 #	1		2		0	1	
# 4 #		1				0	
; #	1	1	2		0	1	
#							
. /	8	8	8	8	8	8	
. /	18	18	18	&8	&8	18	
. /	28	28	28	28	0 8	28	
.5/	28 5	28 5	28 5	28 5	0 8 5	28 5	
? . /	8	8	8	28	28	8	
< 6' 4 . /	8	8	8&	8	8	8	
* <4= . /	6 81	6 81	8	6 8	6 8	6 81	
* . /	28	28	28	28	28	28	
* 4 * !			* 4		* !		
* 46 * ! : @ A			?		?		
' 4	"	"	"		"		
< + . /	989	989	08&	98	82	8	

" (") # ! " # \$ % & ' # !

Lanes, Volumes, Timings
 1: Estes Drive Extension & Seawell School Road

12/13/2017



Lane Group	SEL	SER	NEL	NET	SWT	SWR
Actuated g/C Ratio	0.20	0.20	0.63	0.65	0.50	0.78
v/c Ratio	0.18	0.24	0.11	0.29	0.38	0.05
Control Delay	18.7	19.6	4.5	5.4	12.9	3.3
Queue Delay	0.0	0.0	0.0	0.0	0.0	0.0
Total Delay	18.7	19.6	4.5	5.4	12.9	3.3
LOS	B	B	A	A	B	A
Approach Delay	19.2			5.2	11.6	
Approach LOS	B			A	B	
Queue Length 50th (ft)	14	18	6	37	73	5
Queue Length 95th (ft)	46	55	19	79	155	14
Internal Link Dist (ft)	782			565	745	
Turn Bay Length (ft)	400		250			75
Base Capacity (vph)	874	781	703	1826	1860	1453
Starvation Cap Reductn	0	0	0	0	0	0
Spillback Cap Reductn	0	0	0	0	0	0
Storage Cap Reductn	0	0	0	0	0	0
Reduced v/c Ratio	0.07	0.10	0.10	0.19	0.19	0.04

Intersection Summary

Area Type:	Other
Cycle Length:	100
Actuated Cycle Length:	43
Natural Cycle:	50
Control Type:	Actuated-Uncoordinated
Maximum v/c Ratio:	0.38
Intersection Signal Delay:	9.9
Intersection LOS:	A
Intersection Capacity Utilization:	42.1%
ICU Level of Service:	A
Analysis Period (min):	15

Splits and Phases: 1: Estes Drive Extension & Seawell School Road



Lanes, Volumes, Timings

5: NC 86 (MLK Jr. Blvd) & Estes Drive Extension/Estes Drive

12/13/2017

Lane Group	EBL	EBT	EBR	WBL	WBT	WBR	NBL	NBT	NBR	SBL	SBT	SBR
Lane Configurations												
Traffic Volume (vph)	164	187	32	141	207	262	32	441	153	220	461	150
Future Volume (vph)	164	187	32	141	207	262	32	441	153	220	461	150
Ideal Flow (vphpl)	1900	1900	1900	1900	1900	1900	1900	1900	1900	1900	1900	1900
Grade (%)		0%			1%			1%			-2%	
Storage Length (ft)	225		300	150		450	0		0	0		0
Storage Lanes	1		1	1		1	1		0	1		0
Taper Length (ft)	25			25			25			25		
Lane Util. Factor	1.00	1.00	1.00	1.00	1.00	1.00	1.00	0.95	0.95	1.00	0.95	0.95
Ped Bike Factor								0.99		1.00		
Frt			0.850			0.850		0.961			0.963	
Flt Protected	0.950			0.950			0.950			0.950		
Satd. Flow (prot)	1736	1827	1553	1727	1818	1545	1694	3230	0	1753	3376	0
Flt Permitted	0.228			0.348			0.322			0.412		
Satd. Flow (perm)	417	1827	1553	633	1818	1545	574	3230	0	757	3376	0
Right Turn on Red			No			No			No			No
Satd. Flow (RTOR)												
Link Speed (mph)		35			35			35				35
Link Distance (ft)		1360			1121			1058				1059
Travel Time (s)		26.5			21.8			20.6				20.6
Confl. Peds. (#/hr)									4	4		
Peak Hour Factor	0.96	0.96	0.96	0.96	0.96	0.96	0.96	0.96	0.96	0.96	0.96	0.96
Heavy Vehicles (%)	4%	4%	4%	4%	4%	4%	6%	6%	6%	4%	4%	4%
Adj. Flow (vph)	171	195	33	147	216	273	33	459	159	229	480	156
Shared Lane Traffic (%)												
Lane Group Flow (vph)	171	195	33	147	216	273	33	618	0	229	636	0
Enter Blocked Intersection	No	No	No	No	No	No	No	No	No	No	No	No
Lane Alignment	Left	Left	Right	Left	Left	Right	Left	Left	Right	Left	Left	Right
Median Width(ft)		12			12			12			12	
Link Offset(ft)		0			0			0			0	
Crosswalk Width(ft)		16			16			16			16	
Two way Left Turn Lane												
Headway Factor	1.00	1.00	1.00	1.01	1.01	1.01	1.01	1.01	1.01	0.99	0.99	0.99
Turning Speed (mph)	15		9	15		9	15		9	15		9
Turn Type	pm+pt	NA	pm+ov	pm+pt	NA	pm+ov	pm+pt	NA		pm+pt	NA	
Protected Phases	7	4	5	3	8	1	5	2		1	6	
Permitted Phases	4		4	8		8	2			6		
Detector Phase	7	4	5	3	8	1	5	2		1	6	
Switch Phase												
Minimum Initial (s)	7.0	7.0	7.0	7.0	7.0	7.0	7.0	12.0		7.0	12.0	
Minimum Split (s)	12.0	13.0	13.0	13.0	13.0	13.0	13.0	34.0		13.0	18.0	
Total Split (s)	25.0	30.0	25.0	25.0	30.0	25.0	25.0	80.0		25.0	80.0	
Total Split (%)	15.6%	18.8%	15.6%	15.6%	18.8%	15.6%	15.6%	50.0%		15.6%	50.0%	
Yellow Time (s)	3.0	3.8	3.0	3.0	3.8	3.0	3.0	4.3		3.0	4.3	
All-Red Time (s)	1.9	1.7	2.8	2.4	1.7	2.8	2.8	1.7		2.8	1.7	
Lost Time Adjust (s)	0.1	-0.5	-0.8	-0.4	-0.5	-0.8	-0.8	-1.0		-0.8	-1.0	
Total Lost Time (s)	5.0	5.0	5.0	5.0	5.0	5.0	5.0	5.0		5.0	5.0	
Lead/Lag	Lead	Lag	Lead	Lead	Lag	Lag	Lead	Lead		Lag	Lag	
Lead-Lag Optimize?	Yes	Yes	Yes	Yes	Yes	Yes	Yes	Yes		Yes	Yes	

Lanes, Volumes, Timings

5: NC 86 (MLK Jr. Blvd) & Estes Drive Extension/Estes Drive

12/13/2017



Lane Group	EBL	EBT	EBR	WBL	WBT	WBR	NBL	NBT	NBR	SBL	SBT	SBR
Recall Mode	None	None	None	None	None	None	None	C-Max		None	C-Max	
Act Effect Green (s)	41.3	24.0	37.4	39.0	22.9	42.9	79.9	79.9		94.0	94.0	
Actuated g/C Ratio	0.26	0.15	0.23	0.24	0.14	0.27	0.50	0.50		0.59	0.59	
v/c Ratio	0.69	0.71	0.09	0.56	0.83	0.66	0.10	0.38		0.40	0.32	
Control Delay	59.3	79.4	47.3	52.5	91.9	43.1	23.2	26.5		25.2	18.7	
Queue Delay	0.0	0.0	0.0	0.0	0.0	0.0	0.0	0.0		0.0	0.0	
Total Delay	59.3	79.4	47.3	52.5	91.9	43.1	23.2	26.5		25.2	18.7	
LOS	E	E	D	D	F	D	C	C		C	B	
Approach Delay		68.1			61.9			26.3			20.4	
Approach LOS		E			E			C			C	
Queue Length 50th (ft)	140	193	27	118	219	186	18	215		119	186	
Queue Length 95th (ft)	207	289	58	180	#338	260	40	273		181	242	
Internal Link Dist (ft)		1280			1041			978			979	
Turn Bay Length (ft)	225		300	150		450						
Base Capacity (vph)	277	293	475	304	284	414	426	1612		569	1983	
Starvation Cap Reductn	0	0	0	0	0	0	0	0		0	0	
Spillback Cap Reductn	0	0	0	0	0	0	0	0		0	0	
Storage Cap Reductn	0	0	0	0	0	0	0	0		0	0	
Reduced v/c Ratio	0.62	0.67	0.07	0.48	0.76	0.66	0.08	0.38		0.40	0.32	

Intersection Summary

Area Type: Other
 Cycle Length: 160
 Actuated Cycle Length: 160
 Offset: 104 (65%), Referenced to phase 2:NBTL and 6:SBTL, Start of Green
 Natural Cycle: 75
 Control Type: Actuated-Coordinated
 Maximum v/c Ratio: 0.83
 Intersection Signal Delay: 39.7
 Intersection LOS: D
 Intersection Capacity Utilization 72.2%
 ICU Level of Service C
 Analysis Period (min) 15
 # 95th percentile volume exceeds capacity, queue may be longer.
 Queue shown is maximum after two cycles.

Splits and Phases: 5: NC 86 (MLK Jr. Blvd) & Estes Drive Extension/Estes Drive

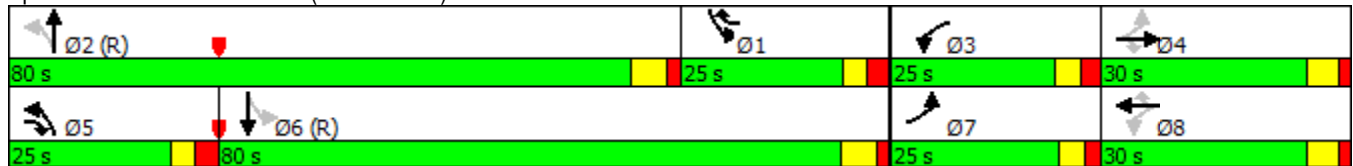

Lanes, Volumes, Timings
 1: Estes Drive Extension & Seawell School Road



* +	*	&	'*	'	,	&
* !	0	1	%	23	0	
4 - . /	0	1	%	23	0	
5 4 . /	%	%	%	%	%	%
+ 5 .6/	76			6	76	
! * ! . /	0		1			1
! *						
* ! . /	1		1			
* 8 94	9	9	9	9	9	9
4		931				931
4 " 5	9%1		9%1			
59 4 . /	%2	2	1	300	3%	2
4 " 5	9%1		9 2			
59 4 . /	%2	2	%	300	3%	2
&! & 5						
59 4 .& :&/						
* # 5 . /	1		1	1		
* #; . /	32			201	31	
. /	293			92	29	
" # 4	9%0	9%0	9%0	9%0	9%0	9%0
<5=9 4 . /		31	2	0 1	21	12
5 * .6/						
* + 4 . /	31	2	0 1	21	12	
(# 5						
* < !	*	&!*	*	*	*	&!*
5 , 5 . /						
* #: . /						
# , 5 . /	2			2	2	
\$ * *						
5 \$ 4	9%3	9%3	9	9	9%3	9%3
! 5 . /	1	%	1			%
\$	"	"	>	'<	'<	>
" 5 "	0		1		2	0
" 5 "		0				2
; "	0	0	1		2	0
"						
. /	9	9	9	9	9	9
. /	09	09	09	%9	%9	09
. /	19	19	19	19	2 9	19
.6/	19 6	19 6	19 6	19 6	2 9 6	19 6
? . /	9	9	9	19	19	9
< 7& 5 . /	9	9	9%	9	9	9
* <5= . /	7 90	7 90	9	7 9	7 9	7 90
* . /	19	19	19	19	19	19
* 5 *!			* 5		*!	
* 57*! : @ A			?		?	
& 5						
< + . /	93	93	029	029	9%	1 9%
< 5! &	9 %	9 %	922	922	901	9

!" "#

\$ %&

"!

'()"

Lanes, Volumes, Timings
 1: Estes Drive Extension & Seawell School Road

12/13/2017



Lane Group	SEL	SER	NEL	NET	SWT	SWR
v/c Ratio	0.31	0.59	0.43	0.34	0.77	0.14
Control Delay	30.3	37.4	8.3	6.4	23.6	3.1
Queue Delay	0.0	0.0	0.0	0.0	0.0	0.0
Total Delay	30.3	37.4	8.3	6.4	23.6	3.1
LOS	C	D	A	A	C	A
Approach Delay	34.8			7.0	19.6	
Approach LOS	C			A	B	
Queue Length 50th (ft)	40	73	23	66	229	17
Queue Length 95th (ft)	102	170	53	134	397	30
Internal Link Dist (ft)	782			565	745	
Turn Bay Length (ft)	400		250			75
Base Capacity (vph)	533	477	411	1697	1494	1318
Starvation Cap Reductn	0	0	0	0	0	0
Spillback Cap Reductn	0	0	0	0	0	0
Storage Cap Reductn	0	0	0	0	0	0
Reduced v/c Ratio	0.20	0.39	0.41	0.24	0.44	0.12

Intersection Summary

Area Type:	Other
Cycle Length:	100
Actuated Cycle Length:	71
Natural Cycle:	60
Control Type:	Actuated-Uncoordinated
Maximum v/c Ratio:	0.77
Intersection Signal Delay:	17.9
Intersection LOS:	B
Intersection Capacity Utilization:	59.6%
ICU Level of Service:	B
Analysis Period (min):	15

Splits and Phases: 1: Estes Drive Extension & Seawell School Road



Lanes, Volumes, Timings

5: NC 86 (MLK Jr. Blvd) & Estes Drive Extension/Estes Drive

12/13/2017



Lane Group	EBL	EBT	EBR	WBL	WBT	WBR	NBL	NBT	NBR	SBL	SBT	SBR
Lane Configurations												
Traffic Volume (vph)	273	238	71	156	296	423	81	1081	163	234	659	297
Future Volume (vph)	273	238	71	156	296	423	81	1081	163	234	659	297
Ideal Flow (vphpl)	1900	1900	1900	1900	1900	1900	1900	1900	1900	1900	1900	1900
Grade (%)		0%			1%			1%				-2%
Storage Length (ft)	225		300	150		450	0		0	0		0
Storage Lanes	1		1	1		1	1		0	1		0
Taper Length (ft)	25			25			25			25		
Lane Util. Factor	1.00	1.00	1.00	1.00	1.00	1.00	1.00	0.95	0.95	1.00	0.95	0.95
Ped Bike Factor								1.00				
Fr _t			0.850			0.850		0.980			0.953	
Fl _t Protected	0.950			0.950			0.950			0.950		
Satd. Flow (prot)	1770	1863	1583	1761	1853	1575	1761	3435	0	1787	3407	0
Fl _t Permitted	0.116			0.371			0.146			0.102		
Satd. Flow (perm)	216	1863	1583	688	1853	1575	271	3435	0	192	3407	0
Right Turn on Red			No			No			No			No
Satd. Flow (RTOR)												
Link Speed (mph)		35			35			35			35	
Link Distance (ft)		1360			1121			1058			1059	
Travel Time (s)		26.5			21.8			20.6			20.6	
Confl. Peds. (#/hr)									5	5		
Peak Hour Factor	0.95	0.95	0.95	0.95	0.95	0.95	0.95	0.95	0.95	0.95	0.95	0.95
Adj. Flow (vph)	287	251	75	164	312	445	85	1138	172	246	694	313
Shared Lane Traffic (%)												
Lane Group Flow (vph)	287	251	75	164	312	445	85	1310	0	246	1007	0
Enter Blocked Intersection	No	No	No	No	No	No	No	No	No	No	No	No
Lane Alignment	Left	Left	Right	Left	Left	Right	Left	Left	Right	Left	Left	Right
Median Width(ft)		12			12			12			12	
Link Offset(ft)		0			0			0			0	
Crosswalk Width(ft)		16			16			16			16	
Two way Left Turn Lane												
Headway Factor	1.00	1.00	1.00	1.01	1.01	1.01	1.01	1.01	1.01	0.99	0.99	0.99
Turning Speed (mph)	15		9	15		9	15		9	15		9
Turn Type	pm+pt	NA	pm+ov	pm+pt	NA	pm+ov	pm+pt	NA		pm+pt	NA	
Protected Phases	7	4	5	3	8	1	5	2		1	6	
Permitted Phases	4		4	8		8	2			6		
Detector Phase	7	4	5	3	8	1	5	2		1	6	
Switch Phase												
Minimum Initial (s)	7.0	7.0	7.0	7.0	7.0	7.0	7.0	12.0		7.0	12.0	
Minimum Split (s)	12.0	13.0	13.0	13.0	13.0	13.0	13.0	34.0		13.0	18.0	
Total Split (s)	30.0	35.0	25.0	30.0	35.0	25.0	25.0	90.0		25.0	90.0	
Total Split (%)	16.7%	19.4%	13.9%	16.7%	19.4%	13.9%	13.9%	50.0%		13.9%	50.0%	
Yellow Time (s)	3.0	3.8	3.0	3.0	3.8	3.0	3.0	4.3		3.0	4.3	
All-Red Time (s)	1.9	1.7	2.8	2.4	1.7	2.8	2.8	1.7		2.8	1.7	
Lost Time Adjust (s)	0.1	-0.5	-0.8	-0.4	-0.5	-0.8	-0.8	-1.0		-0.8	-1.0	
Total Lost Time (s)	5.0	5.0	5.0	5.0	5.0	5.0	5.0	5.0		5.0	5.0	
Lead/Lag	Lead	Lag	Lead	Lead	Lag	Lag	Lead	Lead		Lag	Lag	
Lead-Lag Optimize?	Yes	Yes	Yes	Yes	Yes	Yes	Yes	Yes		Yes	Yes	
Recall Mode	None	None	None	None	None	None	None	C-Max		None	C-Max	

Lanes, Volumes, Timings

5: NC 86 (MLK Jr. Blvd) & Estes Drive Extension/Estes Drive

12/13/2017



Lane Group	EBL	EBT	EBR	WBL	WBT	WBR	NBL	NBT	NBR	SBL	SBT	SBR
Act Effect Green (s)	59.0	36.7	52.8	48.3	30.0	50.0	85.0	85.0		93.9	93.9	
Actuated g/C Ratio	0.33	0.20	0.29	0.27	0.17	0.28	0.47	0.47		0.52	0.52	
v/c Ratio	1.00	0.66	0.16	0.56	1.01	1.02	0.39	0.81		0.89	0.57	
Control Delay	108.3	75.9	49.1	52.5	126.3	96.4	31.7	45.4		94.8	31.1	
Queue Delay	0.0	0.0	0.0	0.0	0.0	0.0	0.0	0.0		0.0	0.0	
Total Delay	108.3	75.9	49.1	52.5	126.3	96.4	31.7	45.4		94.8	31.1	
LOS	F	E	D	D	F	F	C	D		F	C	
Approach Delay		87.8			98.7			44.6			43.6	
Approach LOS		F			F			D			D	
Queue Length 50th (ft)	292	276	66	143	~380	~396	55	688		191	418	
Queue Length 95th (ft)	#519	#423	117	212	#596	#691	93	785		#367	505	
Internal Link Dist (ft)		1280			1041			978			979	
Turn Bay Length (ft)	225		300	150		450						
Base Capacity (vph)	286	379	542	359	308	437	293	1622		277	1776	
Starvation Cap Reductn	0	0	0	0	0	0	0	0		0	0	
Spillback Cap Reductn	0	0	0	0	0	0	0	0		0	0	
Storage Cap Reductn	0	0	0	0	0	0	0	0		0	0	
Reduced v/c Ratio	1.00	0.66	0.14	0.46	1.01	1.02	0.29	0.81		0.89	0.57	

Intersection Summary

Area Type: Other
 Cycle Length: 180
 Actuated Cycle Length: 180
 Offset: 88 (49%), Referenced to phase 2:NBT and 6:SBTL, Start of Green
 Natural Cycle: 90
 Control Type: Actuated-Coordinated
 Maximum v/c Ratio: 1.02
 Intersection Signal Delay: 62.5 Intersection LOS: E
 Intersection Capacity Utilization 95.5% ICU Level of Service F
 Analysis Period (min) 15
 ~ Volume exceeds capacity, queue is theoretically infinite.
 Queue shown is maximum after two cycles.
 # 95th percentile volume exceeds capacity, queue may be longer.
 Queue shown is maximum after two cycles.

Splits and Phases: 5: NC 86 (MLK Jr. Blvd) & Estes Drive Extension/Estes Drive

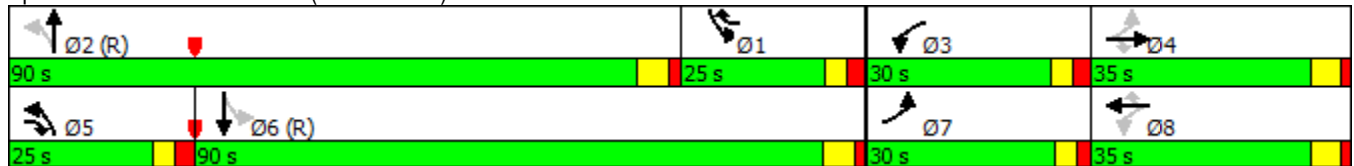

Lanes, Volumes, Timings
 1: Estes Drive Extension & Seawell School Road



* +	,*	,%	&,*	&,	%
*)	\$ 0	0	12	13	00
4 - . /	\$ 0	0	12	13	00
5 4 . /	\$	\$	\$	\$	\$
+ 5 .6/	7 6			6	7 6
) *) . /	2		3		3
) *					
*) . /	3		3		
* 8 9 4	9	9	9	9	9
4		903			903
4 ! 5	9\$3		9\$3		
59 4 . /	\$ 3\$		3 0 1	0 \$	321
4 ! 5	9\$3		9 0		
59 4 . /	\$ 3\$		1\$ \$ 0 1	0 \$	321
%) % 5		&			&
59 4 .% :%/					
* " 5 . /	3		3	3	
* "; . /	01		123	0 3	
. /	190		91	19	
! " 4	9\$	9\$	9\$	9\$	9\$
# - .6/	6	6	6	6	16 16
5<9 4 . /		3	0		\$ \$
5* .6/					
* + 4 . /		3	0		\$ \$
, ' " 5	&	&	&	&	& &
*)	*	%)	*	*	* %)
5 5 . /					
* " : . /					
" 5 . /	1		1	1	
# * *					
5 # 4	9\$0	9\$0	9	9	9\$0 9\$0
) 5 . /	3	\$	3		\$
#	!	!	=	&	& =
! 5!	2		3		1 2
! 5!		2			1
; !	2	2	3		1 2
!					
. /	9	9	9	9	9 9
. /	29	29	29	\$9	\$9 29
. /	39	39	39	39	1 9 39
.6/	39 6	39 6	39 6	39 6	1 9 6 39 6
> . /	9	9	9	39	39 9
7% 5 . /	9	9	9\$	9	9 9
* 5< . /	7 92	7 92	9	7 9	7 9 7 92
* . /	39	39	39	39	39 39
* 5 *)			* 5		*)
* 57*) : ? @			>		>
% 5	&	&	&		&
, + . /	9\$	9\$	9	9	91 391

Lanes, Volumes, Timings
 1: Estes Drive Extension & Seawell School Road

12/13/2017



Lane Group	SEL	SER	NEL	NET	SWT	SWR
Actuated g/C Ratio	0.23	0.23	0.58	0.58	0.31	0.64
v/c Ratio	0.51	0.56	0.52	0.66	0.51	0.10
Control Delay	24.6	26.4	9.8	12.1	19.6	3.8
Queue Delay	0.0	0.0	0.0	0.0	0.0	0.0
Total Delay	24.6	26.4	9.8	12.1	19.6	3.8
LOS	C	C	A	B	B	A
Approach Delay	25.5			11.4	15.6	
Approach LOS	C			B	B	
Queue Length 50th (ft)	58	57	42	131	75	10
Queue Length 95th (ft)	138	138	104	305	157	21
Internal Link Dist (ft)	782			565	745	
Turn Bay Length (ft)	400		250			75
Base Capacity (vph)	654	585	599	1809	1703	1196
Starvation Cap Reductn	0	0	0	0	0	0
Spillback Cap Reductn	0	0	0	0	0	0
Storage Cap Reductn	0	0	0	0	0	0
Reduced v/c Ratio	0.32	0.35	0.51	0.39	0.17	0.08

Intersection Summary

Area Type:	Other
Cycle Length:	100
Actuated Cycle Length:	55.9
Natural Cycle:	50
Control Type:	Actuated-Uncoordinated
Maximum v/c Ratio:	0.66
Intersection Signal Delay:	15.5
Intersection LOS:	B
Intersection Capacity Utilization:	52.8%
ICU Level of Service:	A
Analysis Period (min):	15

Splits and Phases: 1: Estes Drive Extension & Seawell School Road



Lanes, Volumes, Timings

5: NC 86 (MLK Jr. Blvd) & Estes Drive Extension/Estes Drive

12/13/2017



Lane Group	EBL	EBT	EBR	WBL	WBT	WBR	NBL	NBT	NBR	SBL	SBT	SBR
Lane Configurations												
Traffic Volume (vph)	316	369	85	148	148	254	38	418	117	330	1021	197
Future Volume (vph)	316	369	85	148	148	254	38	418	117	330	1021	197
Ideal Flow (vphpl)	1900	1900	1900	1900	1900	1900	1900	1900	1900	1900	1900	1900
Grade (%)		0%			1%			1%			-2%	
Storage Length (ft)	225		225	300		250	0		225	0		150
Storage Lanes	1		1	2		1	1		1	1		1
Taper Length (ft)	25			25			25			25		
Lane Util. Factor	1.00	1.00	1.00	0.97	1.00	1.00	1.00	0.95	1.00	1.00	0.95	1.00
Ped Bike Factor	1.00					0.99			0.96	0.99		
Frt			0.850			0.850			0.850			0.850
Flt Protected	0.950			0.950			0.950			0.950		
Satd. Flow (prot)	1770	1863	1583	3287	1783	1516	1678	3357	1502	1770	3540	1584
Flt Permitted	0.950			0.950			0.162			0.365		
Satd. Flow (perm)	1768	1863	1583	3287	1783	1496	286	3357	1444	675	3540	1584
Right Turn on Red			No			No			No			No
Satd. Flow (RTOR)												
Link Speed (mph)		35			35			35			35	
Link Distance (ft)		1360			1121			1058			1059	
Travel Time (s)		26.5			21.8			20.6			20.6	
Confl. Peds. (#/hr)	1					1			7	7		
Peak Hour Factor	0.93	0.93	0.93	0.93	0.93	0.93	0.93	0.93	0.93	0.93	0.93	0.93
Heavy Vehicles (%)	2%	2%	2%	6%	6%	6%	7%	7%	7%	3%	3%	3%
Adj. Flow (vph)	340	397	91	159	159	273	41	449	126	355	1098	212
Shared Lane Traffic (%)												
Lane Group Flow (vph)	340	397	91	159	159	273	41	449	126	355	1098	212
Enter Blocked Intersection	No	No	No	No	No	No	No	No	No	No	No	No
Lane Alignment	Left	Left	Right	Left	Left	Right	Left	Left	Right	Left	Left	Right
Median Width(ft)		24			24			12			12	
Link Offset(ft)		0			0			0			0	
Crosswalk Width(ft)		16			16			16			16	
Two way Left Turn Lane												
Headway Factor	1.00	1.00	1.00	1.01	1.01	1.01	1.01	1.01	1.01	0.99	0.99	0.99
Turning Speed (mph)	15		9	15		9	15		9	15		9
Turn Type	Prot	NA	pm+ov	Prot	NA	pm+ov	pm+pt	NA	pm+ov	pm+pt	NA	pm+ov
Protected Phases	7	4	5	3	8	1	5	2	3	1	6	7
Permitted Phases			4			8	2		2	6		6
Detector Phase	7	4	5	3	8	1	5	2	3	1	6	7
Switch Phase												
Minimum Initial (s)	7.0	7.0	7.0	7.0	7.0	7.0	7.0	12.0	7.0	7.0	12.0	7.0
Minimum Split (s)	14.0	14.0	15.0	15.0	14.0	15.0	15.0	35.0	15.0	15.0	19.0	14.0
Total Split (s)	45.0	54.0	15.0	17.0	26.0	34.0	15.0	45.0	17.0	34.0	64.0	45.0
Total Split (%)	30.0%	36.0%	10.0%	11.3%	17.3%	22.7%	10.0%	30.0%	11.3%	22.7%	42.7%	30.0%
Yellow Time (s)	5.0	5.0	5.0	5.0	5.0	5.0	5.0	5.0	5.0	5.0	5.0	5.0
All-Red Time (s)	2.0	2.0	2.0	2.0	2.0	2.0	2.0	2.0	2.0	2.0	2.0	2.0
Lost Time Adjust (s)	-2.0	-2.0	-2.0	-2.0	-2.0	-2.0	-2.0	-2.0	-2.0	-2.0	-2.0	-2.0
Total Lost Time (s)	5.0	5.0	5.0	5.0	5.0	5.0	5.0	5.0	5.0	5.0	5.0	5.0
Lead/Lag	Lag	Lead	Lead	Lag	Lead	Lead	Lead	Lag	Lag	Lead	Lag	Lag
Lead-Lag Optimize?	Yes	Yes	Yes	Yes	Yes	Yes	Yes	Yes	Yes	Yes	Yes	Yes

Lanes, Volumes, Timings
 5: NC 86 (MLK Jr. Blvd) & Estes Drive Extension/Estes Drive

12/13/2017



Lane Group	EBL	EBT	EBR	WBL	WBT	WBR	NBL	NBT	NBR	SBL	SBT	SBR
Recall Mode	None	None	None	None	None	None	None	C-Max	None	None	C-Max	None
Act Effct Green (s)	34.8	39.4	48.8	14.3	18.9	43.1	61.6	52.1	66.4	81.3	66.8	101.6
Actuated g/C Ratio	0.23	0.26	0.33	0.10	0.13	0.29	0.41	0.35	0.44	0.54	0.45	0.68
v/c Ratio	0.83	0.81	0.18	0.51	0.71	0.63	0.20	0.39	0.20	0.65	0.70	0.20
Control Delay	71.7	64.9	22.3	70.4	80.1	30.5	23.2	40.8	15.7	27.5	37.8	5.4
Queue Delay	0.0	0.0	0.0	0.0	0.0	0.0	0.0	0.0	0.0	0.0	0.0	0.0
Total Delay	71.7	64.9	22.3	70.4	80.1	30.5	23.2	40.8	15.7	27.5	37.8	5.4
LOS	E	E	C	E	F	C	C	D	B	C	D	A
Approach Delay	63.0			54.6			34.5			31.5		
Approach LOS	E			D			C			C		
Queue Length 50th (ft)	316	366	46	75	150	121	19	181	42	202	463	42
Queue Length 95th (ft)	423	453	73	119	231	147	43	254	82	298	584	63
Internal Link Dist (ft)	1280			1041			978			979		
Turn Bay Length (ft)	225		225	300		250			225			150
Base Capacity (vph)	472	608	521	318	249	482	211	1166	647	577	1576	1128
Starvation Cap Reductn	0	0	0	0	0	0	0	0	0	0	0	0
Spillback Cap Reductn	0	0	0	0	0	0	0	0	0	0	0	0
Storage Cap Reductn	0	0	0	0	0	0	0	0	0	0	0	0
Reduced v/c Ratio	0.72	0.65	0.17	0.50	0.64	0.57	0.19	0.39	0.19	0.62	0.70	0.19

Intersection Summary

Area Type:	Other
Cycle Length:	150
Actuated Cycle Length:	150
Offset:	0 (0%), Referenced to phase 2:NBTL and 6:SBTL, Start of Green
Natural Cycle:	90
Control Type:	Actuated-Coordinated
Maximum v/c Ratio:	0.83
Intersection Signal Delay:	42.7
Intersection LOS:	D
Intersection Capacity Utilization	83.6%
ICU Level of Service	E
Analysis Period (min)	15

Splits and Phases: 5: NC 86 (MLK Jr. Blvd) & Estes Drive Extension/Estes Drive

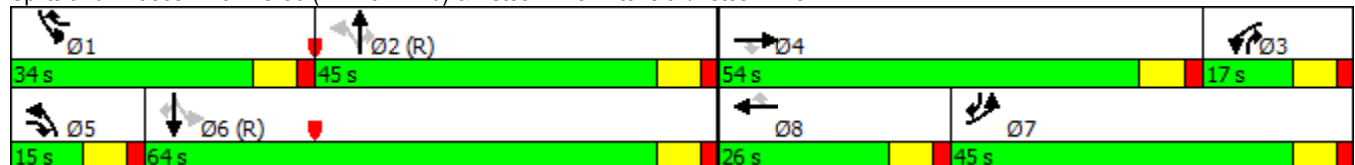

Lanes, Volumes, Timings
 1: Estes Drive Extension & Seawell School Road



	*)	+) +%	+) +	+	+	%
) (/0	\$		0	0	0\$
1 , - .	/0	\$		0	0	0\$
2 1 - .	\$	\$	\$	\$	\$	\$
* 2 -3.	43			3	43	
() (- .	5		0			0
()						
() (- .	0		0			
) 6 7 1	7	7	7	7	7	7
1		780				780
1 ! 2	7\$0		7\$0			
27 1 - .	\$	0\$	0	8/	8	0\$
1 ! 2	7\$0		7\$			
27 1 - .	\$	0\$		8/	8	0\$
%(% 2						
27 1 -% 9%						
) " 2 - .	0		0	0		
) " : - .	8/		/50	8 0		
- .	/78		7/	/7		
! " 1	7\$/	7\$/	7\$/	7\$/	7\$/	7\$/
# , -3.	3	3	3	3	3	3
;2<7 1 - .	/8	8	/	/		/
2) -3.						
) * 1 - .	/8	8	/	/		/
+ & " 2						
) ; ()	%())	%(
2 2 - .						
) " 9 - .						
" 2 - .	/		/	/		
#))						
2 # 1	7\$8	7\$8	7	7	7\$8	7\$8
(2 - .	0	\$	0			\$
#	!	!	=	;	;	=
! 2!	5		0		/	5
! 2!		5				/
: !	5	5	0		/	5
!						
- .	7	7	7	7	7	7
- .	57	57	57	\$7	\$7	57
- .	07	07	07	07	/7	07
-3.	07 3	07 3	07 3	07 3	/7 3	07 3
> - .	7	7	7	07	07	7
; 4% 2 - .	7	7	7\$	7	7	7
) ;2< - .	4 75	4 75	7	4 7	4 7	4 75
) - .	07	07	07	07	07	07
) 2) () 2) (
) 24) (9 ? @			>		>	
% 2						
; + * - .	87\$	87\$	7/	87\$	7	57/

& ' ! " # \$ % ! (

Lanes, Volumes, Timings
 1: Estes Drive Extension & Seawell School Road

12/13/2017



Lane Group	SEL	SER	NEL	NET	SWT	SWR
Actuated g/C Ratio	0.20	0.20	0.63	0.66	0.51	0.79
v/c Ratio	0.19	0.25	0.12	0.31	0.39	0.05
Control Delay	19.3	20.3	4.5	5.4	12.9	3.2
Queue Delay	0.0	0.0	0.0	0.0	0.0	0.0
Total Delay	19.3	20.3	4.5	5.4	12.9	3.2
LOS	B	C	A	A	B	A
Approach Delay	19.9			5.3	11.6	
Approach LOS	B			A	B	
Queue Length 50th (ft)	16	19	7	39	78	5
Queue Length 95th (ft)	50	58	20	85	164	15
Internal Link Dist (ft)	782			565	745	
Turn Bay Length (ft)	400		250			75
Base Capacity (vph)	861	770	695	1826	1845	1451
Starvation Cap Reductn	0	0	0	0	0	0
Spillback Cap Reductn	0	0	0	0	0	0
Storage Cap Reductn	0	0	0	0	0	0
Reduced v/c Ratio	0.08	0.11	0.11	0.20	0.20	0.04

Intersection Summary

Area Type:	Other
Cycle Length:	100
Actuated Cycle Length:	43.9
Natural Cycle:	50
Control Type:	Actuated-Uncoordinated
Maximum v/c Ratio:	0.39
Intersection Signal Delay:	10.1
Intersection LOS:	B
Intersection Capacity Utilization:	43.0%
ICU Level of Service:	A
Analysis Period (min):	15

Splits and Phases: 1: Estes Drive Extension & Seawell School Road



Lanes, Volumes, Timings

5: NC 86 (MLK Jr. Blvd) & Estes Drive Extension/Estes Drive

12/13/2017



Lane Group	EBL	EBT	EBR	WBL	WBT	WBR	NBL	NBT	NBR	SBL	SBT	SBR
Lane Configurations												
Traffic Volume (vph)	171	195	35	153	216	274	36	467	167	232	486	156
Future Volume (vph)	171	195	35	153	216	274	36	467	167	232	486	156
Ideal Flow (vphpl)	1900	1900	1900	1900	1900	1900	1900	1900	1900	1900	1900	1900
Grade (%)		0%			1%			1%			-2%	
Storage Length (ft)	225		225	300		250	0		225	0		150
Storage Lanes	1		1	2		1	1		1	1		1
Taper Length (ft)	25			25			25			25		
Lane Util. Factor	1.00	1.00	1.00	0.97	1.00	1.00	1.00	0.95	1.00	1.00	0.95	1.00
Ped Bike Factor									0.97	0.99		
Frt			0.850			0.850			0.850			0.850
Flt Protected	0.950			0.950			0.950			0.950		
Satd. Flow (prot)	1736	1827	1553	3350	1818	1545	1694	3389	1516	1753	3506	1568
Flt Permitted	0.950			0.950			0.335			0.475		
Satd. Flow (perm)	1736	1827	1553	3350	1818	1545	597	3389	1469	871	3506	1568
Right Turn on Red			No			No			No			No
Satd. Flow (RTOR)												
Link Speed (mph)		35			35			35				35
Link Distance (ft)		1360			1121			1058				1059
Travel Time (s)		26.5			21.8			20.6				20.6
Confl. Peds. (#/hr)									4	4		
Peak Hour Factor	0.96	0.96	0.96	0.96	0.96	0.96	0.96	0.96	0.96	0.96	0.96	0.96
Heavy Vehicles (%)	4%	4%	4%	4%	4%	4%	6%	6%	6%	4%	4%	4%
Adj. Flow (vph)	178	203	36	159	225	285	38	486	174	242	506	163
Shared Lane Traffic (%)												
Lane Group Flow (vph)	178	203	36	159	225	285	38	486	174	242	506	163
Enter Blocked Intersection	No	No	No	No	No	No	No	No	No	No	No	No
Lane Alignment	Left	Left	Right	Left	Left	Right	Left	Left	Right	Left	Left	Right
Median Width(ft)		24			24			12				12
Link Offset(ft)		0			0			0				0
Crosswalk Width(ft)		16			16			16				16
Two way Left Turn Lane												
Headway Factor	1.00	1.00	1.00	1.01	1.01	1.01	1.01	1.01	1.01	0.99	0.99	0.99
Turning Speed (mph)	15		9	15		9	15		9	15		9
Turn Type	Prot	NA	pm+ov	Prot	NA	pm+ov	pm+pt	NA	pm+ov	pm+pt	NA	pm+ov
Protected Phases	7	4	5	3	8	1	5	2	3	1	6	7
Permitted Phases			4			8	2		2	6		6
Detector Phase	7	4	5	3	8	1	5	2	3	1	6	7
Switch Phase												
Minimum Initial (s)	7.0	7.0	7.0	7.0	7.0	7.0	7.0	12.0	7.0	7.0	12.0	7.0
Minimum Split (s)	14.0	14.0	15.0	15.0	14.0	15.0	15.0	35.0	15.0	15.0	19.0	14.0
Total Split (s)	37.0	59.0	17.0	20.0	42.0	35.0	17.0	46.0	20.0	35.0	64.0	37.0
Total Split (%)	23.1%	36.9%	10.6%	12.5%	26.3%	21.9%	10.6%	28.8%	12.5%	21.9%	40.0%	23.1%
Yellow Time (s)	5.0	5.0	5.0	5.0	5.0	5.0	5.0	5.0	5.0	5.0	5.0	5.0
All-Red Time (s)	2.0	2.0	2.0	2.0	2.0	2.0	2.0	2.0	2.0	2.0	2.0	2.0
Lost Time Adjust (s)	-2.0	-2.0	-2.0	-2.0	-2.0	-2.0	-2.0	-2.0	-2.0	-2.0	-2.0	-2.0
Total Lost Time (s)	5.0	5.0	5.0	5.0	5.0	5.0	5.0	5.0	5.0	5.0	5.0	5.0
Lead/Lag	Lead	Lag	Lead	Lead	Lag	Lag	Lead	Lead	Lead	Lag	Lag	Lead
Lead-Lag Optimize?	Yes	Yes	Yes	Yes	Yes	Yes	Yes	Yes	Yes	Yes	Yes	Yes

Lanes, Volumes, Timings

5: NC 86 (MLK Jr. Blvd) & Estes Drive Extension/Estes Drive

12/13/2017



Lane Group	EBL	EBT	EBR	WBL	WBT	WBR	NBL	NBT	NBR	SBL	SBT	SBR
Recall Mode	None	None	None	None	None	None	None	C-Max	None	None	C-Max	None
Act Effct Green (s)	23.6	36.7	52.0	13.9	27.0	57.0	59.3	59.3	73.3	81.8	81.8	110.5
Actuated g/C Ratio	0.15	0.23	0.32	0.09	0.17	0.36	0.37	0.37	0.46	0.51	0.51	0.69
v/c Ratio	0.70	0.48	0.07	0.55	0.73	0.52	0.13	0.39	0.26	0.40	0.28	0.15
Control Delay	78.5	55.7	33.3	77.1	76.7	25.8	38.5	40.2	15.9	33.6	25.7	10.7
Queue Delay	0.0	0.0	0.0	0.0	0.0	0.0	0.0	0.0	0.0	0.0	0.0	0.0
Total Delay	78.5	55.7	33.3	77.1	76.7	25.8	38.5	40.2	15.9	33.6	25.7	10.7
LOS	E	E	C	E	E	C	D	D	B	C	C	B
Approach Delay		63.5			55.1			34.0			25.1	
Approach LOS		E			E			C			C	
Queue Length 50th (ft)	179	187	26	82	226	154	26	196	54	146	161	58
Queue Length 95th (ft)	254	240	47	123	307	166	61	287	113	258	251	110
Internal Link Dist (ft)		1280			1041			978			979	
Turn Bay Length (ft)	225		225	300		250			225			150
Base Capacity (vph)	347	616	522	314	420	550	304	1256	686	610	1792	1164
Starvation Cap Reductn	0	0	0	0	0	0	0	0	0	0	0	0
Spillback Cap Reductn	0	0	0	0	0	0	0	0	0	0	0	0
Storage Cap Reductn	0	0	0	0	0	0	0	0	0	0	0	0
Reduced v/c Ratio	0.51	0.33	0.07	0.51	0.54	0.52	0.13	0.39	0.25	0.40	0.28	0.14

Intersection Summary

Area Type: Other
 Cycle Length: 160
 Actuated Cycle Length: 160
 Offset: 104 (65%), Referenced to phase 2:NBTL and 6:SBTL, Start of Green
 Natural Cycle: 80
 Control Type: Actuated-Coordinated
 Maximum v/c Ratio: 0.73
 Intersection Signal Delay: 40.8
 Intersection LOS: D
 Intersection Capacity Utilization 73.7%
 ICU Level of Service D
 Analysis Period (min) 15

Splits and Phases: 5: NC 86 (MLK Jr. Blvd) & Estes Drive Extension/Estes Drive

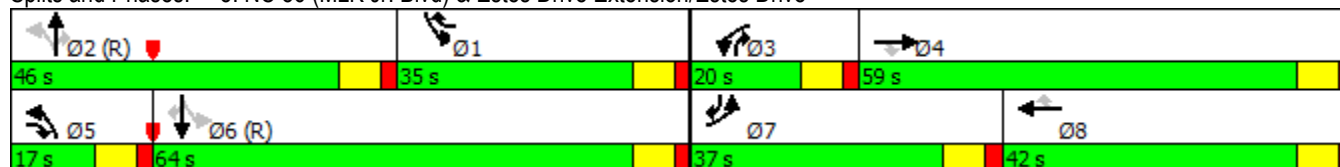

Lanes, Volumes, Timings
 1: Estes Drive Extension & Seawell School Road



	*)	+) +\$	%+)	%+	\$	
) (/ /	0	1#	012	22	
3 , - .	/ /	0	1#	012	22	
4 3 - .	# #	#	#	#	#	
* 4 -5.	6 5			5	6 5	
() (- .	1		2			2
()						
() (- .	2		2			
) 7 8 3	8	8	8	8	8	8
3		8/2				8/2
3 4	8#2		8#2			
48 3 - .	#0	0	2 /11	/#	0	
3 4	8#2		8 1			
48 3 - .	#0	0	/11	/#	0	
\$(\$ 4		%				%
48 3 -\$ 9\$.						
) ! 4 - .	2		2	2		
) !: - .	/0			012	/ 2	
- .	08/			80	08	
! 3	8#1	8#1	8#1	8#1	8#1	8#1
;4<8 3 - .	2	#	1 2	0/0	0 2	
4) -5.						
) * 3 - .	2	#	1 2	0/0	0 2	
+ & ! 4	%	%	%	%	%	%
) ; ()	\$()))	\$(
4 4 - .						
) ! 9 - .						
! 4 - .	0			0	0	
)						
4 " 3	8#/	8#/	8	8	8#/	8#/
(4 - .	2	#	2			#
"			=	%;	%;	=
4	1		2		0	1
4		1				0
:	1	1	2		0	1
- .	8	8	8	8	8	8
- .	18	18	18	#8	#8	18
- .	28	28	28	28	0 8	28
-5.	28 5	28 5	28 5	28 5	0 8 5	28 5
> - .	8	8	8	28	28	8
; 6\$ 4 - .	8	8	8#	8	8	8
) ;4< - .	6 8 1	6 8 1	8	6 8	6 8	6 8 1
) - .	28	28	28	28	28	28
) 4) () 4) (
) 46) (9 ? @			>		>	
\$ 4	%	%	%		%	
; + * - .	18	18	1/8	1/8	8/	2 8
; 4 (\$	8 #	8 #	800	800	810	8

Lanes, Volumes, Timings
 1: Estes Drive Extension & Seawell School Road

12/13/2017



Lane Group	SEL	SER	NEL	NET	SWT	SWR
v/c Ratio	0.33	0.62	0.46	0.36	0.79	0.14
Control Delay	31.7	39.5	9.2	6.5	24.3	3.0
Queue Delay	0.0	0.0	0.0	0.0	0.0	0.0
Total Delay	31.7	39.5	9.2	6.5	24.3	3.0
LOS	C	D	A	A	C	A
Approach Delay	36.6			7.3	20.2	
Approach LOS	D			A	C	
Queue Length 50th (ft)	44	79	24	73	249	18
Queue Length 95th (ft)	112	183	56	141	421	31
Internal Link Dist (ft)	782			565	745	
Turn Bay Length (ft)	400		250			75
Base Capacity (vph)	515	461	391	1664	1454	1314
Starvation Cap Reductn	0	0	0	0	0	0
Spillback Cap Reductn	0	0	0	0	0	0
Storage Cap Reductn	0	0	0	0	0	0
Reduced v/c Ratio	0.22	0.42	0.44	0.26	0.47	0.13

Intersection Summary

Area Type: Other
 Cycle Length: 100
 Actuated Cycle Length: 73.5
 Natural Cycle: 60
 Control Type: Actuated-Uncoordinated
 Maximum v/c Ratio: 0.79
 Intersection Signal Delay: 18.6
 Intersection Capacity Utilization 61.5%
 Analysis Period (min) 15
 Intersection LOS: B
 ICU Level of Service B

Splits and Phases: 1: Estes Drive Extension & Seawell School Road



Lanes, Volumes, Timings

5: NC 86 (MLK Jr. Blvd) & Estes Drive Extension/Estes Drive

12/13/2017

Lane Group	EBL	EBT	EBR	WBL	WBT	WBR	NBL	NBT	NBR	SBL	SBT	SBR
Lane Configurations												
Traffic Volume (vph)	284	249	79	173	309	444	87	1132	180	247	700	309
Future Volume (vph)	284	249	79	173	309	444	87	1132	180	247	700	309
Ideal Flow (vphpl)	1900	1900	1900	1900	1900	1900	1900	1900	1900	1900	1900	1900
Grade (%)		0%			1%			1%			-2%	
Storage Length (ft)	225		225	300		250	0		225	0		150
Storage Lanes	1		1	2		1	1		1	1		1
Taper Length (ft)	25			25			25			25		
Lane Util. Factor	1.00	1.00	1.00	0.97	1.00	1.00	1.00	0.95	1.00	1.00	0.95	1.00
Ped Bike Factor									0.96			
Fr _t			0.850			0.850			0.850			0.850
Fl _t Protected	0.950			0.950			0.950			0.950		
Satd. Flow (prot)	1770	1863	1583	3416	1853	1575	1761	3522	1575	1787	3575	1599
Fl _t Permitted	0.950			0.950			0.198			0.071		
Satd. Flow (perm)	1770	1863	1583	3416	1853	1575	367	3522	1519	134	3575	1599
Right Turn on Red			No			No			No			No
Satd. Flow (RTOR)												
Link Speed (mph)		35			35			35			35	
Link Distance (ft)		1360			1121			1058			1059	
Travel Time (s)		26.5			21.8			20.6			20.6	
Confl. Peds. (#/hr)									5	5		
Peak Hour Factor	0.95	0.95	0.95	0.95	0.95	0.95	0.95	0.95	0.95	0.95	0.95	0.95
Adj. Flow (vph)	299	262	83	182	325	467	92	1192	189	260	737	325
Shared Lane Traffic (%)												
Lane Group Flow (vph)	299	262	83	182	325	467	92	1192	189	260	737	325
Enter Blocked Intersection	No	No	No	No	No	No	No	No	No	No	No	No
Lane Alignment	Left	Left	Right	Left	Left	Right	Left	Left	Right	Left	Left	Right
Median Width(ft)		24			24			12			12	
Link Offset(ft)		0			0			0			0	
Crosswalk Width(ft)		16			16			16			16	
Two way Left Turn Lane												
Headway Factor	1.00	1.00	1.00	1.01	1.01	1.01	1.01	1.01	1.01	0.99	0.99	0.99
Turning Speed (mph)	15		9	15		9	15		9	15		9
Turn Type	Prot	NA	pm+ov	Prot	NA	pm+ov	pm+pt	NA	pm+ov	pm+pt	NA	pm+ov
Protected Phases	7	4	5	3	8	1	5	2	3	1	6	7
Permitted Phases			4			8	2		2	6		6
Detector Phase	7	4	5	3	8	1	5	2	3	1	6	7
Switch Phase												
Minimum Initial (s)	7.0	7.0	7.0	7.0	7.0	7.0	7.0	12.0	7.0	7.0	12.0	7.0
Minimum Split (s)	14.0	14.0	15.0	15.0	14.0	15.0	15.0	35.0	15.0	15.0	19.0	14.0
Total Split (s)	38.0	57.0	15.0	20.0	39.0	32.0	15.0	71.0	20.0	32.0	88.0	38.0
Total Split (%)	21.1%	31.7%	8.3%	11.1%	21.7%	17.8%	8.3%	39.4%	11.1%	17.8%	48.9%	21.1%
Yellow Time (s)	5.0	5.0	5.0	5.0	5.0	5.0	5.0	5.0	5.0	5.0	5.0	5.0
All-Red Time (s)	2.0	2.0	2.0	2.0	2.0	2.0	2.0	2.0	2.0	2.0	2.0	2.0
Lost Time Adjust (s)	-2.0	-2.0	-2.0	-2.0	-2.0	-2.0	-2.0	-2.0	-2.0	-2.0	-2.0	-2.0
Total Lost Time (s)	5.0	5.0	5.0	5.0	5.0	5.0	5.0	5.0	5.0	5.0	5.0	5.0
Lead/Lag	Lead	Lag	Lead	Lead	Lag	Lag	Lead	Lead	Lead	Lag	Lag	Lead
Lead-Lag Optimize?	Yes	Yes	Yes	Yes	Yes	Yes	Yes	Yes	Yes	Yes	Yes	Yes
Recall Mode	None	None	None	None	None	None	None	C-Max	None	None	C-Max	None

Lanes, Volumes, Timings

5: NC 86 (MLK Jr. Blvd) & Estes Drive Extension/Estes Drive

12/13/2017



Lane Group	EBL	EBT	EBR	WBL	WBT	WBR	NBL	NBT	NBR	SBL	SBT	SBR
Act Effect Green (s)	32.6	51.6	66.6	14.6	33.6	60.6	66.8	66.8	81.4	83.9	83.9	121.4
Actuated g/C Ratio	0.18	0.29	0.37	0.08	0.19	0.34	0.37	0.37	0.45	0.47	0.47	0.67
v/c Ratio	0.93	0.49	0.14	0.66	0.94	0.88	0.43	0.91	0.27	0.84	0.44	0.30
Control Delay	107.6	56.9	38.4	92.2	106.1	54.3	44.5	65.1	17.6	90.5	33.6	12.9
Queue Delay	0.0	0.0	0.0	0.0	0.0	0.0	0.0	0.0	0.0	0.0	0.0	0.0
Total Delay	107.6	56.9	38.4	92.2	106.1	54.3	44.5	65.1	17.6	90.5	33.6	12.9
LOS	F	E	D	F	F	D	D	E	B	F	C	B
Approach Delay		78.1			78.7			57.7				39.7
Approach LOS		E			E			E				D
Queue Length 50th (ft)	352	258	65	109	383	323	73	711	84	250	308	150
Queue Length 95th (ft)	#540	356	110	155	#580	#478	120	#824	122	#404	367	204
Internal Link Dist (ft)		1280			1041			978				979
Turn Bay Length (ft)	225		225	300		250			225			150
Base Capacity (vph)	324	538	585	284	350	530	214	1307	695	310	1665	1082
Starvation Cap Reductn	0	0	0	0	0	0	0	0	0	0	0	0
Spillback Cap Reductn	0	0	0	0	0	0	0	0	0	0	0	0
Storage Cap Reductn	0	0	0	0	0	0	0	0	0	0	0	0
Reduced v/c Ratio	0.92	0.49	0.14	0.64	0.93	0.88	0.43	0.91	0.27	0.84	0.44	0.30

Intersection Summary

Area Type: Other
 Cycle Length: 180
 Actuated Cycle Length: 180
 Offset: 88 (49%), Referenced to phase 2:NBT and 6:SBTL, Start of Green
 Natural Cycle: 100
 Control Type: Actuated-Coordinated
 Maximum v/c Ratio: 0.94
 Intersection Signal Delay: 59.9 Intersection LOS: E
 Intersection Capacity Utilization 93.6% ICU Level of Service F
 Analysis Period (min) 15
 # 95th percentile volume exceeds capacity, queue may be longer.
 Queue shown is maximum after two cycles.

Splits and Phases: 5: NC 86 (MLK Jr. Blvd) & Estes Drive Extension/Estes Drive

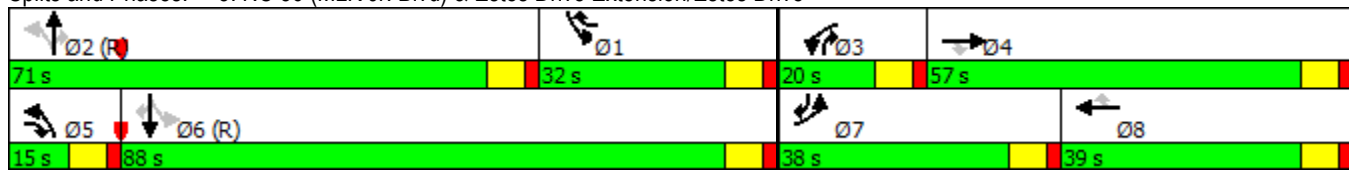

Lanes, Volumes, Timings
 5: NC 86 (MLK Jr. Blvd) & Estes Drive Extension/Estes Drive

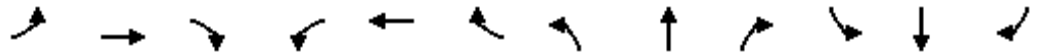

) * +) +' +'%) ' '% &) &' &'%) ' '%												
)												
4												
5 4 - .												
* 5 -6.												
) - .												
) - .												
) 8 9 4												
! 5' " 4												
4												
4 ! 5												
59 4 - .												
4 ! 5												
59 4 - .												
% % 5												
59 4 -% :%												
) " 5 - .												
) "; - .												
- .												
9 ! 5 9 -< .												
! " 4												
# , -6.												
5=9 4 - .												
5) -6.												
) * 4 - .												
+ ' " 5												
)												
5 5 - .												
) " : - .												
" 5 - .												
#))												
5 # 4												
5 - .												
#												
! 5!												
! 5!												
; !												
!												
- .												
- .												
- .												
-6.												
> - .												
7% 5 - .												
) 5= - .												
) - .												
) 5)												
) 57) : @ A												

&' & (! " # \$ % !

Lanes, Volumes, Timings

5: NC 86 (MLK Jr. Blvd) & Estes Drive Extension/Estes Drive

12/21/2017



Lane Group	EBL	EBT	EBR	WBL	WBT	WBR	NBL	NBT	NBR	SBL	SBT	SBR
Recall Mode	None	None	None	None	None	None	None	C-Max	None	None	C-Max	None
Act Effct Green (s)	29.4	38.5	48.5	13.3	22.4	45.9	64.6	54.6	67.9	83.2	68.2	97.6
Actuated g/C Ratio	0.20	0.26	0.32	0.09	0.15	0.31	0.43	0.36	0.45	0.55	0.45	0.65
v/c Ratio	0.51	0.83	0.19	0.55	0.68	0.59	0.38	0.37	0.19	0.64	0.68	0.24
Control Delay	56.6	68.0	23.3	72.8	72.6	28.1	24.7	38.3	14.9	25.7	36.2	6.9
Queue Delay	0.0	0.0	0.0	0.0	0.0	0.0	0.0	0.0	0.0	0.0	0.0	0.0
Total Delay	56.6	68.0	23.3	72.8	72.6	28.1	24.7	38.3	14.9	25.7	36.2	6.9
LOS	E	E	C	E	E	C	C	D	B	C	D	A
Approach Delay		58.2			52.8			32.1			29.8	
Approach LOS		E			D			C			C	
Queue Length 50th (ft)	153	369	50	77	169	128	38	175	42	194	459	53
Queue Length 95th (ft)	210	475	80	118	241	160	71	244	76	286	564	99
Internal Link Dist (ft)		1280			1041			978			979	
Turn Bay Length (ft)	300		225	300		250			225			150
Base Capacity (vph)	673	558	514	300	404	506	219	1222	663	584	1609	1031
Starvation Cap Reductn	0	0	0	0	0	0	0	0	0	0	0	0
Spillback Cap Reductn	0	0	0	0	0	0	0	0	0	0	0	0
Storage Cap Reductn	0	0	0	0	0	0	0	0	0	0	0	0
Reduced v/c Ratio	0.51	0.72	0.19	0.53	0.45	0.54	0.37	0.37	0.19	0.61	0.68	0.24

Intersection Summary

Area Type:	Other
Cycle Length:	150
Actuated Cycle Length:	150
Offset:	0 (0%), Referenced to phase 2:NBTL and 6:SBTL, Start of Green
Natural Cycle:	90
Control Type:	Actuated-Coordinated
Maximum v/c Ratio:	0.83
Intersection Signal Delay:	40.1
Intersection LOS:	D
Intersection Capacity Utilization	83.6%
ICU Level of Service	E
Analysis Period (min)	15

Splits and Phases: 5: NC 86 (MLK Jr. Blvd) & Estes Drive Extension/Estes Drive

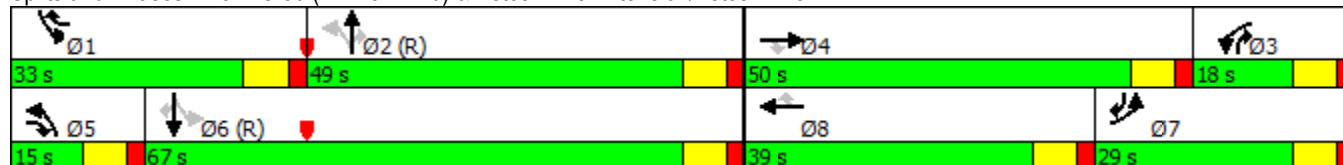

Lanes, Volumes, Timings
 5: NC 86 (MLK Jr. Blvd) & Estes Drive Extension/Estes Drive

	↖	→	↘	↙	←	↖	↙	↑	↘	↓	↙	
()	*&	*&	*&%	&(&	&%	&(&	&%	&(&	&%
(↖	↖	↖	↖	↖	↖	↖	↖	↖	↖	↖	↖
+ , -	\$.	/	01	\$	2	/	2/	/	1	2./	.
3 + , -	\$.	/	01	\$	2	/	2/	/	1	2./	.
4 3 , -	\$	\$	\$	\$	\$	\$	\$	\$	\$	\$	\$	\$
) 4 ,5-		5			5			5			6 5	
(, -	1		0	1		0			0			0
(
(, -	0			0				0			0	
(7 8 3	8\$	8	8	8\$	8	8	8	8\$0	8	8	8\$0	8
! 4 & " 3								8\$		8\$		
3			8.0			8.0		8.0			8.0	
3 ! 4	8\$0			8\$0			8\$0			8\$0		
48 3 , -	11/	.	001	110	..	020	/2	11.\$	0/	01	10/	0/.
3 ! 4	8\$0			8\$0			81/			82 0		
48 3 , -	11/	.	001	110	..	020	/2	11.\$	2/\$.	10/	0/.
%	% 4											
48 3 , % 9%-												
(" 4 , -			10			10			10			10
(" : , -			1/						0.			0\$
, -			/80			8.			8/			8/
8 ! 4 8 ; , -									2		2	
! " 3	8\$/	8\$/	8\$/	8\$/	8\$/	8\$/	8\$/	8\$/	8\$/	8\$/	8\$/	8\$/
# + ,5-	25	25	25	25	25	25	/5	/5	/5	25	25	25
< 4 = 8 3 , -			/1	0\$	1\$.0	/0	2./	2	2	0/	.0
4 (,5-												
() 3 , -			/1	0\$	1\$.0	/0	2./	2	2	0/	.0
* & " 4												
(<	(%	((%	((%	((%	
4 4 , -			2			2						
(" 9 , -												
" 4 , -			/			/			/			/
# ((>									
4 # 3	8	8	8	8	8	8	8	8	8	8\$	8\$	8\$
4 , -	0			\$	0		\$	0		\$	0	\$
#	!	<	?	!	<	?	?	<	?	?	<	?
! 4!			2	0	1	.		0		1		/
! 4!				2		.					/	/
: !			2	0	1	.		0		1		/
!												
, -	8	8	8	8	8	8	8	8	8	8	8	8
, -	28	28	08	08	28	08	08	108	08	08	\$8	28
, -	/8	08	8	8	28	18	8	08	8	18	/8	/8
,5-	/815	18\$5	805	18.5	\$825	.8.5	805	108/5	18.5	.8.5	28\$5	/815
>	08	08	08	08	08	08	08	08	08	08	08	08
< 6% 4 , -	8	8	8	8	8	8	8	8	8	8	8	8
(< 4 = , -	6 8	6 8	6 8	6 8	6 8	6 8	6 8	6 8	6 8	6 8	6 8	6 8
(, -	08	08	08	08	08	08	08	08	08	08	08	08
(4 ((4	(4	(4	(4	(4	(4	(4	(4	(4	(4	(4	(4
(46(9 @ A	>	>	>	>	>	>	>	>	>	>	>	>

& ' ! # \$ % !

Lanes, Volumes, Timings

5: NC 86 (MLK Jr. Blvd) & Estes Drive Extension/Estes Drive

12/21/2017



Lane Group	EBL	EBT	EBR	WBL	WBT	WBR	NBL	NBT	NBR	SBL	SBT	SBR
Recall Mode	None	None	None	None	None	None	None	C-Max	None	None	C-Max	None
Act Effct Green (s)	16.8	30.5	47.0	14.6	28.4	53.4	69.8	69.8	84.5	83.4	83.4	105.2
Actuated g/C Ratio	0.10	0.19	0.29	0.09	0.18	0.33	0.44	0.44	0.53	0.52	0.52	0.66
v/c Ratio	0.57	0.62	0.14	0.52	0.74	0.55	0.18	0.33	0.22	0.41	0.28	0.18
Control Delay	74.2	66.6	39.6	75.3	75.9	30.8	30.7	31.9	11.8	31.4	23.6	12.4
Queue Delay	0.0	0.0	0.0	0.0	0.0	0.0	0.0	0.0	0.0	0.0	0.0	0.0
Total Delay	74.2	66.6	39.6	75.3	75.9	30.8	30.7	31.9	11.8	31.4	23.6	12.4
LOS	E	E	D	E	E	C	C	C	B	C	C	B
Approach Delay		66.2			57.0			27.0			23.4	
Approach LOS		E			E			C			C	
Queue Length 50th (ft)	104	212	49	82	240	179	40	174	47	137	151	71
Queue Length 95th (ft)	144	282	80	121	322	212	83	252	92	240	234	132
Internal Link Dist (ft)		1280			1041			978			979	
Turn Bay Length (ft)	300		225	300		250			225			150
Base Capacity (vph)	441	525	490	355	477	515	379	1479	801	591	1827	1072
Starvation Cap Reductn	0	0	0	0	0	0	0	0	0	0	0	0
Spillback Cap Reductn	0	0	0	0	0	0	0	0	0	0	0	0
Storage Cap Reductn	0	0	0	0	0	0	0	0	0	0	0	0
Reduced v/c Ratio	0.45	0.41	0.13	0.45	0.50	0.55	0.17	0.33	0.22	0.41	0.28	0.17

Intersection Summary

Area Type:	Other
Cycle Length:	160
Actuated Cycle Length:	160
Offset:	104 (65%), Referenced to phase 2:NBTL and 6:SBTL, Start of Green
Natural Cycle:	80
Control Type:	Actuated-Coordinated
Maximum v/c Ratio:	0.74
Intersection Signal Delay:	39.7
Intersection LOS:	D
Intersection Capacity Utilization:	70.7%
ICU Level of Service:	C
Analysis Period (min):	15

Splits and Phases: 5: NC 86 (MLK Jr. Blvd) & Estes Drive Extension/Estes Drive

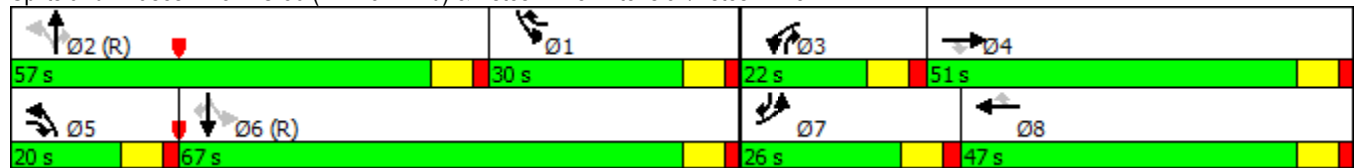

Lanes, Volumes, Timings
 5: NC 86 (MLK Jr. Blvd) & Estes Drive Extension/Estes Drive

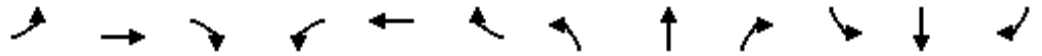

()	*&(*&	*&\$	&(&	&\$	%&(%&	%&\$	&(&	&\$
(↑↑	↑	↑	↑↑	↑	↑	↑	↑↑	↑	↑↑	↑	↑↑
+ , -	.	/	.	.0	///	#1	.	1	/	.	#	
2 + , -	.	/	.	.0	///	#1	.	1	/	.	#	
3 2 , -	#	#	#	#	#	#	#	#	#	#	#	#
) 3 ,4-		4		4		4		4		5	4	
(, -	0		0	.		0		0		0		0
(0		0			0		0		0		0
(6 72	7#	7	7	7#	7	7	7	7#0	7	7	7#0	7
3 &! 2										7#8		
2			710			710				710		710
2 3	7#0			7#0				7#0			7#0	
372 , -	./.	18.	01.	./8	10.	00	8	.0	00	1	.00	0##
2 3	7#0			7#0				7			7#0	
372 , -	./.	18.	01.	./8	10.	00	/	.0	0#	#	.00	0##
\$ \$3			%			%		%		%		%
372 , \$9\$-												
(! 3 , -		.0		.0		.0		.0		.0		.0
(!: , -		.8						01				0#
, -		870		71		78						78
7 37 ; -								0		0		
! 2	7#0	7#0	7#0	7#0	7#0	7#0	7#0	7#0	7#0	7#0	7#0	7#0
<3=72 , -	..#	18	.	1	..	/8	.	#	1#	8	.	..8
3(,4-												
() 2 , -	..#	18	.	1	..	/8	.	#	1#	8	.	..8
* &!3	%	%	%	%	%	%	%	%	%	%	%	%
(<	((\$	((\$	((\$	((\$
3 3 , -		/		/								
(!9 , -												
! 3 , -		8		8		8		8		8		8
"((>										
3 "2	7	7	7	7	7	7	7	7	7	7	7##	7##
3 , -	0		#	0		#	0		#	0		#
"	%<	?		%<	?	?	%<	?	?	%<	?	
3	/	0	.	1		0		.		8		8
3	/			1		1				8		8
:	/	0	.	1		0		.		8		8
, -	7	7	7	7	7	7	7	7	7	7	7	7
, -	/7	/7	07	07	/7	07	07	.07	07	07	#7	/7
, -	87	07	07	7	//7	.07	07	07	7	.07	#07	87
,4-	/7/4	714	17.4	74	/7/4	#7/4	17.4	/74	74	#7/4	0714	/7/4
>	07	07	07	07	07	07	07	07	07	07	07	07
< 5\$3 , -	7	7	7	7	7	7	7	7	7	7	7	7
(<3= , -	57	57	57	57	57	57	57	57	57	57	57	57
(, -	07	07	07	07	07	07	07	07	07	07	07	07
(3((3	(3	(3	(3	(3	(3
(35(9 @ A	>	>	>	>	>	>	>	>	>	>	>	>
\$ 3	%	%	%	%	%	%	5 B	%	%	5 B	%	

Lanes, Volumes, Timings

5: NC 86 (MLK Jr. Blvd) & Estes Drive Extension/Estes Drive

12/21/2017



Lane Group	EBL	EBT	EBR	WBL	WBT	WBR	NBL	NBT	NBR	SBL	SBT	SBR
Act Effect Green (s)	20.8	42.9	58.4	14.6	36.7	66.7	72.5	72.5	87.1	92.0	92.0	117.8
Actuated g/C Ratio	0.12	0.24	0.32	0.08	0.20	0.37	0.40	0.40	0.48	0.51	0.51	0.65
v/c Ratio	0.85	0.65	0.26	0.66	0.88	0.80	0.42	0.84	0.26	0.72	0.40	0.32
Control Delay	98.0	68.8	45.9	92.2	93.3	45.5	40.4	55.5	15.2	73.5	28.3	14.9
Queue Delay	0.0	0.0	0.0	0.0	0.0	0.0	0.0	0.0	0.0	0.0	0.0	0.0
Total Delay	98.0	68.8	45.9	92.2	93.3	45.5	40.4	55.5	15.2	73.5	28.3	14.9
LOS	F	E	D	F	F	D	D	E	B	E	C	B
Approach Delay		77.9			70.3			49.4				33.7
Approach LOS		E			E			D				C
Queue Length 50th (ft)	206	303	113	109	379	341	79	685	73	217	285	171
Queue Length 95th (ft)	#285	412	175	155	#534	451	127	784	107	329	338	232
Internal Link Dist (ft)		1280			1041			978				979
Turn Bay Length (ft)	225		225	300		250			225			150
Base Capacity (vph)	400	465	513	284	401	583	248	1418	742	359	1827	1048
Starvation Cap Reductn	0	0	0	0	0	0	0	0	0	0	0	0
Spillback Cap Reductn	0	0	0	0	0	0	0	0	0	0	0	0
Storage Cap Reductn	0	0	0	0	0	0	0	0	0	0	0	0
Reduced v/c Ratio	0.85	0.62	0.26	0.64	0.83	0.80	0.42	0.84	0.25	0.72	0.40	0.32

Intersection Summary

Area Type: Other
 Cycle Length: 180
 Actuated Cycle Length: 180
 Offset: 88 (49%), Referenced to phase 2:NBT and 6:SBTL, Start of Green
 Natural Cycle: 90
 Control Type: Actuated-Coordinated
 Maximum v/c Ratio: 0.88
 Intersection Signal Delay: 54.0 Intersection LOS: D
 Intersection Capacity Utilization 87.4% ICU Level of Service E
 Analysis Period (min) 15
 # 95th percentile volume exceeds capacity, queue may be longer.
 Queue shown is maximum after two cycles.

Splits and Phases: 5: NC 86 (MLK Jr. Blvd) & Estes Drive Extension/Estes Drive

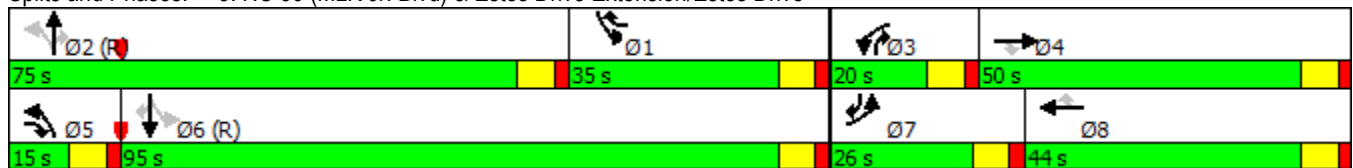

Lanes, Volumes, Timings
 1: Estes Drive Extension & Seawell School Road



*	+	,	*	,%	&,*	&,	%
*)						
-	.	/	\$0	0	0	12\$	11 0\$
3	-	.	\$0	0	0	12\$	11 0\$
4	3	.	\$	\$	\$	\$	\$
+	4	.5/	65			5	65
)	*)	.	/	2	7	7
)	*						
*)	.	/	7	7		
*	8	93	9	9	9	9	9
3			907				907
3	!	4	9\$7		9\$7		
49	3	.	/	\$	7\$	7 01	0\$ 721
3	!	4	9\$7		90		
49	3	.	/	\$	7\$	1\$ \$ 01	0\$ 721
%)		% 4			&		&
49	3	.% :%/					
*	"	4	.	/	7	7	7
*	;	.	/	01		127	07
		.	/	190		91	19
!	"	3	9\$	9\$	9\$	9\$	9\$ 9\$
#	-	.5/	5	5	5	5	15 15
4<	9	3	.	/	0	7	0 \$ \$0
4*		.5/					
*	+	3	.	/	0	7	0 \$ \$0
,	'	"4	&	&	&	&	& &
*)		*	%)	*	*	* %)
4	4	.	/				
*	"	.	/				
"	4	.	/	1		1	1
#	*	*					
4	#	3	9\$0	9\$0	9	9	9\$0 9\$0
)	4	.	/	7	\$	7	\$
#			!	!	=	&	& =
!	4!		2		7		1 2
!	4!			2			1
;	!		2	2	7		1 2
!							
.	.	/	9	9	9	9	9 9
.	.	/	29	29	29	\$9	\$9 29
.	.	/	79	79	79	79	19 79
.5/			795	795	795	795	195 795
>	.	/	9	9	9	79	79 9
6% 4	.	/	9	9	9\$	9	9 9
*	4<	.	/	6 92	6 92	9	6 9 6 9 6 92
*	.	/	79	79	79	79	79 79
* 4*)					* 4		*)
* 46*)	:	? @			>		>
% 4			&	&	&		&
,	+	.	/	9\$	9\$	90	90 9 79

Lanes, Volumes, Timings
 1: Estes Drive Extension & Seawell School Road

12/13/2017



Lane Group	SEL	SER	NEL	NET	SWT	SWR
Actuated g/C Ratio	0.23	0.23	0.59	0.59	0.32	0.64
v/c Ratio	0.53	0.56	0.52	0.67	0.51	0.10
Control Delay	25.1	26.6	9.7	12.2	19.5	3.8
Queue Delay	0.0	0.0	0.0	0.0	0.0	0.0
Total Delay	25.1	26.6	9.7	12.2	19.5	3.8
LOS	C	C	A	B	B	A
Approach Delay	25.8			11.4	15.5	
Approach LOS	C			B	B	
Queue Length 50th (ft)	60	57	42	132	76	10
Queue Length 95th (ft)	144	140	104	308	157	21
Internal Link Dist (ft)	782			565	745	
Turn Bay Length (ft)	400		250			75
Base Capacity (vph)	653	584	599	1808	1699	1198
Starvation Cap Reductn	0	0	0	0	0	0
Spillback Cap Reductn	0	0	0	0	0	0
Storage Cap Reductn	0	0	0	0	0	0
Reduced v/c Ratio	0.33	0.35	0.51	0.39	0.17	0.08

Intersection Summary

Area Type:	Other
Cycle Length:	100
Actuated Cycle Length:	56
Natural Cycle:	50
Control Type:	Actuated-Uncoordinated
Maximum v/c Ratio:	0.67
Intersection Signal Delay:	15.6
Intersection LOS:	B
Intersection Capacity Utilization:	53.5%
ICU Level of Service:	A
Analysis Period (min):	15



























Splits and Phases: 1: Estes Drive Extension & Seawell School Road



Lanes, Volumes, Timings

5: NC 86 (MLK Jr. Blvd) & Estes Drive Extension/Estes Drive

12/13/2017

												
Lane Group	EBL	EBT	EBR	WBL	WBT	WBR	NBL	NBT	NBR	SBL	SBT	SBR
Lane Configurations				 				 			 	
Traffic Volume (vph)	320	371	90	148	167	254	76	418	117	330	1021	229
Future Volume (vph)	320	371	90	148	167	254	76	418	117	330	1021	229
Ideal Flow (vphpl)	1900	1900	1900	1900	1900	1900	1900	1900	1900	1900	1900	1900
Grade (%)		0%			1%			1%			-2%	
Storage Length (ft)	225		225	300		250	0		225	0		150
Storage Lanes	1		1	2		1	1		1	1		1
Taper Length (ft)	25			25			25			25		
Lane Util. Factor	1.00	1.00	1.00	0.97	1.00	1.00	1.00	0.95	1.00	1.00	0.95	1.00
Ped Bike Factor	1.00					0.99			0.96	0.99		
Frt			0.850			0.850			0.850			0.850
Flt Protected	0.950			0.950			0.950			0.950		
Satd. Flow (prot)	1770	1863	1583	3287	1783	1516	1678	3357	1502	1770	3540	1584
Flt Permitted	0.950			0.950			0.154			0.361		
Satd. Flow (perm)	1768	1863	1583	3287	1783	1496	272	3357	1444	668	3540	1584
Right Turn on Red			No			No			No			No
Satd. Flow (RTOR)												
Link Speed (mph)		35			35			35			35	
Link Distance (ft)		1360			1121			1058			1059	
Travel Time (s)		26.5			21.8			20.6			20.6	
Confl. Peds. (#/hr)	1					1			7	7		
Peak Hour Factor	0.93	0.93	0.93	0.93	0.93	0.93	0.93	0.93	0.93	0.93	0.93	0.93
Heavy Vehicles (%)	2%	2%	2%	6%	6%	6%	7%	7%	7%	3%	3%	3%
Adj. Flow (vph)	344	399	97	159	180	273	82	449	126	355	1098	246
Shared Lane Traffic (%)												
Lane Group Flow (vph)	344	399	97	159	180	273	82	449	126	355	1098	246
Enter Blocked Intersection	No	No	No	No	No	No	No	No	No	No	No	No
Lane Alignment	Left	Left	Right	Left	Left	Right	Left	Left	Right	Left	Left	Right
Median Width(ft)		24			24			12			12	
Link Offset(ft)		0			0			0			0	
Crosswalk Width(ft)		16			16			16			16	
Two way Left Turn Lane												
Headway Factor	1.00	1.00	1.00	1.01	1.01	1.01	1.01	1.01	1.01	0.99	0.99	0.99
Turning Speed (mph)	15		9	15		9	15		9	15		9
Turn Type	Prot	NA	pm+ov	Prot	NA	pm+ov	pm+pt	NA	pm+ov	pm+pt	NA	pm+ov
Protected Phases	7	4	5	3	8	1	5	2	3	1	6	7
Permitted Phases			4			8	2		2	6		6
Detector Phase	7	4	5	3	8	1	5	2	3	1	6	7
Switch Phase												
Minimum Initial (s)	7.0	7.0	7.0	7.0	7.0	7.0	7.0	12.0	7.0	7.0	12.0	7.0
Minimum Split (s)	14.0	14.0	15.0	15.0	14.0	15.0	15.0	35.0	15.0	15.0	19.0	14.0
Total Split (s)	45.0	54.0	15.0	17.0	26.0	34.0	15.0	45.0	17.0	34.0	64.0	45.0
Total Split (%)	30.0%	36.0%	10.0%	11.3%	17.3%	22.7%	10.0%	30.0%	11.3%	22.7%	42.7%	30.0%
Yellow Time (s)	5.0	5.0	5.0	5.0	5.0	5.0	5.0	5.0	5.0	5.0	5.0	5.0
All-Red Time (s)	2.0	2.0	2.0	2.0	2.0	2.0	2.0	2.0	2.0	2.0	2.0	2.0
Lost Time Adjust (s)	-2.0	-2.0	-2.0	-2.0	-2.0	-2.0	-2.0	-2.0	-2.0	-2.0	-2.0	-2.0
Total Lost Time (s)	5.0	5.0	5.0	5.0	5.0	5.0	5.0	5.0	5.0	5.0	5.0	5.0
Lead/Lag	Lag	Lead	Lead	Lag	Lead	Lead	Lead	Lag	Lag	Lead	Lag	Lag
Lead-Lag Optimize?	Yes	Yes	Yes	Yes	Yes	Yes	Yes	Yes	Yes	Yes	Yes	Yes

Lanes, Volumes, Timings

5: NC 86 (MLK Jr. Blvd) & Estes Drive Extension/Estes Drive

12/13/2017



Lane Group	EBL	EBT	EBR	WBL	WBT	WBR	NBL	NBT	NBR	SBL	SBT	SBR
Recall Mode	None	None	None	None	None	None	None	C-Max	None	None	C-Max	None
Act Effect Green (s)	35.1	39.5	49.6	15.2	19.7	44.0	61.0	51.0	66.2	80.2	65.2	100.3
Actuated g/C Ratio	0.23	0.26	0.33	0.10	0.13	0.29	0.41	0.34	0.44	0.53	0.43	0.67
v/c Ratio	0.83	0.81	0.19	0.48	0.77	0.62	0.40	0.39	0.20	0.66	0.71	0.23
Control Delay	71.7	64.8	21.9	68.9	84.4	29.6	27.4	41.5	15.8	28.2	39.2	5.8
Queue Delay	0.0	0.0	0.0	0.0	0.0	0.0	0.0	0.0	0.0	0.0	0.0	0.0
Total Delay	71.7	64.8	21.9	68.9	84.4	29.6	27.4	41.5	15.8	28.2	39.2	5.8
LOS	E	E	C	E	F	C	C	D	B	C	D	A
Approach Delay		62.7			55.9			34.8			32.1	
Approach LOS		E			E			C			C	
Queue Length 50th (ft)	320	368	47	75	171	118	40	183	42	205	480	51
Queue Length 95th (ft)	428	456	77	119	#272	147	74	254	82	298	584	74
Internal Link Dist (ft)		1280			1041			978			979	
Turn Bay Length (ft)	225		225	300		250			225			150
Base Capacity (vph)	472	608	525	333	249	489	207	1140	643	570	1539	1111
Starvation Cap Reductn	0	0	0	0	0	0	0	0	0	0	0	0
Spillback Cap Reductn	0	0	0	0	0	0	0	0	0	0	0	0
Storage Cap Reductn	0	0	0	0	0	0	0	0	0	0	0	0
Reduced v/c Ratio	0.73	0.66	0.18	0.48	0.72	0.56	0.40	0.39	0.20	0.62	0.71	0.22

Intersection Summary

Area Type: Other
 Cycle Length: 150
 Actuated Cycle Length: 150
 Offset: 0 (0%), Referenced to phase 2:NBTL and 6:SBTL, Start of Green
 Natural Cycle: 90
 Control Type: Actuated-Coordinated
 Maximum v/c Ratio: 0.83
 Intersection Signal Delay: 43.1
 Intersection LOS: D
 Intersection Capacity Utilization 84.8%
 ICU Level of Service E
 Analysis Period (min) 15
 # 95th percentile volume exceeds capacity, queue may be longer.
 Queue shown is maximum after two cycles.

Splits and Phases: 5: NC 86 (MLK Jr. Blvd) & Estes Drive Extension/Estes Drive

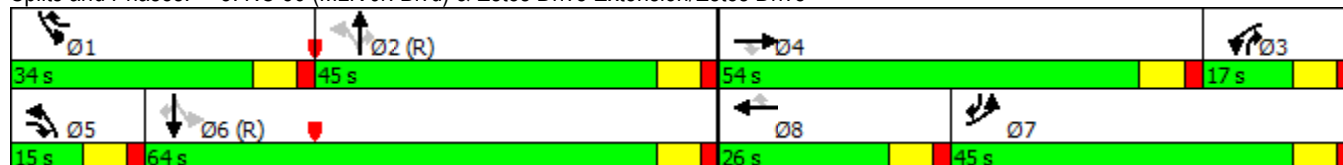

Lanes, Volumes, Timings
 1: Estes Drive Extension & Seawell School Road



	*)	+) +%	+) +	+	%
) (↑	↑	↑	↑	↑
, - .	/\$	\$		0/	/ /
1 , - .	/\$	\$		0/	/ /
2 1 - .	\$	\$	\$	\$	\$
* 2 -3.	43			3	43
() (- .	5		0		0
()					
() (- .	0		0		
) 6 7 1	7	7	7	7	7
1		780			780
1 ! 2	7\$0		7\$0		
27 1 - .	\$	0\$	0	8/	8 0\$
1 ! 2	7\$0		7 8		
27 1 - .	\$	0\$		8/	8 0\$
%(% 2					
27 1 -% 9%.					
) " 2 - .	0		0	0	
) " : - .	8/		/50	8 0	
- .	/78		7/	/7	
! " 1	7\$/	7\$/	7\$/	7\$/	7\$/ 7\$/
# , -3.	3	3	3	3	3 3
;2<7 1 - .		8	/	/	//
2) -3.					
) * 1 - .	8	/	/	//	
+ & " 2					
) ; ()	%())	%(
2 2 - .					
) " 9 - .					
" 2 - .	/		/	/	
#))					
2 # 1	7\$8	7\$8	7	7	7\$8 7\$8
(2 - .	0	\$	0		\$
#	!	!	=	;	;
! 2!	5		0	/	5
! 2!		5		/	
: !	5	5	0	/	5
!					
- .	7	7	7	7	7 7
- .	57	57	57	\$7	\$7 57
- .	07	07	07	07	/7 07
-3.	07 3	07 3	07 3	07 3	/7 3 07 3
> - .	7	7	7	07	07 7
; 4% 2 - .	7	7	7\$	7	7 7
) ;2< - .	4 75	4 75	7	4 7	4 7 4 75
) - .	07	07	07	07	07 07
) 2) () 2) (
) 24) (9 ? @			>		>
% 2					
; + * - .	87\$	87\$	7	\$7	7 57

& ' ! " # \$ % ! (

Lanes, Volumes, Timings
 1: Estes Drive Extension & Seawell School Road

12/13/2017



Lane Group	SEL	SER	NEL	NET	SWT	SWR
Actuated g/C Ratio	0.20	0.20	0.63	0.66	0.51	0.79
v/c Ratio	0.20	0.25	0.12	0.31	0.40	0.05
Control Delay	19.5	20.4	4.5	5.4	13.0	3.2
Queue Delay	0.0	0.0	0.0	0.0	0.0	0.0
Total Delay	19.5	20.4	4.5	5.4	13.0	3.2
LOS	B	C	A	A	B	A
Approach Delay	20.0			5.3	11.5	
Approach LOS	B			A	B	
Queue Length 50th (ft)	17	19	7	40	80	5
Queue Length 95th (ft)	53	59	20	85	166	16
Internal Link Dist (ft)	782			565	745	
Turn Bay Length (ft)	400		250			75
Base Capacity (vph)	858	768	693	1826	1844	1450
Starvation Cap Reductn	0	0	0	0	0	0
Spillback Cap Reductn	0	0	0	0	0	0
Storage Cap Reductn	0	0	0	0	0	0
Reduced v/c Ratio	0.08	0.11	0.11	0.20	0.20	0.05

Intersection Summary

Area Type:	Other
Cycle Length:	100
Actuated Cycle Length:	44
Natural Cycle:	50
Control Type:	Actuated-Uncoordinated
Maximum v/c Ratio:	0.40
Intersection Signal Delay:	10.1
Intersection LOS:	B
Intersection Capacity Utilization	43.2%
ICU Level of Service	A
Analysis Period (min)	15

Splits and Phases: 1: Estes Drive Extension & Seawell School Road



Lanes, Volumes, Timings

5: NC 86 (MLK Jr. Blvd) & Estes Drive Extension/Estes Drive

12/13/2017



Lane Group	EBL	EBT	EBR	WBL	WBT	WBR	NBL	NBT	NBR	SBL	SBT	SBR
Lane Configurations												
Traffic Volume (vph)	192	208	60	153	229	274	62	467	167	232	486	178
Future Volume (vph)	192	208	60	153	229	274	62	467	167	232	486	178
Ideal Flow (vphpl)	1900	1900	1900	1900	1900	1900	1900	1900	1900	1900	1900	1900
Grade (%)		0%			1%			1%			-2%	
Storage Length (ft)	225		225	300		250	0		225	0		150
Storage Lanes	1		1	2		1	1		1	1		1
Taper Length (ft)	25			25			25			25		
Lane Util. Factor	1.00	1.00	1.00	0.97	1.00	1.00	1.00	0.95	1.00	1.00	0.95	1.00
Ped Bike Factor									0.97	0.99		
Frt			0.850			0.850			0.850			0.850
Flt Protected	0.950			0.950			0.950			0.950		
Satd. Flow (prot)	1736	1827	1553	3350	1818	1545	1694	3389	1516	1753	3506	1568
Flt Permitted	0.950			0.950			0.313			0.475		
Satd. Flow (perm)	1736	1827	1553	3350	1818	1545	558	3389	1469	871	3506	1568
Right Turn on Red			No			No			No			No
Satd. Flow (RTOR)												
Link Speed (mph)		35			35			35				35
Link Distance (ft)		1360			1121			1058				1059
Travel Time (s)		26.5			21.8			20.6				20.6
Confl. Peds. (#/hr)									4	4		
Peak Hour Factor	0.96	0.96	0.96	0.96	0.96	0.96	0.96	0.96	0.96	0.96	0.96	0.96
Heavy Vehicles (%)	4%	4%	4%	4%	4%	4%	6%	6%	6%	4%	4%	4%
Adj. Flow (vph)	200	217	63	159	239	285	65	486	174	242	506	185
Shared Lane Traffic (%)												
Lane Group Flow (vph)	200	217	63	159	239	285	65	486	174	242	506	185
Enter Blocked Intersection	No	No	No	No	No	No	No	No	No	No	No	No
Lane Alignment	Left	Left	Right	Left	Left	Right	Left	Left	Right	Left	Left	Right
Median Width(ft)		24			24			12				12
Link Offset(ft)		0			0			0				0
Crosswalk Width(ft)		16			16			16				16
Two way Left Turn Lane												
Headway Factor	1.00	1.00	1.00	1.01	1.01	1.01	1.01	1.01	1.01	0.99	0.99	0.99
Turning Speed (mph)	15		9	15		9	15		9	15		9
Turn Type	Prot	NA	pm+ov	Prot	NA	pm+ov	pm+pt	NA	pm+ov	pm+pt	NA	pm+ov
Protected Phases	7	4	5	3	8	1	5	2	3	1	6	7
Permitted Phases			4			8	2		2	6		6
Detector Phase	7	4	5	3	8	1	5	2	3	1	6	7
Switch Phase												
Minimum Initial (s)	7.0	7.0	7.0	7.0	7.0	7.0	7.0	12.0	7.0	7.0	12.0	7.0
Minimum Split (s)	14.0	14.0	15.0	15.0	14.0	15.0	15.0	35.0	15.0	15.0	19.0	14.0
Total Split (s)	37.0	59.0	17.0	20.0	42.0	35.0	17.0	46.0	20.0	35.0	64.0	37.0
Total Split (%)	23.1%	36.9%	10.6%	12.5%	26.3%	21.9%	10.6%	28.8%	12.5%	21.9%	40.0%	23.1%
Yellow Time (s)	5.0	5.0	5.0	5.0	5.0	5.0	5.0	5.0	5.0	5.0	5.0	5.0
All-Red Time (s)	2.0	2.0	2.0	2.0	2.0	2.0	2.0	2.0	2.0	2.0	2.0	2.0
Lost Time Adjust (s)	-2.0	-2.0	-2.0	-2.0	-2.0	-2.0	-2.0	-2.0	-2.0	-2.0	-2.0	-2.0
Total Lost Time (s)	5.0	5.0	5.0	5.0	5.0	5.0	5.0	5.0	5.0	5.0	5.0	5.0
Lead/Lag	Lead	Lag	Lead	Lead	Lag	Lag	Lead	Lead	Lead	Lag	Lag	Lead
Lead-Lag Optimize?	Yes	Yes	Yes	Yes	Yes	Yes	Yes	Yes	Yes	Yes	Yes	Yes

Lanes, Volumes, Timings

5: NC 86 (MLK Jr. Blvd) & Estes Drive Extension/Estes Drive

12/13/2017



Lane Group	EBL	EBT	EBR	WBL	WBT	WBR	NBL	NBT	NBR	SBL	SBT	SBR
Recall Mode	None	None	None	None	None	None	None	C-Max	None	None	C-Max	None
Act Effct Green (s)	25.4	39.7	56.0	13.9	28.3	58.3	56.4	56.4	70.3	75.0	75.0	105.4
Actuated g/C Ratio	0.16	0.25	0.35	0.09	0.18	0.36	0.35	0.35	0.44	0.47	0.47	0.66
v/c Ratio	0.73	0.48	0.12	0.55	0.74	0.51	0.23	0.41	0.27	0.42	0.31	0.18
Control Delay	78.9	53.3	32.5	77.1	76.2	24.6	41.4	42.6	17.1	37.6	29.1	12.2
Queue Delay	0.0	0.0	0.0	0.0	0.0	0.0	0.0	0.0	0.0	0.0	0.0	0.0
Total Delay	78.9	53.3	32.5	77.1	76.2	24.6	41.4	42.6	17.1	37.6	29.1	12.2
LOS	E	D	C	E	E	C	D	D	B	D	C	B
Approach Delay		61.2			54.9			36.4			28.0	
Approach LOS		E			D			D			C	
Queue Length 50th (ft)	201	196	45	82	240	146	46	203	59	155	172	71
Queue Length 95th (ft)	282	250	70	123	322	157	96	294	119	265	258	127
Internal Link Dist (ft)		1280			1041			978			979	
Turn Bay Length (ft)	225		225	300		250			225			150
Base Capacity (vph)	347	616	554	314	420	562	284	1194	659	573	1644	1097
Starvation Cap Reductn	0	0	0	0	0	0	0	0	0	0	0	0
Spillback Cap Reductn	0	0	0	0	0	0	0	0	0	0	0	0
Storage Cap Reductn	0	0	0	0	0	0	0	0	0	0	0	0
Reduced v/c Ratio	0.58	0.35	0.11	0.51	0.57	0.51	0.23	0.41	0.26	0.42	0.31	0.17

Intersection Summary

Area Type: Other
 Cycle Length: 160
 Actuated Cycle Length: 160
 Offset: 104 (65%), Referenced to phase 2:NBTL and 6:SBTL, Start of Green
 Natural Cycle: 80
 Control Type: Actuated-Coordinated
 Maximum v/c Ratio: 0.74
 Intersection Signal Delay: 42.3
 Intersection LOS: D
 Intersection Capacity Utilization 75.5%
 ICU Level of Service D
 Analysis Period (min) 15

Splits and Phases: 5: NC 86 (MLK Jr. Blvd) & Estes Drive Extension/Estes Drive

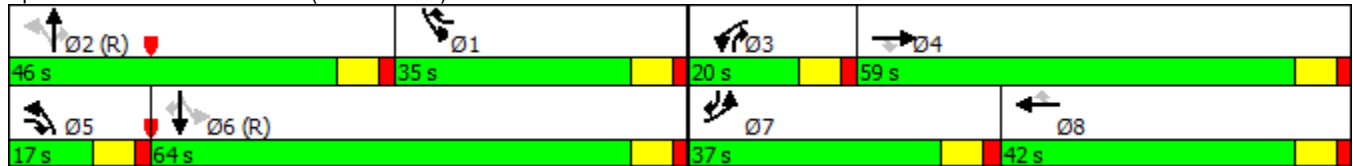

Lanes, Volumes, Timings
 1: Estes Drive Extension & Seawell School Road



	*)	+) +\$	%+)	%+	\$	
) (/	0	1	02	0	
3 , - .	/	0	1	02	0	
4 3 - .	#	#	#	#	#	#
* 4 -5.	6 5			5	6 5	
() (- .	1		2			2
()						
() (- .	2		2			
) 7 8 3	8	8	8	8	8	8
3		8/2				8/2
3 4	8#2		8#2			
48 3 - .	#0	0	2	/11	/#	0
3 4	8#2		8 12			
48 3 - .	#0	0	0	/11	/#	0
\$(\$ 4		%				%
48 3 -\$ 9\$.						
) ! 4 - .	2		2	2		
) !: - .	/0			012	/ 2	
- .	08/			80	08	
! 3	8#1	8#1	8#1	8#1	8#1	8#1
;4<8 3 - .	#		1	0#2		
4) -5.						
) * 3 - .	#		1	0#2		
+ & ! 4	%	%	%	%	%	%
) ; ()	\$()))	\$(
4 4 - .						
) ! 9 - .						
! 4 - .	0			0	0	
)						
4 " 3	8#/	8#/	8	8	8#/	8#/
(4 - .	2	#	2			#
"			=	%;	%;	=
4	1		2		0	1
4		1				0
:	1	1	2		0	1
- .	8	8	8	8	8	8
- .	18	18	18	#8	#8	18
- .	28	28	28	28	0 8	28
-5.	28 5	28 5	28 5	28 5	0 8 5	28 5
> - .	8	8	8	28	28	8
; 6\$ 4 - .	8	8	8#	8	8	8
) ;4< - .	6 8 1	6 8 1	8	6 8	6 8	6 8 1
) - .	28	28	28	28	28	28
) 4) () 4) (
) 46) (9 ? @			>		>	
\$ 4	%	%	%		%	
; + * - .	18	18	1#81	1#81	182	218
; 4 (\$	8 #	8 #	800	800	810	8

Lanes, Volumes, Timings
 1: Estes Drive Extension & Seawell School Road

12/13/2017



Lane Group	SEL	SER	NEL	NET	SWT	SWR
v/c Ratio	0.34	0.62	0.47	0.36	0.79	0.15
Control Delay	32.3	40.1	9.4	6.5	24.3	3.1
Queue Delay	0.0	0.0	0.0	0.0	0.0	0.0
Total Delay	32.3	40.1	9.4	6.5	24.3	3.1
LOS	C	D	A	A	C	A
Approach Delay	37.2			7.3	20.1	
Approach LOS	D			A	C	
Queue Length 50th (ft)	47	82	25	74	256	19
Queue Length 95th (ft)	115	185	58	142	428	32
Internal Link Dist (ft)	782			565	745	
Turn Bay Length (ft)	400		250			75
Base Capacity (vph)	510	456	388	1650	1441	1316
Starvation Cap Reductn	0	0	0	0	0	0
Spillback Cap Reductn	0	0	0	0	0	0
Storage Cap Reductn	0	0	0	0	0	0
Reduced v/c Ratio	0.23	0.42	0.45	0.26	0.48	0.13

Intersection Summary

Area Type: Other
 Cycle Length: 100
 Actuated Cycle Length: 74.3
 Natural Cycle: 60
 Control Type: Actuated-Uncoordinated
 Maximum v/c Ratio: 0.79
 Intersection Signal Delay: 18.7
 Intersection Capacity Utilization 62.0%
 Analysis Period (min) 15
 Intersection LOS: B
 ICU Level of Service B



























Splits and Phases: 1: Estes Drive Extension & Seawell School Road



Lanes, Volumes, Timings

5: NC 86 (MLK Jr. Blvd) & Estes Drive Extension/Estes Drive

12/13/2017

												
Lane Group	EBL	EBT	EBR	WBL	WBT	WBR	NBL	NBT	NBR	SBL	SBT	SBR
Lane Configurations				 				 			 	
Traffic Volume (vph)	322	272	124	173	315	444	98	1132	180	247	700	319
Future Volume (vph)	322	272	124	173	315	444	98	1132	180	247	700	319
Ideal Flow (vphpl)	1900	1900	1900	1900	1900	1900	1900	1900	1900	1900	1900	1900
Grade (%)		0%			1%			1%			-2%	
Storage Length (ft)	225		225	300		250	0		225	0		150
Storage Lanes	1		1	2		1	1		1	1		1
Taper Length (ft)	25			25			25			25		
Lane Util. Factor	1.00	1.00	1.00	0.97	1.00	1.00	1.00	0.95	1.00	1.00	0.95	1.00
Ped Bike Factor									0.96			
Frt			0.850			0.850			0.850			0.850
Flt Protected	0.950			0.950			0.950			0.950		
Satd. Flow (prot)	1770	1863	1583	3416	1853	1575	1761	3522	1575	1787	3575	1599
Flt Permitted	0.950			0.950			0.195			0.071		
Satd. Flow (perm)	1770	1863	1583	3416	1853	1575	361	3522	1519	134	3575	1599
Right Turn on Red			No			No			No			No
Satd. Flow (RTOR)												
Link Speed (mph)		35			35			35			35	
Link Distance (ft)		1360			1121			1058			1059	
Travel Time (s)		26.5			21.8			20.6			20.6	
Confl. Peds. (#/hr)									5	5		
Peak Hour Factor	0.95	0.95	0.95	0.95	0.95	0.95	0.95	0.95	0.95	0.95	0.95	0.95
Adj. Flow (vph)	339	286	131	182	332	467	103	1192	189	260	737	336
Shared Lane Traffic (%)												
Lane Group Flow (vph)	339	286	131	182	332	467	103	1192	189	260	737	336
Enter Blocked Intersection	No	No	No	No	No	No	No	No	No	No	No	No
Lane Alignment	Left	Left	Right	Left	Left	Right	Left	Left	Right	Left	Left	Right
Median Width(ft)		24			24			12			12	
Link Offset(ft)		0			0			0			0	
Crosswalk Width(ft)		16			16			16			16	
Two way Left Turn Lane												
Headway Factor	1.00	1.00	1.00	1.01	1.01	1.01	1.01	1.01	1.01	0.99	0.99	0.99
Turning Speed (mph)	15		9	15		9	15		9	15		9
Turn Type	Prot	NA	pm+ov	Prot	NA	pm+ov	pm+pt	NA	pm+ov	pm+pt	NA	pm+ov
Protected Phases	7	4	5	3	8	1	5	2	3	1	6	7
Permitted Phases			4			8	2		2	6		6
Detector Phase	7	4	5	3	8	1	5	2	3	1	6	7
Switch Phase												
Minimum Initial (s)	7.0	7.0	7.0	7.0	7.0	7.0	7.0	12.0	7.0	7.0	12.0	7.0
Minimum Split (s)	14.0	14.0	15.0	15.0	14.0	15.0	15.0	35.0	15.0	15.0	19.0	14.0
Total Split (s)	38.0	57.0	15.0	20.0	39.0	32.0	15.0	71.0	20.0	32.0	88.0	38.0
Total Split (%)	21.1%	31.7%	8.3%	11.1%	21.7%	17.8%	8.3%	39.4%	11.1%	17.8%	48.9%	21.1%
Yellow Time (s)	5.0	5.0	5.0	5.0	5.0	5.0	5.0	5.0	5.0	5.0	5.0	5.0
All-Red Time (s)	2.0	2.0	2.0	2.0	2.0	2.0	2.0	2.0	2.0	2.0	2.0	2.0
Lost Time Adjust (s)	-2.0	-2.0	-2.0	-2.0	-2.0	-2.0	-2.0	-2.0	-2.0	-2.0	-2.0	-2.0
Total Lost Time (s)	5.0	5.0	5.0	5.0	5.0	5.0	5.0	5.0	5.0	5.0	5.0	5.0
Lead/Lag	Lead	Lag	Lead	Lead	Lag	Lag	Lead	Lead	Lead	Lag	Lag	Lead
Lead-Lag Optimize?	Yes	Yes	Yes	Yes	Yes	Yes	Yes	Yes	Yes	Yes	Yes	Yes
Recall Mode	None	None	None	None	None	None	None	C-Max	None	None	C-Max	None

Lanes, Volumes, Timings

5: NC 86 (MLK Jr. Blvd) & Estes Drive Extension/Estes Drive

12/13/2017



Lane Group	EBL	EBT	EBR	WBL	WBT	WBR	NBL	NBT	NBR	SBL	SBT	SBR
Act Effect Green (s)	33.0	52.4	67.4	14.6	34.0	61.0	66.0	66.0	80.6	83.0	83.0	121.0
Actuated g/C Ratio	0.18	0.29	0.37	0.08	0.19	0.34	0.37	0.37	0.45	0.46	0.46	0.67
v/c Ratio	1.05	0.53	0.22	0.66	0.95	0.88	0.49	0.92	0.28	0.84	0.45	0.31
Control Delay	130.5	57.8	39.8	92.2	107.8	53.4	46.8	66.8	17.8	90.9	34.0	13.2
Queue Delay	0.0	0.0	0.0	0.0	0.0	0.0	0.0	0.0	0.0	0.0	0.0	0.0
Total Delay	130.5	57.8	39.8	92.2	107.8	53.4	46.8	66.8	17.8	90.9	34.0	13.2
LOS	F	E	D	F	F	D	D	E	B	F	C	B
Approach Delay		87.3			79.0			59.2				39.9
Approach LOS		F			E			E				D
Queue Length 50th (ft)	~432	286	106	109	393	323	82	711	84	250	308	156
Queue Length 95th (ft)	#647	390	164	155	#597	#478	132	#824	122	#404	367	212
Internal Link Dist (ft)		1280			1041			978				979
Turn Bay Length (ft)	225		225	300		250			225			150
Base Capacity (vph)	324	542	593	284	350	533	210	1292	688	309	1648	1074
Starvation Cap Reductn	0	0	0	0	0	0	0	0	0	0	0	0
Spillback Cap Reductn	0	0	0	0	0	0	0	0	0	0	0	0
Storage Cap Reductn	0	0	0	0	0	0	0	0	0	0	0	0
Reduced v/c Ratio	1.05	0.53	0.22	0.64	0.95	0.88	0.49	0.92	0.27	0.84	0.45	0.31

Intersection Summary

Area Type: Other
 Cycle Length: 180
 Actuated Cycle Length: 180
 Offset: 88 (49%), Referenced to phase 2:NBTL and 6:SBTL, Start of Green
 Natural Cycle: 110
 Control Type: Actuated-Coordinated
 Maximum v/c Ratio: 1.05
 Intersection Signal Delay: 62.5 Intersection LOS: E
 Intersection Capacity Utilization 96.1% ICU Level of Service F
 Analysis Period (min) 15
 ~ Volume exceeds capacity, queue is theoretically infinite.
 Queue shown is maximum after two cycles.
 # 95th percentile volume exceeds capacity, queue may be longer.
 Queue shown is maximum after two cycles.

Splits and Phases: 5: NC 86 (MLK Jr. Blvd) & Estes Drive Extension/Estes Drive

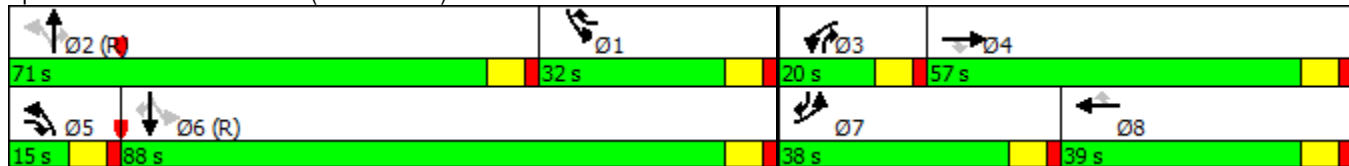

Appendix F – Synchro Unsignalized HCM Analysis
Output

Intersection

Int Delay, s/veh 0.1

Movement EBL EBT WBT WBR SBL SBR

Lane Configurations						
Traffic Vol, veh/h	1	621	336	8	5	0
Future Vol, veh/h	1	621	336	8	5	0
Conflicting Peds, #/hr	0	0	0	0	0	0
Sign Control	Free	Free	Free	Free	Stop	Stop
RT Channelized	-	None	-	None	-	None
Storage Length	125	-	-	-	75	0
Veh in Median Storage, #	-	0	0	-	0	-
Grade, %	-	0	0	-	0	-
Peak Hour Factor	90	90	90	90	90	90
Heavy Vehicles, %	2	2	7	7	40	2
Mvmt Flow	1	690	373	9	6	0

Major/Minor Major1 Major2 Minor2

Conflicting Flow All	382	0	-	0	1070	378
Stage 1	-	-	-	-	378	-
Stage 2	-	-	-	-	692	-
Critical Hdwy	4.12	-	-	-	6.8	6.22
Critical Hdwy Stg 1	-	-	-	-	5.8	-
Critical Hdwy Stg 2	-	-	-	-	5.8	-
Follow-up Hdwy	2.218	-	-	-	3.86	3.318
Pot Cap-1 Maneuver	1176	-	-	-	208	669
Stage 1	-	-	-	-	617	-
Stage 2	-	-	-	-	433	-
Platoon blocked, %		-	-	-		
Mov Cap-1 Maneuver	1176	-	-	-	208	669
Mov Cap-2 Maneuver	-	-	-	-	208	-
Stage 1	-	-	-	-	617	-
Stage 2	-	-	-	-	433	-

Approach EB WB SB

HCM Control Delay, s	0	0	22.8
HCM LOS			C

Minor Lane/Major Mvmt EBL EBT WBT WBR SBLn1 SBLn2

Capacity (veh/h)	1176	-	-	-	208	-
HCM Lane V/C Ratio	0.001	-	-	-	0.027	-
HCM Control Delay (s)	8.1	-	-	-	22.8	0
HCM Lane LOS	A	-	-	-	C	A
HCM 95th %tile Q(veh)	0	-	-	-	0.1	-

HCM 2010 TWSC
4: Estes Drive Extension & Airport Drive

12/13/2017

Intersection						
Int Delay, s/veh	1.1					
Movement	NWL	NWR	NET	NER	SWL	SWT
Lane Configurations						
Traffic Vol, veh/h	25	21	744	88	12	316
Future Vol, veh/h	25	21	744	88	12	316
Conflicting Peds, #/hr	0	0	0	0	0	0
Sign Control	Stop	Stop	Free	Free	Free	Free
RT Channelized	-	None	-	None	-	None
Storage Length	0	-	-	-	-	-
Veh in Median Storage, #	0	-	0	-	-	0
Grade, %	0	-	0	-	-	0
Peak Hour Factor	91	91	91	91	91	91
Heavy Vehicles, %	8	14	2	2	17	7
Mvmt Flow	27	23	818	97	13	347

Major/Minor	Minor1	Major1	Major2		
Conflicting Flow All	1240	866	0	0	914
Stage 1	866	-	-	-	-
Stage 2	374	-	-	-	-
Critical Hdwy	6.48	6.34	-	-	4.27
Critical Hdwy Stg 1	5.48	-	-	-	-
Critical Hdwy Stg 2	5.48	-	-	-	-
Follow-up Hdwy	3.572	3.426	-	-	2.353
Pot Cap-1 Maneuver	188	336	-	-	687
Stage 1	402	-	-	-	-
Stage 2	683	-	-	-	-
Platoon blocked, %			-	-	-
Mov Cap-1 Maneuver	184	336	-	-	687
Mov Cap-2 Maneuver	184	-	-	-	-
Stage 1	402	-	-	-	-
Stage 2	667	-	-	-	-

Approach	NW	NE	SW
HCM Control Delay, s	24.8	0	0.4
HCM LOS	C		

Minor Lane/Major Mvmt	NET	NER	NWLn1	SWL	SWT
Capacity (veh/h)	-	-	232	687	-
HCM Lane V/C Ratio	-	-	0.218	0.019	-
HCM Control Delay (s)	-	-	24.8	10.3	0
HCM Lane LOS	-	-	C	B	A
HCM 95th %tile Q(veh)	-	-	0.8	0.1	-

Intersection

Int Delay, s/veh 1.4

Movement EBL EBR NBL NBT SBT SBR

Lane Configurations	↙	↗	↙	↑↑	↑↑	
Traffic Vol, veh/h	3	92	77	513	1055	130
Future Vol, veh/h	3	92	77	513	1055	130
Conflicting Peds, #/hr	10	0	1	0	0	1
Sign Control	Stop	Stop	Free	Free	Free	Free
RT Channelized	-	None	-	None	-	None
Storage Length	125	0	0	-	-	-
Veh in Median Storage, #	0	-	-	0	0	-
Grade, %	0	-	-	0	0	-
Peak Hour Factor	93	93	93	93	93	93
Heavy Vehicles, %	6	6	6	6	3	3
Mvmt Flow	3	99	83	552	1134	140

Major/Minor Minor2 Major1 Major2

Conflicting Flow All	1656	638	1275	0	-	0
Stage 1	1205	-	-	-	-	-
Stage 2	451	-	-	-	-	-
Critical Hdwy	6.92	7.02	4.22	-	-	-
Critical Hdwy Stg 1	5.92	-	-	-	-	-
Critical Hdwy Stg 2	5.92	-	-	-	-	-
Follow-up Hdwy	3.56	3.36	2.26	-	-	-
Pot Cap-1 Maneuver	85	410	519	-	-	-
Stage 1	239	-	-	-	-	-
Stage 2	597	-	-	-	-	-
Platoon blocked, %				-	-	-
Mov Cap-1 Maneuver	71	410	519	-	-	-
Mov Cap-2 Maneuver	71	-	-	-	-	-
Stage 1	239	-	-	-	-	-
Stage 2	501	-	-	-	-	-

Approach EB NB SB

HCM Control Delay, s 17.9 1.7 0
HCM LOS C

Minor Lane/Major Mvmt NBL NBT EBLn1 EBLn2 SBT SBR

Capacity (veh/h)	519	-	71	410	-	-
HCM Lane V/C Ratio	0.16	-	0.045	0.241	-	-
HCM Control Delay (s)	13.2	-	58.1	16.6	-	-
HCM Lane LOS	B	-	F	C	-	-
HCM 95th %tile Q(veh)	0.6	-	0.1	0.9	-	-

Intersection

Int Delay, s/veh 0.1

Movement	EBL	EBT	WBT	WBR	SBL	SBR
Lane Configurations	↖	↑	↗		↖	↗
Traffic Vol, veh/h	4	402	390	8	4	0
Future Vol, veh/h	4	402	390	8	4	0
Conflicting Peds, #/hr	0	0	0	0	0	0
Sign Control	Free	Free	Free	Free	Stop	Stop
RT Channelized	-	None	-	None	-	None
Storage Length	125	-	-	-	75	0
Veh in Median Storage, #	-	0	0	-	0	-
Grade, %	-	0	0	-	0	-
Peak Hour Factor	90	90	90	90	90	90
Heavy Vehicles, %	3	3	4	4	2	2
Mvmt Flow	4	447	433	9	4	0

Major/Minor

	Major1	Major2	Minor2		
Conflicting Flow All	442	0	0	894	438
Stage 1	-	-	-	438	-
Stage 2	-	-	-	456	-
Critical Hdwy	4.13	-	-	6.42	6.22
Critical Hdwy Stg 1	-	-	-	5.42	-
Critical Hdwy Stg 2	-	-	-	5.42	-
Follow-up Hdwy	2.227	-	-	3.518	3.318
Pot Cap-1 Maneuver	1113	-	-	312	619
Stage 1	-	-	-	651	-
Stage 2	-	-	-	638	-
Platoon blocked, %	-	-	-	-	-
Mov Cap-1 Maneuver	1113	-	-	311	619
Mov Cap-2 Maneuver	-	-	-	311	-
Stage 1	-	-	-	651	-
Stage 2	-	-	-	636	-

Approach

	EB	WB	SB
HCM Control Delay, s	0.1	0	16.7
HCM LOS			C

Minor Lane/Major Mvmt

	EBL	EBT	WBT	WBR	SBLn1	SBLn2
Capacity (veh/h)	1113	-	-	-	311	-
HCM Lane V/C Ratio	0.004	-	-	-	0.014	-
HCM Control Delay (s)	8.2	-	-	-	16.7	0
HCM Lane LOS	A	-	-	-	C	A
HCM 95th %tile Q(veh)	0	-	-	-	0	-

Intersection						
Int Delay, s/veh	0.8					
Movement	NWL	NWR	NET	NER	SWL	SWT
Lane Configurations						
Traffic Vol, veh/h	22	17	363	38	12	385
Future Vol, veh/h	22	17	363	38	12	385
Conflicting Peds, #/hr	0	0	0	0	0	0
Sign Control	Stop	Stop	Free	Free	Free	Free
RT Channelized	-	None	-	None	-	None
Storage Length	0	-	-	-	-	-
Veh in Median Storage, #	0	-	0	-	-	0
Grade, %	0	-	0	-	-	0
Peak Hour Factor	95	95	95	95	95	95
Heavy Vehicles, %	18	6	2	8	2	3
Mvmt Flow	23	18	382	40	13	405

Major/Minor	Minor1	Major1	Major2			
Conflicting Flow All	833	402	0	0	422	0
Stage 1	402	-	-	-	-	-
Stage 2	431	-	-	-	-	-
Critical Hdwy	6.58	6.26	-	-	4.12	-
Critical Hdwy Stg 1	5.58	-	-	-	-	-
Critical Hdwy Stg 2	5.58	-	-	-	-	-
Follow-up Hdwy	3.662	3.354	-	-	2.218	-
Pot Cap-1 Maneuver	318	640	-	-	1137	-
Stage 1	642	-	-	-	-	-
Stage 2	623	-	-	-	-	-
Platoon blocked, %			-	-		
Mov Cap-1 Maneuver	313	640	-	-	1137	-
Mov Cap-2 Maneuver	313	-	-	-	-	-
Stage 1	642	-	-	-	-	-
Stage 2	614	-	-	-	-	-

Approach	NW	NE	SW
HCM Control Delay, s	14.9	0	0.2
HCM LOS	B		

Minor Lane/Major Mvmt	NET	NERNWLn1	SWL	SWT
Capacity (veh/h)	-	-	403	1137
HCM Lane V/C Ratio	-	-	0.102	0.011
HCM Control Delay (s)	-	-	14.9	8.2
HCM Lane LOS	-	-	B	A
HCM 95th %tile Q(veh)	-	-	0.3	0

Intersection						
Int Delay, s/veh	1.4					
Movement	EBL	EBR	NBL	NBT	SBT	SBR
Lane Configurations	↖	↗	↖	↕↕	↕↗	
Traffic Vol, veh/h	20	58	74	574	591	30
Future Vol, veh/h	20	58	74	574	591	30
Conflicting Peds, #/hr	1	0	1	0	0	1
Sign Control	Stop	Stop	Free	Free	Free	Free
RT Channelized	-	None	-	None	-	None
Storage Length	125	0	0	-	-	-
Veh in Median Storage, #	0	-	-	0	0	-
Grade, %	0	-	-	0	0	-
Peak Hour Factor	92	92	92	92	92	92
Heavy Vehicles, %	5	5	6	6	3	3
Mvmt Flow	22	63	80	624	642	33

Major/Minor	Minor2	Major1	Major2			
Conflicting Flow All	1134	339	676	0	-	0
Stage 1	660	-	-	-	-	-
Stage 2	474	-	-	-	-	-
Critical Hdwy	6.9	7	4.22	-	-	-
Critical Hdwy Stg 1	5.9	-	-	-	-	-
Critical Hdwy Stg 2	5.9	-	-	-	-	-
Follow-up Hdwy	3.55	3.35	2.26	-	-	-
Pot Cap-1 Maneuver	192	648	885	-	-	-
Stage 1	468	-	-	-	-	-
Stage 2	584	-	-	-	-	-
Platoon blocked, %				-	-	-
Mov Cap-1 Maneuver	174	647	885	-	-	-
Mov Cap-2 Maneuver	174	-	-	-	-	-
Stage 1	468	-	-	-	-	-
Stage 2	531	-	-	-	-	-

Approach	EB	NB	SB
HCM Control Delay, s	15.7	1.1	0
HCM LOS	C		

Minor Lane/Major Mvmt	NBL	NBT	EBLn1	EBLn2	SBT	SBR
Capacity (veh/h)	885	-	174	647	-	-
HCM Lane V/C Ratio	0.091	-	0.125	0.097	-	-
HCM Control Delay (s)	9.5	-	28.6	11.2	-	-
HCM Lane LOS	A	-	D	B	-	-
HCM 95th %tile Q(veh)	0.3	-	0.4	0.3	-	-

Intersection

Int Delay, s/veh 0.2

Movement EBL EBT WBT WBR SBL SBR

Lane Configurations	↙	↑	↘		↙	↘
Traffic Vol, veh/h	2	501	749	7	7	1
Future Vol, veh/h	2	501	749	7	7	1
Conflicting Peds, #/hr	0	0	0	0	0	0
Sign Control	Free	Free	Free	Free	Stop	Stop
RT Channelized	-	None	-	None	-	None
Storage Length	125	-	-	-	75	0
Veh in Median Storage, #	-	0	0	-	0	-
Grade, %	-	0	0	-	0	-
Peak Hour Factor	95	95	95	95	95	95
Heavy Vehicles, %	2	2	2	2	28	2
Mvmt Flow	2	527	788	7	7	1

Major/Minor Major1 Major2 Minor2

Conflicting Flow All	796	0	-	0	1324	792
Stage 1	-	-	-	-	792	-
Stage 2	-	-	-	-	532	-
Critical Hdwy	4.12	-	-	-	6.68	6.22
Critical Hdwy Stg 1	-	-	-	-	5.68	-
Critical Hdwy Stg 2	-	-	-	-	5.68	-
Follow-up Hdwy	2.218	-	-	-	3.752	3.318
Pot Cap-1 Maneuver	826	-	-	-	152	389
Stage 1	-	-	-	-	404	-
Stage 2	-	-	-	-	540	-
Platoon blocked, %		-	-	-		
Mov Cap-1 Maneuver	826	-	-	-	152	389
Mov Cap-2 Maneuver	-	-	-	-	152	-
Stage 1	-	-	-	-	404	-
Stage 2	-	-	-	-	539	-

Approach EB WB SB

HCM Control Delay, s	0	0	28
HCM LOS			D

Minor Lane/Major Mvmt EBL EBT WBT WBR SBLn1 SBLn2

Capacity (veh/h)	826	-	-	-	152	389
HCM Lane V/C Ratio	0.003	-	-	-	0.048	0.003
HCM Control Delay (s)	9.4	-	-	-	29.9	14.3
HCM Lane LOS	A	-	-	-	D	B
HCM 95th %tile Q(veh)	0	-	-	-	0.2	0

HCM 2010 TWSC
4: Estes Drive Extension & Airport Drive

12/13/2017

Intersection						
Int Delay, s/veh	5.6					
Movement	NWL	NWR	NET	NER	SWL	SWT
Lane Configurations						
Traffic Vol, veh/h	106	38	476	35	6	659
Future Vol, veh/h	106	38	476	35	6	659
Conflicting Peds, #/hr	0	0	0	0	0	0
Sign Control	Stop	Stop	Free	Free	Free	Free
RT Channelized	-	None	-	None	-	None
Storage Length	0	-	-	-	-	-
Veh in Median Storage, #	0	-	0	-	-	0
Grade, %	0	-	0	-	-	0
Peak Hour Factor	93	93	93	93	93	93
Heavy Vehicles, %	5	4	2	6	2	2
Mvmt Flow	114	41	512	38	6	709

Major/Minor	Minor1	Major1	Major2		
Conflicting Flow All	1253	531	0	0	549
Stage 1	531	-	-	-	-
Stage 2	722	-	-	-	-
Critical Hdwy	6.45	6.24	-	-	4.12
Critical Hdwy Stg 1	5.45	-	-	-	-
Critical Hdwy Stg 2	5.45	-	-	-	-
Follow-up Hdwy	3.545	3.336	-	-	2.218
Pot Cap-1 Maneuver	187	544	-	-	1021
Stage 1	584	-	-	-	-
Stage 2	476	-	-	-	-
Platoon blocked, %					
Mov Cap-1 Maneuver	185	544	-	-	1021
Mov Cap-2 Maneuver	185	-	-	-	-
Stage 1	584	-	-	-	-
Stage 2	471	-	-	-	-

Approach	NW	NE	SW
HCM Control Delay, s	50.7	0	0.1
HCM LOS	F		

Minor Lane/Major Mvmt	NET	NERNWLn1	SWL	SWT
Capacity (veh/h)	-	-	224	1021
HCM Lane V/C Ratio	-	-	0.691	0.006
HCM Control Delay (s)	-	-	50.7	8.5
HCM Lane LOS	-	-	F	A
HCM 95th %tile Q(veh)	-	-	4.4	0

Intersection						
Int Delay, s/veh	1.6					
Movement	EBL	EBR	NBL	NBT	SBT	SBR
Lane Configurations	↙	↗	↙	↑↑	↑↑	
Traffic Vol, veh/h	36	44	43	1210	758	6
Future Vol, veh/h	36	44	43	1210	758	6
Conflicting Peds, #/hr	4	0	2	0	0	2
Sign Control	Stop	Stop	Free	Free	Free	Free
RT Channelized	-	None	-	None	-	None
Storage Length	125	0	0	-	-	-
Veh in Median Storage, #	0	-	-	0	0	-
Grade, %	0	-	-	0	0	-
Peak Hour Factor	94	94	94	94	94	94
Heavy Vehicles, %	6	6	7	2	2	2
Mvmt Flow	38	47	46	1287	806	6

Major/Minor	Minor2	Major1	Major2			
Conflicting Flow All	1551	408	815	0	-	0
Stage 1	812	-	-	-	-	-
Stage 2	739	-	-	-	-	-
Critical Hdwy	6.92	7.02	4.24	-	-	-
Critical Hdwy Stg 1	5.92	-	-	-	-	-
Critical Hdwy Stg 2	5.92	-	-	-	-	-
Follow-up Hdwy	3.56	3.36	2.27	-	-	-
Pot Cap-1 Maneuver	100	581	777	-	-	-
Stage 1	387	-	-	-	-	-
Stage 2	423	-	-	-	-	-
Platoon blocked, %				-	-	-
Mov Cap-1 Maneuver	94	580	777	-	-	-
Mov Cap-2 Maneuver	94	-	-	-	-	-
Stage 1	386	-	-	-	-	-
Stage 2	397	-	-	-	-	-

Approach	EB	NB	SB
HCM Control Delay, s	36.8	0.3	0
HCM LOS	E		

Minor Lane/Major Mvmt	NBL	NBT	EBLn1	EBLn2	SBT	SBR
Capacity (veh/h)	777	-	94	580	-	-
HCM Lane V/C Ratio	0.059	-	0.407	0.081	-	-
HCM Control Delay (s)	9.9	-	67.4	11.8	-	-
HCM Lane LOS	A	-	F	B	-	-
HCM 95th %tile Q(veh)	0.2	-	1.7	0.3	-	-

Intersection

Int Delay, s/veh 0.1

Movement	EBL	EBT	WBT	WBR	SBL	SBR
Lane Configurations	↙	↑	↘		↙	↘
Traffic Vol, veh/h	1	856	354	8	5	0
Future Vol, veh/h	1	856	354	8	5	0
Conflicting Peds, #/hr	0	0	0	0	0	0
Sign Control	Free	Free	Free	Free	Stop	Stop
RT Channelized	-	None	-	None	-	None
Storage Length	125	-	-	-	75	0
Veh in Median Storage, #	-	0	0	-	0	-
Grade, %	-	0	0	-	0	-
Peak Hour Factor	90	90	90	90	90	90
Heavy Vehicles, %	2	2	7	7	40	2
Mvmt Flow	1	951	393	9	6	0

Major/Minor	Major1	Major2	Minor2
Conflicting Flow All	402	0	0
Stage 1	-	-	-
Stage 2	-	-	-
Critical Hdwy	4.12	-	-
Critical Hdwy Stg 1	-	-	-
Critical Hdwy Stg 2	-	-	-
Follow-up Hdwy	2.218	-	-
Pot Cap-1 Maneuver	1157	-	-
Stage 1	-	-	-
Stage 2	-	-	-
Platoon blocked, %	-	-	-
Mov Cap-1 Maneuver	1157	-	-
Mov Cap-2 Maneuver	-	-	-
Stage 1	-	-	-
Stage 2	-	-	-

Approach	EB	WB	SB
HCM Control Delay, s	0	0	32.2
HCM LOS			D

Minor Lane/Major Mvmt	EBL	EBT	WBT	WBR	SBLn1	SBLn2
Capacity (veh/h)	1157	-	-	-	138	-
HCM Lane V/C Ratio	0.001	-	-	-	0.04	-
HCM Control Delay (s)	8.1	-	-	-	32.2	0
HCM Lane LOS	A	-	-	-	D	A
HCM 95th %tile Q(veh)	0	-	-	-	0.1	-

Intersection

Int Delay, s/veh 1.1

Movement NWL NWR NET NER SWL SWT

Lane Configurations						
Traffic Vol, veh/h	26	22	776	92	12	334
Future Vol, veh/h	26	22	776	92	12	334
Conflicting Peds, #/hr	0	0	0	0	0	0
Sign Control	Stop	Stop	Free	Free	Free	Free
RT Channelized	-	None	-	None	-	None
Storage Length	0	-	-	-	-	-
Veh in Median Storage, #	0	-	0	-	-	0
Grade, %	0	-	0	-	-	0
Peak Hour Factor	91	91	91	91	91	91
Heavy Vehicles, %	8	14	2	2	17	7
Mvmt Flow	29	24	853	101	13	367

Major/Minor Minor1 Major1 Major2

Conflicting Flow All	1296	903	0	0	954	0
Stage 1	903	-	-	-	-	-
Stage 2	393	-	-	-	-	-
Critical Hdwy	6.48	6.34	-	-	4.27	-
Critical Hdwy Stg 1	5.48	-	-	-	-	-
Critical Hdwy Stg 2	5.48	-	-	-	-	-
Follow-up Hdwy	3.572	3.426	-	-	2.353	-
Pot Cap-1 Maneuver	174	319	-	-	663	-
Stage 1	386	-	-	-	-	-
Stage 2	669	-	-	-	-	-
Platoon blocked, %			-	-		
Mov Cap-1 Maneuver	170	319	-	-	663	-
Mov Cap-2 Maneuver	170	-	-	-	-	-
Stage 1	386	-	-	-	-	-
Stage 2	652	-	-	-	-	-

Approach NW NE SW

HCM Control Delay, s	27	0	0.4
HCM LOS	D		

Minor Lane/Major Mvmt NET NERNWLn1 SWL SWT

Capacity (veh/h)	-	-	216	663	-
HCM Lane V/C Ratio	-	-	0.244	0.02	-
HCM Control Delay (s)	-	-	27	10.5	0
HCM Lane LOS	-	-	D	B	A
HCM 95th %tile Q(veh)	-	-	0.9	0.1	-

Intersection						
Int Delay, s/veh	1.5					
Movement	EBL	EBR	NBL	NBT	SBT	SBR
Lane Configurations						
Traffic Vol, veh/h	3	96	80	542	1123	135
Future Vol, veh/h	3	96	80	542	1123	135
Conflicting Peds, #/hr	10	0	1	0	0	1
Sign Control	Stop	Stop	Free	Free	Free	Free
RT Channelized	-	None	-	None	-	None
Storage Length	125	0	0	-	-	-
Veh in Median Storage, #	0	-	-	0	0	-
Grade, %	0	-	-	0	0	-
Peak Hour Factor	93	93	93	93	93	93
Heavy Vehicles, %	6	6	6	6	3	3
Mvmt Flow	3	103	86	583	1208	145

Major/Minor	Minor2	Major1	Major2			
Conflicting Flow All	1754	677	1354	0	-	0
Stage 1	1281	-	-	-	-	-
Stage 2	473	-	-	-	-	-
Critical Hdwy	6.92	7.02	4.22	-	-	-
Critical Hdwy Stg 1	5.92	-	-	-	-	-
Critical Hdwy Stg 2	5.92	-	-	-	-	-
Follow-up Hdwy	3.56	3.36	2.26	-	-	-
Pot Cap-1 Maneuver	73	386	484	-	-	-
Stage 1	217	-	-	-	-	-
Stage 2	582	-	-	-	-	-
Platoon blocked, %				-	-	-
Mov Cap-1 Maneuver	60	386	484	-	-	-
Mov Cap-2 Maneuver	60	-	-	-	-	-
Stage 1	217	-	-	-	-	-
Stage 2	478	-	-	-	-	-

Approach	EB	NB	SB
HCM Control Delay, s	19.2	1.8	0
HCM LOS	C		

Minor Lane/Major Mvmt	NBL	NBT	EBLn1	EBLn2	SBT	SBR
Capacity (veh/h)	484	-	60	386	-	-
HCM Lane V/C Ratio	0.178	-	0.054	0.267	-	-
HCM Control Delay (s)	14	-	68.4	17.7	-	-
HCM Lane LOS	B	-	F	C	-	-
HCM 95th %tile Q(veh)	0.6	-	0.2	1.1	-	-

Intersection

Int Delay, s/veh 0.1

Movement	EBL	EBT	WBT	WBR	SBL	SBR
Lane Configurations	↖	↑	↗		↖	↗
Traffic Vol, veh/h	4	421	410	8	4	0
Future Vol, veh/h	4	421	410	8	4	0
Conflicting Peds, #/hr	0	0	0	0	0	0
Sign Control	Free	Free	Free	Free	Stop	Stop
RT Channelized	-	None	-	None	-	None
Storage Length	125	-	-	-	75	0
Veh in Median Storage, #	-	0	0	-	0	-
Grade, %	-	0	0	-	0	-
Peak Hour Factor	90	90	90	90	90	90
Heavy Vehicles, %	3	3	4	4	2	2
Mvmt Flow	4	468	456	9	4	0

Major/Minor

	Major1	Major2	Minor2		
Conflicting Flow All	464	0	-	0	937
Stage 1	-	-	-	-	460
Stage 2	-	-	-	-	477
Critical Hdwy	4.13	-	-	-	6.42
Critical Hdwy Stg 1	-	-	-	-	5.42
Critical Hdwy Stg 2	-	-	-	-	5.42
Follow-up Hdwy	2.227	-	-	-	3.518
Pot Cap-1 Maneuver	1092	-	-	-	294
Stage 1	-	-	-	-	636
Stage 2	-	-	-	-	624
Platoon blocked, %		-	-	-	
Mov Cap-1 Maneuver	1092	-	-	-	293
Mov Cap-2 Maneuver	-	-	-	-	293
Stage 1	-	-	-	-	636
Stage 2	-	-	-	-	622

Approach

	EB	WB	SB
HCM Control Delay, s	0.1	0	17.5
HCM LOS			C

Minor Lane/Major Mvmt

	EBL	EBT	WBT	WBR	SBLn1	SBLn2
Capacity (veh/h)	1092	-	-	-	293	-
HCM Lane V/C Ratio	0.004	-	-	-	0.015	-
HCM Control Delay (s)	8.3	-	-	-	17.5	0
HCM Lane LOS	A	-	-	-	C	A
HCM 95th %tile Q(veh)	0	-	-	-	0	-

HCM 2010 TWSC
 4: Estes Drive Extension & Airport Drive

12/13/2017

Intersection						
Int Delay, s/veh	0.8					
Movement	NWL	NWR	NET	NER	SWL	SWT
Lane Configurations						
Traffic Vol, veh/h	23	18	381	40	12	404
Future Vol, veh/h	23	18	381	40	12	404
Conflicting Peds, #/hr	0	0	0	0	0	0
Sign Control	Stop	Stop	Free	Free	Free	Free
RT Channelized	-	None	-	None	-	None
Storage Length	0	-	-	-	-	-
Veh in Median Storage, #	0	-	0	-	-	0
Grade, %	0	-	0	-	-	0
Peak Hour Factor	95	95	95	95	95	95
Heavy Vehicles, %	18	6	2	8	2	3
Mvmt Flow	24	19	401	42	13	425

Major/Minor	Minor1	Major1	Major2			
Conflicting Flow All	873	422	0	0	443	0
Stage 1	422	-	-	-	-	-
Stage 2	451	-	-	-	-	-
Critical Hdwy	6.58	6.26	-	-	4.12	-
Critical Hdwy Stg 1	5.58	-	-	-	-	-
Critical Hdwy Stg 2	5.58	-	-	-	-	-
Follow-up Hdwy	3.662	3.354	-	-	2.218	-
Pot Cap-1 Maneuver	301	623	-	-	1117	-
Stage 1	629	-	-	-	-	-
Stage 2	609	-	-	-	-	-
Platoon blocked, %			-	-		
Mov Cap-1 Maneuver	296	623	-	-	1117	-
Mov Cap-2 Maneuver	296	-	-	-	-	-
Stage 1	629	-	-	-	-	-
Stage 2	600	-	-	-	-	-

Approach	NW	NE	SW
HCM Control Delay, s	15.5	0	0.2
HCM LOS	C		

Minor Lane/Major Mvmt	NET	NER	NWLn1	SWL	SWT
Capacity (veh/h)	-	-	385	1117	-
HCM Lane V/C Ratio	-	-	0.112	0.011	-
HCM Control Delay (s)	-	-	15.5	8.3	0
HCM Lane LOS	-	-	C	A	A
HCM 95th %tile Q(veh)	-	-	0.4	0	-

Intersection						
Int Delay, s/veh	1.5					
Movement	EBL	EBR	NBL	NBT	SBT	SBR
Lane Configurations	↙	↗	↙	↑↑	↑↑	
Traffic Vol, veh/h	21	60	77	614	633	31
Future Vol, veh/h	21	60	77	614	633	31
Conflicting Peds, #/hr	1	0	1	0	0	1
Sign Control	Stop	Stop	Free	Free	Free	Free
RT Channelized	-	None	-	None	-	None
Storage Length	125	0	0	-	-	-
Veh in Median Storage, #	0	-	-	0	0	-
Grade, %	0	-	-	0	0	-
Peak Hour Factor	92	92	92	92	92	92
Heavy Vehicles, %	5	5	6	6	3	3
Mvmt Flow	23	65	84	667	688	34

Major/Minor	Minor2	Major1	Major2			
Conflicting Flow All	1208	362	723	0	-	0
Stage 1	706	-	-	-	-	-
Stage 2	502	-	-	-	-	-
Critical Hdwy	6.9	7	4.22	-	-	-
Critical Hdwy Stg 1	5.9	-	-	-	-	-
Critical Hdwy Stg 2	5.9	-	-	-	-	-
Follow-up Hdwy	3.55	3.35	2.26	-	-	-
Pot Cap-1 Maneuver	171	626	849	-	-	-
Stage 1	443	-	-	-	-	-
Stage 2	565	-	-	-	-	-
Platoon blocked, %				-	-	-
Mov Cap-1 Maneuver	154	625	849	-	-	-
Mov Cap-2 Maneuver	154	-	-	-	-	-
Stage 1	443	-	-	-	-	-
Stage 2	509	-	-	-	-	-

Approach	EB	NB	SB
HCM Control Delay, s	16.8	1.1	0
HCM LOS	C		

Minor Lane/Major Mvmt	NBL	NBT	EBLn1	EBLn2	SBT	SBR
Capacity (veh/h)	849	-	154	625	-	-
HCM Lane V/C Ratio	0.099	-	0.148	0.104	-	-
HCM Control Delay (s)	9.7	-	32.4	11.4	-	-
HCM Lane LOS	A	-	D	B	-	-
HCM 95th %tile Q(veh)	0.3	-	0.5	0.3	-	-

Intersection						
Int Delay, s/veh	0.2					
Movement	EBL	EBT	WBT	WBR	SBL	SBR
Lane Configurations	↙	↑	↘		↙	↘
Traffic Vol, veh/h	2	528	783	7	7	1
Future Vol, veh/h	2	528	783	7	7	1
Conflicting Peds, #/hr	0	0	0	0	0	0
Sign Control	Free	Free	Free	Free	Stop	Stop
RT Channelized	-	None	-	None	-	None
Storage Length	125	-	-	-	75	0
Veh in Median Storage, #	-	0	0	-	0	-
Grade, %	-	0	0	-	0	-
Peak Hour Factor	95	95	95	95	95	95
Heavy Vehicles, %	2	2	2	2	28	2
Mvmt Flow	2	556	824	7	7	1

Major/Minor	Major1	Major2	Minor2		
Conflicting Flow All	832	0	-	0	1388 828
Stage 1	-	-	-	-	828 -
Stage 2	-	-	-	-	560 -
Critical Hdwy	4.12	-	-	-	6.68 6.22
Critical Hdwy Stg 1	-	-	-	-	5.68 -
Critical Hdwy Stg 2	-	-	-	-	5.68 -
Follow-up Hdwy	2.218	-	-	-	3.752 3.318
Pot Cap-1 Maneuver	801	-	-	-	138 371
Stage 1	-	-	-	-	388 -
Stage 2	-	-	-	-	523 -
Platoon blocked, %		-	-	-	
Mov Cap-1 Maneuver	801	-	-	-	138 371
Mov Cap-2 Maneuver	-	-	-	-	138 -
Stage 1	-	-	-	-	388 -
Stage 2	-	-	-	-	522 -

Approach	EB	WB	SB
HCM Control Delay, s	0	0	30.4
HCM LOS			D

Minor Lane/Major Mvmt	EBL	EBT	WBT	WBR	SBLn1	SBLn2
Capacity (veh/h)	801	-	-	-	138	371
HCM Lane V/C Ratio	0.003	-	-	-	0.053	0.003
HCM Control Delay (s)	9.5	-	-	-	32.6	14.7
HCM Lane LOS	A	-	-	-	D	B
HCM 95th %tile Q(veh)	0	-	-	-	0.2	0

HCM 2010 TWSC
 4: Estes Drive Extension & Airport Drive

12/13/2017

Intersection						
Int Delay, s/veh	7.1					
Movement	NWL	NWR	NET	NER	SWL	SWT
Lane Configurations	W		T			T
Traffic Vol, veh/h	110	40	502	36	6	689
Future Vol, veh/h	110	40	502	36	6	689
Conflicting Peds, #/hr	0	0	0	0	0	0
Sign Control	Stop	Stop	Free	Free	Free	Free
RT Channelized	-	None	-	None	-	None
Storage Length	0	-	-	-	-	-
Veh in Median Storage, #	0	-	0	-	-	0
Grade, %	0	-	0	-	-	0
Peak Hour Factor	93	93	93	93	93	93
Heavy Vehicles, %	5	4	2	6	2	2
Mvmt Flow	118	43	540	39	6	741

Major/Minor	Minor1	Major1	Major2
Conflicting Flow All	1313	559	0
Stage 1	559	-	-
Stage 2	754	-	-
Critical Hdwy	6.45	6.24	-
Critical Hdwy Stg 1	5.45	-	-
Critical Hdwy Stg 2	5.45	-	-
Follow-up Hdwy	3.545	3.336	-
Pot Cap-1 Maneuver	172	525	-
Stage 1	567	-	-
Stage 2	459	-	-
Platoon blocked, %		-	-
Mov Cap-1 Maneuver	170	525	-
Mov Cap-2 Maneuver	170	-	-
Stage 1	567	-	-
Stage 2	454	-	-

Approach	NW	NE	SW
HCM Control Delay, s	65.3	0	0.1
HCM LOS	F		

Minor Lane/Major Mvmt	NET	NERNWLn1	SWL	SWT
Capacity (veh/h)	-	-	207	996
HCM Lane V/C Ratio	-	-	0.779	0.006
HCM Control Delay (s)	-	-	65.3	8.6
HCM Lane LOS	-	-	F	A
HCM 95th %tile Q(veh)	-	-	5.4	0

Intersection						
Int Delay, s/veh	1.9					
Movement	EBL	EBR	NBL	NBT	SBT	SBR
Lane Configurations						
Traffic Vol, veh/h	37	46	45	1291	808	6
Future Vol, veh/h	37	46	45	1291	808	6
Conflicting Peds, #/hr	4	0	2	0	0	2
Sign Control	Stop	Stop	Free	Free	Free	Free
RT Channelized	-	None	-	None	-	None
Storage Length	125	0	0	-	-	-
Veh in Median Storage, #	0	-	-	0	0	-
Grade, %	0	-	-	0	0	-
Peak Hour Factor	94	94	94	94	94	94
Heavy Vehicles, %	6	6	7	2	2	2
Mvmt Flow	39	49	48	1373	860	6

Major/Minor	Minor2	Major1	Major2			
Conflicting Flow All	1651	435	868	0	-	0
Stage 1	865	-	-	-	-	-
Stage 2	786	-	-	-	-	-
Critical Hdwy	6.92	7.02	4.24	-	-	-
Critical Hdwy Stg 1	5.92	-	-	-	-	-
Critical Hdwy Stg 2	5.92	-	-	-	-	-
Follow-up Hdwy	3.56	3.36	2.27	-	-	-
Pot Cap-1 Maneuver	86	558	741	-	-	-
Stage 1	363	-	-	-	-	-
Stage 2	399	-	-	-	-	-
Platoon blocked, %				-	-	-
Mov Cap-1 Maneuver	80	557	741	-	-	-
Mov Cap-2 Maneuver	80	-	-	-	-	-
Stage 1	362	-	-	-	-	-
Stage 2	372	-	-	-	-	-

Approach	EB	NB	SB
HCM Control Delay, s	45.7	0.3	0
HCM LOS	E		

Minor Lane/Major Mvmt	NBL	NBT	EBLn1	EBLn2	SBT	SBR
Capacity (veh/h)	741	-	80	557	-	-
HCM Lane V/C Ratio	0.065	-	0.492	0.088	-	-
HCM Control Delay (s)	10.2	-	87.5	12.1	-	-
HCM Lane LOS	B	-	F	B	-	-
HCM 95th %tile Q(veh)	0.2	-	2.1	0.3	-	-

Intersection

Int Delay, s/veh 0.4

Movement	EBL	EBT	EBR	WBL	WBT	WBR	NBL	NBT	NBR	SBL	SBT	SBR
Lane Configurations	↖	↗		↖	↗			↕		↖	↗	
Traffic Vol, veh/h	1	862	6	19	355	8	1	0	2	5	0	0
Future Vol, veh/h	1	862	6	19	355	8	1	0	2	5	0	0
Conflicting Peds, #/hr	0	0	0	0	0	0	0	0	0	0	0	0
Sign Control	Free	Free	Free	Free	Free	Free	Stop	Stop	Stop	Stop	Stop	Stop
RT Channelized	-	-	None	-	-	None	-	-	None	-	-	None
Storage Length	125	-	-	100	-	-	-	-	-	75	-	-
Veh in Median Storage, #	-	0	-	-	0	-	-	0	-	-	0	-
Grade, %	-	0	-	-	0	-	-	0	-	-	0	-
Peak Hour Factor	90	90	90	90	90	90	90	90	90	90	90	90
Heavy Vehicles, %	2	2	2	2	7	7	2	2	2	40	2	2
Mvmt Flow	1	958	7	21	394	9	1	0	2	6	0	0

Major/Minor	Major1	Major2	Minor1	Minor2
Conflicting Flow All	403	0	0	964
Stage 1	-	-	-	-
Stage 2	-	-	-	-
Critical Hdwy	4.12	-	-	4.12
Critical Hdwy Stg 1	-	-	-	-
Critical Hdwy Stg 2	-	-	-	-
Follow-up Hdwy	2.218	-	-	2.218
Pot Cap-1 Maneuver	1156	-	-	714
Stage 1	-	-	-	-
Stage 2	-	-	-	-
Platoon blocked, %	-	-	-	-
Mov Cap-1 Maneuver	1156	-	-	714
Mov Cap-2 Maneuver	-	-	-	-
Stage 1	-	-	-	-
Stage 2	-	-	-	-

Approach	EB	WB	NB	SB
HCM Control Delay, s	0	0.5	23.6	45.7
HCM LOS			C	E

Minor Lane/Major Mvmt	NBLn1	EBL	EBT	EBR	WBL	WBT	WBR	SBLn1	SBLn2
Capacity (veh/h)	197	1156	-	-	714	-	-	94	-
HCM Lane V/C Ratio	0.017	0.001	-	-	0.03	-	-	0.059	-
HCM Control Delay (s)	23.6	8.1	-	-	10.2	-	-	45.7	0
HCM Lane LOS	C	A	-	-	B	-	-	E	A
HCM 95th %tile Q(veh)	0.1	0	-	-	0.1	-	-	0.2	-

Intersection						
Int Delay, s/veh	0.9					
Movement	NBL	NBR	NET	NER	SWL	SWT
Lane Configurations	↖	↗	↖		↖	↗
Traffic Vol, veh/h	1	12	863	6	95	379
Future Vol, veh/h	1	12	863	6	95	379
Conflicting Peds, #/hr	0	0	0	0	0	0
Sign Control	Stop	Stop	Free	Free	Free	Free
RT Channelized	-	None	-	None	-	None
Storage Length	50	0	-	-	100	-
Veh in Median Storage, #	0	-	0	-	-	0
Grade, %	0	-	0	-	-	0
Peak Hour Factor	90	90	90	90	90	90
Heavy Vehicles, %	2	2	2	2	2	2
Mvmt Flow	1	13	959	7	106	421

Major/Minor	Minor1	Major1	Major2			
Conflicting Flow All	1594	962	0	0	966	0
Stage 1	962	-	-	-	-	-
Stage 2	632	-	-	-	-	-
Critical Hdwy	6.42	6.22	-	-	4.12	-
Critical Hdwy Stg 1	5.42	-	-	-	-	-
Critical Hdwy Stg 2	5.42	-	-	-	-	-
Follow-up Hdwy	3.518	3.318	-	-	2.218	-
Pot Cap-1 Maneuver	118	310	-	-	713	-
Stage 1	371	-	-	-	-	-
Stage 2	530	-	-	-	-	-
Platoon blocked, %			-	-		
Mov Cap-1 Maneuver	100	310	-	-	713	-
Mov Cap-2 Maneuver	231	-	-	-	-	-
Stage 1	371	-	-	-	-	-
Stage 2	451	-	-	-	-	-

Approach	NB	NE	SW
HCM Control Delay, s	17.4	0	2.2
HCM LOS	C		

Minor Lane/Major Mvmt	NET	NER	NBLn1	NBLn2	SWL	SWT
Capacity (veh/h)	-	-	231	310	713	-
HCM Lane V/C Ratio	-	-	0.005	0.043	0.148	-
HCM Control Delay (s)	-	-	20.7	17.1	10.9	-
HCM Lane LOS	-	-	C	C	B	-
HCM 95th %tile Q(veh)	-	-	0	0.1	0.5	-

HCM 2010 TWSC
 4: Estes Drive Extension & Airport Drive

12/21/2017

Intersection						
Int Delay, s/veh	1.3					
Movement	NWL	NWR	NET	NER	SWL	SWT
Lane Configurations						
Traffic Vol, veh/h	51	22	787	95	12	422
Future Vol, veh/h	51	22	787	95	12	422
Conflicting Peds, #/hr	0	0	0	0	0	0
Sign Control	Stop	Stop	Free	Free	Free	Free
RT Channelized	-	None	-	None	-	None
Storage Length	0	-	-	-	100	-
Veh in Median Storage, #	0	-	0	-	-	0
Grade, %	0	-	0	-	-	0
Peak Hour Factor	91	91	91	91	91	91
Heavy Vehicles, %	8	14	2	2	17	7
Mvmt Flow	56	24	865	104	13	464

Major/Minor	Minor1	Major1	Major2		
Conflicting Flow All	1407	917	0	0	969
Stage 1	917	-	-	-	-
Stage 2	490	-	-	-	-
Critical Hdwy	6.48	6.34	-	-	4.27
Critical Hdwy Stg 1	5.48	-	-	-	-
Critical Hdwy Stg 2	5.48	-	-	-	-
Follow-up Hdwy	3.572	3.426	-	-	2.353
Pot Cap-1 Maneuver	149	313	-	-	654
Stage 1	380	-	-	-	-
Stage 2	604	-	-	-	-
Platoon blocked, %			-	-	-
Mov Cap-1 Maneuver	146	313	-	-	654
Mov Cap-2 Maneuver	273	-	-	-	-
Stage 1	380	-	-	-	-
Stage 2	592	-	-	-	-

Approach	NW	NE	SW
HCM Control Delay, s	22.6	0	0.3
HCM LOS	C		

Minor Lane/Major Mvmt	NET	NERNWLn1	SWL	SWT
Capacity (veh/h)	-	-	284	654
HCM Lane V/C Ratio	-	-	0.282	0.02
HCM Control Delay (s)	-	-	22.6	10.6
HCM Lane LOS	-	-	C	B
HCM 95th %tile Q(veh)	-	-	1.1	0.1

Intersection												
Int Delay, s/veh	0.5											
Movement	EBL	EBT	EBR	WBL	WBT	WBR	NBL	NBT	NBR	SBL	SBT	SBR
Lane Configurations	↖	↗		↖	↗			↔		↖	↗	
Traffic Vol, veh/h	4	425	4	13	414	8	4	0	13	4	0	0
Future Vol, veh/h	4	425	4	13	414	8	4	0	13	4	0	0
Conflicting Peds, #/hr	0	0	0	0	0	0	0	0	0	0	0	0
Sign Control	Free	Free	Free	Free	Free	Free	Stop	Stop	Stop	Stop	Stop	Stop
RT Channelized	-	-	None	-	-	None	-	-	None	-	-	None
Storage Length	125	-	-	100	-	-	-	-	-	75	-	-
Veh in Median Storage, #	-	0	-	-	0	-	-	0	-	-	0	-
Grade, %	-	0	-	-	0	-	-	0	-	-	0	-
Peak Hour Factor	90	90	90	90	90	90	90	90	90	90	90	90
Heavy Vehicles, %	3	3	2	2	4	4	2	2	2	2	2	2
Mvmt Flow	4	472	4	14	460	9	4	0	14	4	0	0

Major/Minor	Major1			Major2			Minor1			Minor2		
Conflicting Flow All	469	0	0	477	0	0	976	981	474	984	979	464
Stage 1	-	-	-	-	-	-	483	483	-	493	493	-
Stage 2	-	-	-	-	-	-	493	498	-	491	486	-
Critical Hdwy	4.13	-	-	4.12	-	-	7.12	6.52	6.22	7.12	6.52	6.22
Critical Hdwy Stg 1	-	-	-	-	-	-	6.12	5.52	-	6.12	5.52	-
Critical Hdwy Stg 2	-	-	-	-	-	-	6.12	5.52	-	6.12	5.52	-
Follow-up Hdwy	2.227	-	-	2.218	-	-	3.518	4.018	3.318	3.518	4.018	3.318
Pot Cap-1 Maneuver	1087	-	-	1085	-	-	230	249	590	228	250	598
Stage 1	-	-	-	-	-	-	565	553	-	558	547	-
Stage 2	-	-	-	-	-	-	558	544	-	559	551	-
Platoon blocked, %	-	-	-	-	-	-	-	-	-	-	-	-
Mov Cap-1 Maneuver	1087	-	-	1085	-	-	227	245	590	220	246	598
Mov Cap-2 Maneuver	-	-	-	-	-	-	227	245	-	220	246	-
Stage 1	-	-	-	-	-	-	563	551	-	556	540	-
Stage 2	-	-	-	-	-	-	551	537	-	543	549	-

Approach	EB			WB			NB			SB		
HCM Control Delay, s	0.1			0.2			13.8			21.7		
HCM LOS							B			C		

Minor Lane/Major Mvmt	NBLn1	EBL	EBT	EBR	WBL	WBT	WBR	SBLn1	SBLn2
Capacity (veh/h)	429	1087	-	-	1085	-	-	220	-
HCM Lane V/C Ratio	0.044	0.004	-	-	0.013	-	-	0.02	-
HCM Control Delay (s)	13.8	8.3	-	-	8.4	-	-	21.7	0
HCM Lane LOS	B	A	-	-	A	-	-	C	A
HCM 95th %tile Q(veh)	0.1	0	-	-	0	-	-	0.1	-

HCM 2010 TWSC
 3: Estes Drive Extension & East Site Driveway

12/21/2017

Intersection						
Int Delay, s/veh	1.4					
Movement	NBL	NBR	NET	NER	SWL	SWT
Lane Configurations	↙	↗	↔		↙	↗
Traffic Vol, veh/h	4	63	434	4	65	440
Future Vol, veh/h	4	63	434	4	65	440
Conflicting Peds, #/hr	0	0	0	0	0	0
Sign Control	Stop	Stop	Free	Free	Free	Free
RT Channelized	-	None	-	None	-	None
Storage Length	0	0	-	-	100	-
Veh in Median Storage, #	0	-	0	-	-	0
Grade, %	0	-	0	-	-	0
Peak Hour Factor	90	90	90	90	90	90
Heavy Vehicles, %	2	2	2	2	2	2
Mvmt Flow	4	70	482	4	72	489

Major/Minor	Minor1	Major1	Major2		
Conflicting Flow All	1117	484	0	0	487
Stage 1	484	-	-	-	-
Stage 2	633	-	-	-	-
Critical Hdwy	6.42	6.22	-	-	4.12
Critical Hdwy Stg 1	5.42	-	-	-	-
Critical Hdwy Stg 2	5.42	-	-	-	-
Follow-up Hdwy	3.518	3.318	-	-	2.218
Pot Cap-1 Maneuver	229	583	-	-	1076
Stage 1	620	-	-	-	-
Stage 2	529	-	-	-	-
Platoon blocked, %			-	-	-
Mov Cap-1 Maneuver	214	583	-	-	1076
Mov Cap-2 Maneuver	347	-	-	-	-
Stage 1	620	-	-	-	-
Stage 2	494	-	-	-	-

Approach	NB	NE	SW
HCM Control Delay, s	12.2	0	1.1
HCM LOS	B		

Minor Lane/Major Mvmt	NET	NER	NBLn1	NBLn2	SWL	SWT
Capacity (veh/h)	-	-	347	583	1076	-
HCM Lane V/C Ratio	-	-	0.013	0.12	0.067	-
HCM Control Delay (s)	-	-	15.5	12	8.6	-
HCM Lane LOS	-	-	C	B	A	-
HCM 95th %tile Q(veh)	-	-	0	0.4	0.2	-

HCM 2010 TWSC
4: Estes Drive Extension & Airport Drive

12/21/2017

Intersection						
Int Delay, s/veh	0.9					
Movement	NWL	NWR	NET	NER	SWL	SWT
Lane Configurations						
Traffic Vol, veh/h	40	18	440	57	12	465
Future Vol, veh/h	40	18	440	57	12	465
Conflicting Peds, #/hr	0	0	0	0	0	0
Sign Control	Stop	Stop	Free	Free	Free	Free
RT Channelized	-	None	-	None	-	None
Storage Length	0	-	-	-	100	-
Veh in Median Storage, #	0	-	0	-	-	0
Grade, %	0	-	0	-	-	0
Peak Hour Factor	95	95	95	95	95	95
Heavy Vehicles, %	18	6	2	8	2	3
Mvmt Flow	42	19	463	60	13	489

Major/Minor	Minor1	Major1	Major2		
Conflicting Flow All	1008	493	0	0	523
Stage 1	493	-	-	-	-
Stage 2	515	-	-	-	-
Critical Hdwy	6.58	6.26	-	-	4.12
Critical Hdwy Stg 1	5.58	-	-	-	-
Critical Hdwy Stg 2	5.58	-	-	-	-
Follow-up Hdwy	3.662	3.354	-	-	2.218
Pot Cap-1 Maneuver	249	568	-	-	1043
Stage 1	582	-	-	-	-
Stage 2	568	-	-	-	-
Platoon blocked, %					
Mov Cap-1 Maneuver	246	568	-	-	1043
Mov Cap-2 Maneuver	373	-	-	-	-
Stage 1	582	-	-	-	-
Stage 2	561	-	-	-	-

Approach	NW	NE	SW
HCM Control Delay, s	15.1	0	0.2
HCM LOS	C		

Minor Lane/Major Mvmt	NET	NERNWLn1	SWL	SWT
Capacity (veh/h)	-	-	417	1043
HCM Lane V/C Ratio	-	-	0.146	0.012
HCM Control Delay (s)	-	-	15.1	8.5
HCM Lane LOS	-	-	C	A
HCM 95th %tile Q(veh)	-	-	0.5	0

Intersection

Int Delay, s/veh 0.8

Movement	EBL	EBT	EBR	WBL	WBT	WBR	NBL	NBT	NBR	SBL	SBT	SBR
Lane Configurations	↖	↗		↖	↗			↔		↖	↗	
Traffic Vol, veh/h	2	530	2	6	791	7	8	0	23	7	0	1
Future Vol, veh/h	2	530	2	6	791	7	8	0	23	7	0	1
Conflicting Peds, #/hr	0	0	0	0	0	0	0	0	0	0	0	0
Sign Control	Free	Free	Free	Free	Free	Free	Stop	Stop	Stop	Stop	Stop	Stop
RT Channelized	-	-	None	-	-	None	-	-	None	-	-	None
Storage Length	125	-	-	0	-	-	-	-	-	75	-	-
Veh in Median Storage, #	-	0	-	-	0	-	-	0	-	-	0	-
Grade, %	-	0	-	-	0	-	-	0	-	-	0	-
Peak Hour Factor	95	95	90	90	95	95	90	90	90	95	90	95
Heavy Vehicles, %	2	2	2	2	2	2	2	2	2	28	2	2
Mvmt Flow	2	558	2	7	833	7	9	0	26	7	0	1

Major/Minor	Major1	Major2	Minor1	Minor2
Conflicting Flow All	840	0	0	560
Stage 1	-	-	-	-
Stage 2	-	-	-	-
Critical Hdwy	4.12	-	-	4.12
Critical Hdwy Stg 1	-	-	-	-
Critical Hdwy Stg 2	-	-	-	-
Follow-up Hdwy	2.218	-	-	2.218
Pot Cap-1 Maneuver	795	-	-	1011
Stage 1	-	-	-	-
Stage 2	-	-	-	-
Platoon blocked, %	-	-	-	-
Mov Cap-1 Maneuver	795	-	-	1011
Mov Cap-2 Maneuver	-	-	-	-
Stage 1	-	-	-	-
Stage 2	-	-	-	-

Approach	EB	WB	NB	SB
HCM Control Delay, s	0	0.1	20.1	42.5
HCM LOS			C	E

Minor Lane/Major Mvmt	NBLn1	EBL	EBT	EBR	WBL	WBT	WBR	SBLn1	SBLn2
Capacity (veh/h)	273	795	-	-	1011	-	-	94	367
HCM Lane V/C Ratio	0.126	0.003	-	-	0.007	-	-	0.078	0.003
HCM Control Delay (s)	20.1	9.5	-	-	8.6	-	-	46.5	14.8
HCM Lane LOS	C	A	-	-	A	-	-	E	B
HCM 95th %tile Q(veh)	0.4	0	-	-	0	-	-	0.2	0

HCM 2010 TWSC
 3: Estes Drive Extension & East Site Driveway

12/21/2017

Intersection						
Int Delay, s/veh	1.4					
Movement	NBL	NBR	NET	NER	SWL	SWT
Lane Configurations	↘	↗	↔		↘	↗
Traffic Vol, veh/h	8	113	558	2	29	806
Future Vol, veh/h	8	113	558	2	29	806
Conflicting Peds, #/hr	0	0	0	0	0	0
Sign Control	Stop	Stop	Free	Free	Free	Free
RT Channelized	-	None	-	None	-	None
Storage Length	50	0	-	-	200	-
Veh in Median Storage, #	0	-	0	-	-	0
Grade, %	0	-	0	-	-	0
Peak Hour Factor	90	90	90	90	90	90
Heavy Vehicles, %	2	2	2	2	2	2
Mvmt Flow	9	126	620	2	32	896

Major/Minor	Minor1	Major1	Major2		
Conflicting Flow All	1581	621	0	0	622
Stage 1	621	-	-	-	-
Stage 2	960	-	-	-	-
Critical Hdwy	6.42	6.22	-	-	4.12
Critical Hdwy Stg 1	5.42	-	-	-	-
Critical Hdwy Stg 2	5.42	-	-	-	-
Follow-up Hdwy	3.518	3.318	-	-	2.218
Pot Cap-1 Maneuver	120	487	-	-	959
Stage 1	536	-	-	-	-
Stage 2	372	-	-	-	-
Platoon blocked, %					
Mov Cap-1 Maneuver	116	487	-	-	959
Mov Cap-2 Maneuver	247	-	-	-	-
Stage 1	536	-	-	-	-
Stage 2	360	-	-	-	-

Approach	NB	NE	SW
HCM Control Delay, s	15.2	0	0.3
HCM LOS	C		

Minor Lane/Major Mvmt	NET	NER	NBLn1	NBLn2	SWL	SWT
Capacity (veh/h)	-	-	247	487	959	-
HCM Lane V/C Ratio	-	-	0.036	0.258	0.034	-
HCM Control Delay (s)	-	-	20.1	14.9	8.9	-
HCM Lane LOS	-	-	C	B	A	-
HCM 95th %tile Q(veh)	-	-	0.1	1	0.1	-

Intersection						
Int Delay, s/veh	3.2					
Movement	NWL	NWR	NET	NER	SWL	SWT
Lane Configurations						
Traffic Vol, veh/h	118	40	607	66	6	716
Future Vol, veh/h	118	40	607	66	6	716
Conflicting Peds, #/hr	0	0	0	0	0	0
Sign Control	Stop	Stop	Free	Free	Free	Free
RT Channelized	-	None	-	None	-	None
Storage Length	0	-	-	-	200	-
Veh in Median Storage, #	0	-	0	-	-	0
Grade, %	0	-	0	-	-	0
Peak Hour Factor	93	93	93	93	93	93
Heavy Vehicles, %	5	4	2	6	2	2
Mvmt Flow	127	43	653	71	6	770

Major/Minor	Minor1	Major1	Major2		
Conflicting Flow All	1471	688	0	0	724
Stage 1	688	-	-	-	-
Stage 2	783	-	-	-	-
Critical Hdwy	6.45	6.24	-	-	4.12
Critical Hdwy Stg 1	5.45	-	-	-	-
Critical Hdwy Stg 2	5.45	-	-	-	-
Follow-up Hdwy	3.545	3.336	-	-	2.218
Pot Cap-1 Maneuver	138	443	-	-	879
Stage 1	493	-	-	-	-
Stage 2	445	-	-	-	-
Platoon blocked, %					
Mov Cap-1 Maneuver	137	443	-	-	879
Mov Cap-2 Maneuver	275	-	-	-	-
Stage 1	493	-	-	-	-
Stage 2	442	-	-	-	-

Approach	NW	NE	SW
HCM Control Delay, s	30.9	0	0.1
HCM LOS	D		

Minor Lane/Major Mvmt	NET	NERNWLn1	SWL	SWT
Capacity (veh/h)	-	-	304	879
HCM Lane V/C Ratio	-	-	0.559	0.007
HCM Control Delay (s)	-	-	30.9	9.1
HCM Lane LOS	-	-	D	A
HCM 95th %tile Q(veh)	-	-	3.2	0

Intersection												
Int Delay, s/veh	0.4											
Movement	EBL	EBT	EBR	WBL	WBT	WBR	NBL	NBT	NBR	SBL	SBT	SBR
Lane Configurations	↖	↗			↕			↕		↖	↗	
Traffic Vol, veh/h	1	862	6	19	355	8	1	0	2	5	0	0
Future Vol, veh/h	1	862	6	19	355	8	1	0	2	5	0	0
Conflicting Peds, #/hr	0	0	0	0	0	0	0	0	0	0	0	0
Sign Control	Free	Free	Free	Free	Free	Free	Stop	Stop	Stop	Stop	Stop	Stop
RT Channelized	-	-	None	-	-	None	-	-	None	-	-	None
Storage Length	125	-	-	-	-	-	-	-	-	75	-	-
Veh in Median Storage, #	-	0	-	-	0	-	-	0	-	-	0	-
Grade, %	-	0	-	-	0	-	-	0	-	-	0	-
Peak Hour Factor	90	90	90	90	90	90	90	90	90	90	90	90
Heavy Vehicles, %	2	2	2	2	7	7	2	2	2	40	2	2
Mvmt Flow	1	958	7	21	394	9	1	0	2	6	0	0

Major/Minor	Major1			Major2			Minor1			Minor2		
Conflicting Flow All	403	0	0	964	0	0	1404	1409	961	1405	1408	399
Stage 1	-	-	-	-	-	-	963	963	-	441	441	-
Stage 2	-	-	-	-	-	-	441	446	-	964	967	-
Critical Hdwy	4.12	-	-	4.12	-	-	7.12	6.52	6.22	7.5	6.52	6.22
Critical Hdwy Stg 1	-	-	-	-	-	-	6.12	5.52	-	6.5	5.52	-
Critical Hdwy Stg 2	-	-	-	-	-	-	6.12	5.52	-	6.5	5.52	-
Follow-up Hdwy	2.218	-	-	2.218	-	-	3.518	4.018	3.318	3.86	4.018	3.318
Pot Cap-1 Maneuver	1156	-	-	714	-	-	117	139	311	97	139	651
Stage 1	-	-	-	-	-	-	307	334	-	528	577	-
Stage 2	-	-	-	-	-	-	595	574	-	262	333	-
Platoon blocked, %	-	-	-	-	-	-	-	-	-	-	-	-
Mov Cap-1 Maneuver	1156	-	-	714	-	-	114	134	311	93	134	651
Mov Cap-2 Maneuver	-	-	-	-	-	-	114	134	-	93	134	-
Stage 1	-	-	-	-	-	-	307	334	-	528	555	-
Stage 2	-	-	-	-	-	-	572	552	-	260	333	-

Approach	EB			WB			NB			SB		
HCM Control Delay, s	0			0.5			23.6			46.2		
HCM LOS							C			E		

Minor Lane/Major Mvmt	NBLn1	EBL	EBT	EBR	WBL	WBT	WBR	SBLn1	SBLn2
Capacity (veh/h)	197	1156	-	-	714	-	-	93	-
HCM Lane V/C Ratio	0.017	0.001	-	-	0.03	-	-	0.06	-
HCM Control Delay (s)	23.6	8.1	-	-	10.2	0	-	46.2	0
HCM Lane LOS	C	A	-	-	B	A	-	E	A
HCM 95th %tile Q(veh)	0.1	0	-	-	0.1	-	-	0.2	-

Intersection						
Int Delay, s/veh	1					
Movement	NBL	NBR	NET	NER	SWL	SWT
Lane Configurations						
Traffic Vol, veh/h	1	12	863	6	95	379
Future Vol, veh/h	1	12	863	6	95	379
Conflicting Peds, #/hr	0	0	0	0	0	0
Sign Control	Stop	Stop	Free	Free	Free	Free
RT Channelized	-	None	-	None	-	None
Storage Length	50	0	-	-	-	-
Veh in Median Storage, #	0	-	0	-	-	0
Grade, %	0	-	0	-	-	0
Peak Hour Factor	90	90	90	90	90	90
Heavy Vehicles, %	2	2	2	2	2	2
Mvmt Flow	1	13	959	7	106	421

Major/Minor	Minor1	Major1	Major2			
Conflicting Flow All	1594	962	0	0	966	0
Stage 1	962	-	-	-	-	-
Stage 2	632	-	-	-	-	-
Critical Hdwy	6.42	6.22	-	-	4.12	-
Critical Hdwy Stg 1	5.42	-	-	-	-	-
Critical Hdwy Stg 2	5.42	-	-	-	-	-
Follow-up Hdwy	3.518	3.318	-	-	2.218	-
Pot Cap-1 Maneuver	118	310	-	-	713	-
Stage 1	371	-	-	-	-	-
Stage 2	530	-	-	-	-	-
Platoon blocked, %			-	-		
Mov Cap-1 Maneuver	95	310	-	-	713	-
Mov Cap-2 Maneuver	95	-	-	-	-	-
Stage 1	371	-	-	-	-	-
Stage 2	427	-	-	-	-	-

Approach	NB	NE	SW
HCM Control Delay, s	19.1	0	2.2
HCM LOS	C		

Minor Lane/Major Mvmt	NET	NER	NBLn1	NBLn2	SWL	SWT
Capacity (veh/h)	-	-	95	310	713	-
HCM Lane V/C Ratio	-	-	0.012	0.043	0.148	-
HCM Control Delay (s)	-	-	43.3	17.1	10.9	0
HCM Lane LOS	-	-	E	C	B	A
HCM 95th %tile Q(veh)	-	-	0	0.1	0.5	-

Intersection						
Int Delay, s/veh	2.3					
Movement	NWL	NWR	NET	NER	SWL	SWT
Lane Configurations						
Traffic Vol, veh/h	51	22	787	95	12	422
Future Vol, veh/h	51	22	787	95	12	422
Conflicting Peds, #/hr	0	0	0	0	0	0
Sign Control	Stop	Stop	Free	Free	Free	Free
RT Channelized	-	None	-	None	-	None
Storage Length	0	-	-	-	-	-
Veh in Median Storage, #	0	-	0	-	-	0
Grade, %	0	-	0	-	-	0
Peak Hour Factor	91	91	91	91	91	91
Heavy Vehicles, %	8	14	2	2	17	7
Mvmt Flow	56	24	865	104	13	464

Major/Minor	Minor1	Major1	Major2
Conflicting Flow All	1407	917	0
Stage 1	917	-	-
Stage 2	490	-	-
Critical Hdwy	6.48	6.34	-
Critical Hdwy Stg 1	5.48	-	-
Critical Hdwy Stg 2	5.48	-	-
Follow-up Hdwy	3.572	3.426	-
Pot Cap-1 Maneuver	149	313	-
Stage 1	380	-	-
Stage 2	604	-	-
Platoon blocked, %		-	-
Mov Cap-1 Maneuver	145	313	-
Mov Cap-2 Maneuver	145	-	-
Stage 1	380	-	-
Stage 2	588	-	-

Approach	NW	NE	SW
HCM Control Delay, s	42.6	0	0.3
HCM LOS	E		

Minor Lane/Major Mvmt	NET	NERNWLn1	SWL	SWT
Capacity (veh/h)	-	-	173	654
HCM Lane V/C Ratio	-	-	0.464	0.02
HCM Control Delay (s)	-	-	42.6	10.6
HCM Lane LOS	-	-	E	B
HCM 95th %tile Q(veh)	-	-	2.2	0.1

Intersection						
Int Delay, s/veh	1.8					
Movement	EBL	EBR	NBL	NBT	SBT	SBR
Lane Configurations						
Traffic Vol, veh/h	3	99	105	580	1128	135
Future Vol, veh/h	3	99	105	580	1128	135
Conflicting Peds, #/hr	10	0	1	0	0	1
Sign Control	Stop	Stop	Free	Free	Free	Free
RT Channelized	-	None	-	None	-	None
Storage Length	125	0	0	-	-	-
Veh in Median Storage, #	0	-	-	0	0	-
Grade, %	0	-	-	0	0	-
Peak Hour Factor	93	93	93	93	93	93
Heavy Vehicles, %	6	6	6	6	3	3
Mvmt Flow	3	106	113	624	1213	145

Major/Minor	Minor2	Major1	Major2			
Conflicting Flow All	1834	680	1359	0	-	0
Stage 1	1286	-	-	-	-	-
Stage 2	548	-	-	-	-	-
Critical Hdwy	6.92	7.02	4.22	-	-	-
Critical Hdwy Stg 1	5.92	-	-	-	-	-
Critical Hdwy Stg 2	5.92	-	-	-	-	-
Follow-up Hdwy	3.56	3.36	2.26	-	-	-
Pot Cap-1 Maneuver	65	384	481	-	-	-
Stage 1	216	-	-	-	-	-
Stage 2	532	-	-	-	-	-
Platoon blocked, %				-	-	-
Mov Cap-1 Maneuver	50	384	481	-	-	-
Mov Cap-2 Maneuver	50	-	-	-	-	-
Stage 1	216	-	-	-	-	-
Stage 2	407	-	-	-	-	-

Approach	EB	NB	SB
HCM Control Delay, s	19.8	2.3	0
HCM LOS	C		

Minor Lane/Major Mvmt	NBL	NBT	EBLn1	EBLn2	SBT	SBR
Capacity (veh/h)	481	-	50	384	-	-
HCM Lane V/C Ratio	0.235	-	0.065	0.277	-	-
HCM Control Delay (s)	14.8	-	81.9	17.9	-	-
HCM Lane LOS	B	-	F	C	-	-
HCM 95th %tile Q(veh)	0.9	-	0.2	1.1	-	-

Intersection												
Int Delay, s/veh	0.5											
Movement	EBL	EBT	EBR	WBL	WBT	WBR	NBL	NBT	NBR	SBL	SBT	SBR
Lane Configurations												
Traffic Vol, veh/h	4	425	4	13	414	8	4	0	13	4	0	0
Future Vol, veh/h	4	425	4	13	414	8	4	0	13	4	0	0
Conflicting Peds, #/hr	0	0	0	0	0	0	0	0	0	0	0	0
Sign Control	Free	Free	Free	Free	Free	Free	Stop	Stop	Stop	Stop	Stop	Stop
RT Channelized	-	-	None	-	-	None	-	-	None	-	-	None
Storage Length	125	-	-	-	-	-	-	-	-	75	-	-
Veh in Median Storage, #	-	0	-	-	0	-	-	0	-	-	0	-
Grade, %	-	0	-	-	0	-	-	0	-	-	0	-
Peak Hour Factor	90	90	90	90	90	90	90	90	90	90	90	90
Heavy Vehicles, %	3	3	2	2	4	4	2	2	2	2	2	2
Mvmt Flow	4	472	4	14	460	9	4	0	14	4	0	0

Major/Minor	Major1			Major2			Minor1			Minor2		
Conflicting Flow All	469	0	0	477	0	0	976	981	474	984	979	464
Stage 1	-	-	-	-	-	-	483	483	-	493	493	-
Stage 2	-	-	-	-	-	-	493	498	-	491	486	-
Critical Hdwy	4.13	-	-	4.12	-	-	7.12	6.52	6.22	7.12	6.52	6.22
Critical Hdwy Stg 1	-	-	-	-	-	-	6.12	5.52	-	6.12	5.52	-
Critical Hdwy Stg 2	-	-	-	-	-	-	6.12	5.52	-	6.12	5.52	-
Follow-up Hdwy	2.227	-	-	2.218	-	-	3.518	4.018	3.318	3.518	4.018	3.318
Pot Cap-1 Maneuver	1087	-	-	1085	-	-	230	249	590	228	250	598
Stage 1	-	-	-	-	-	-	565	553	-	558	547	-
Stage 2	-	-	-	-	-	-	558	544	-	559	551	-
Platoon blocked, %	-	-	-	-	-	-	-	-	-	-	-	-
Mov Cap-1 Maneuver	1087	-	-	1085	-	-	226	244	590	219	245	598
Mov Cap-2 Maneuver	-	-	-	-	-	-	226	244	-	219	245	-
Stage 1	-	-	-	-	-	-	563	551	-	556	538	-
Stage 2	-	-	-	-	-	-	549	535	-	543	549	-

Approach	EB			WB			NB			SB		
HCM Control Delay, s	0.1			0.2			13.8			21.8		
HCM LOS							B			C		

Minor Lane/Major Mvmt	NBLn1	EBL	EBT	EBR	WBL	WBT	WBR	SBLn1	SBLn2
Capacity (veh/h)	428	1087	-	-	1085	-	-	219	-
HCM Lane V/C Ratio	0.044	0.004	-	-	0.013	-	-	0.02	-
HCM Control Delay (s)	13.8	8.3	-	-	8.4	0	-	21.8	0
HCM Lane LOS	B	A	-	-	A	A	-	C	A
HCM 95th %tile Q(veh)	0.1	0	-	-	0	-	-	0.1	-

HCM 2010 TWSC
 3: Estes Drive Extension & East Site Driveway

12/13/2017

Intersection						
Int Delay, s/veh	1.4					
Movement	NBL	NBR	NET	NER	SWL	SWT
Lane Configurations						
Traffic Vol, veh/h	4	63	434	4	65	440
Future Vol, veh/h	4	63	434	4	65	440
Conflicting Peds, #/hr	0	0	0	0	0	0
Sign Control	Stop	Stop	Free	Free	Free	Free
RT Channelized	-	None	-	None	-	None
Storage Length	0	0	-	-	-	-
Veh in Median Storage, #	0	-	0	-	-	0
Grade, %	0	-	0	-	-	0
Peak Hour Factor	90	90	90	90	90	90
Heavy Vehicles, %	2	2	2	2	2	2
Mvmt Flow	4	70	482	4	72	489

Major/Minor	Minor1	Major1	Major2		
Conflicting Flow All	1117	484	0	0	487
Stage 1	484	-	-	-	-
Stage 2	633	-	-	-	-
Critical Hdwy	6.42	6.22	-	-	4.12
Critical Hdwy Stg 1	5.42	-	-	-	-
Critical Hdwy Stg 2	5.42	-	-	-	-
Follow-up Hdwy	3.518	3.318	-	-	2.218
Pot Cap-1 Maneuver	229	583	-	-	1076
Stage 1	620	-	-	-	-
Stage 2	529	-	-	-	-
Platoon blocked, %			-	-	-
Mov Cap-1 Maneuver	208	583	-	-	1076
Mov Cap-2 Maneuver	208	-	-	-	-
Stage 1	620	-	-	-	-
Stage 2	480	-	-	-	-

Approach	NB	NE	SW
HCM Control Delay, s	12.6	0	1.1
HCM LOS	B		

Minor Lane/Major Mvmt	NET	NER	NBLn1	NBLn2	SWL	SWT
Capacity (veh/h)	-	-	208	583	1076	-
HCM Lane V/C Ratio	-	-	0.021	0.12	0.067	-
HCM Control Delay (s)	-	-	22.7	12	8.6	0
HCM Lane LOS	-	-	C	B	A	A
HCM 95th %tile Q(veh)	-	-	0.1	0.4	0.2	-

HCM 2010 TWSC
 4: Estes Drive Extension & Airport Drive

12/13/2017

Intersection						
Int Delay, s/veh	1.2					
Movement	NWL	NWR	NET	NER	SWL	SWT
Lane Configurations						
Traffic Vol, veh/h	40	18	440	57	12	465
Future Vol, veh/h	40	18	440	57	12	465
Conflicting Peds, #/hr	0	0	0	0	0	0
Sign Control	Stop	Stop	Free	Free	Free	Free
RT Channelized	-	None	-	None	-	None
Storage Length	0	-	-	-	-	-
Veh in Median Storage, #	0	-	0	-	-	0
Grade, %	0	-	0	-	-	0
Peak Hour Factor	95	95	95	95	95	95
Heavy Vehicles, %	18	6	2	8	2	3
Mvmt Flow	42	19	463	60	13	489

Major/Minor	Minor1	Major1	Major2
Conflicting Flow All	1008	493	0
Stage 1	493	-	-
Stage 2	515	-	-
Critical Hdwy	6.58	6.26	-
Critical Hdwy Stg 1	5.58	-	-
Critical Hdwy Stg 2	5.58	-	-
Follow-up Hdwy	3.662	3.354	-
Pot Cap-1 Maneuver	249	568	-
Stage 1	582	-	-
Stage 2	568	-	-
Platoon blocked, %		-	-
Mov Cap-1 Maneuver	245	568	-
Mov Cap-2 Maneuver	245	-	-
Stage 1	582	-	-
Stage 2	558	-	-

Approach	NW	NE	SW
HCM Control Delay, s	20.2	0	0.2
HCM LOS	C		

Minor Lane/Major Mvmt	NET	NERNWLn1	SWL	SWT
Capacity (veh/h)	-	-	298	1043
HCM Lane V/C Ratio	-	-	0.205	0.012
HCM Control Delay (s)	-	-	20.2	8.5
HCM Lane LOS	-	-	C	A
HCM 95th %tile Q(veh)	-	-	0.8	0

Intersection						
Int Delay, s/veh	1.7					
Movement	EBL	EBR	NBL	NBT	SBT	SBR
Lane Configurations						
Traffic Vol, veh/h	21	77	94	640	658	31
Future Vol, veh/h	21	77	94	640	658	31
Conflicting Peds, #/hr	1	0	1	0	0	1
Sign Control	Stop	Stop	Free	Free	Free	Free
RT Channelized	-	None	-	None	-	None
Storage Length	125	0	0	-	-	-
Veh in Median Storage, #	0	-	-	0	0	-
Grade, %	0	-	-	0	0	-
Peak Hour Factor	92	92	92	92	92	92
Heavy Vehicles, %	5	5	6	6	3	3
Mvmt Flow	23	84	102	696	715	34

Major/Minor	Minor2	Major1	Major2			
Conflicting Flow All	1286	375	750	0	-	0
Stage 1	733	-	-	-	-	-
Stage 2	553	-	-	-	-	-
Critical Hdwy	6.9	7	4.22	-	-	-
Critical Hdwy Stg 1	5.9	-	-	-	-	-
Critical Hdwy Stg 2	5.9	-	-	-	-	-
Follow-up Hdwy	3.55	3.35	2.26	-	-	-
Pot Cap-1 Maneuver	152	614	829	-	-	-
Stage 1	428	-	-	-	-	-
Stage 2	532	-	-	-	-	-
Platoon blocked, %				-	-	-
Mov Cap-1 Maneuver	133	613	829	-	-	-
Mov Cap-2 Maneuver	133	-	-	-	-	-
Stage 1	428	-	-	-	-	-
Stage 2	466	-	-	-	-	-

Approach	EB	NB	SB
HCM Control Delay, s	17.3	1.3	0
HCM LOS	C		

Minor Lane/Major Mvmt	NBL	NBT	EBLn1	EBLn2	SBT	SBR
Capacity (veh/h)	829	-	133	613	-	-
HCM Lane V/C Ratio	0.123	-	0.172	0.137	-	-
HCM Control Delay (s)	10	-	37.6	11.8	-	-
HCM Lane LOS	A	-	E	B	-	-
HCM 95th %tile Q(veh)	0.4	-	0.6	0.5	-	-

Intersection												
Int Delay, s/veh	0.8											
Movement	EBL	EBT	EBR	WBL	WBT	WBR	NBL	NBT	NBR	SBL	SBT	SBR
Lane Configurations	↖	↗			↕			↕		↖	↗	
Traffic Vol, veh/h	2	530	2	6	791	7	8	0	23	7	0	1
Future Vol, veh/h	2	530	2	6	791	7	8	0	23	7	0	1
Conflicting Peds, #/hr	0	0	0	0	0	0	0	0	0	0	0	0
Sign Control	Free	Free	Free	Free	Free	Free	Stop	Stop	Stop	Stop	Stop	Stop
RT Channelized	-	-	None	-	-	None	-	-	None	-	-	None
Storage Length	125	-	-	-	-	-	-	-	-	75	-	-
Veh in Median Storage, #	-	0	-	-	0	-	-	0	-	-	0	-
Grade, %	-	0	-	-	0	-	-	0	-	-	0	-
Peak Hour Factor	95	95	90	90	95	95	90	90	90	95	90	95
Heavy Vehicles, %	2	2	2	2	2	2	2	2	2	28	2	2
Mvmt Flow	2	558	2	7	833	7	9	0	26	7	0	1

Major/Minor	Major1			Major2			Minor1			Minor2		
Conflicting Flow All	840	0	0	560	0	0	1413	1416	559	1426	1414	836
Stage 1	-	-	-	-	-	-	563	563	-	850	850	-
Stage 2	-	-	-	-	-	-	850	853	-	576	564	-
Critical Hdwy	4.12	-	-	4.12	-	-	7.12	6.52	6.22	7.38	6.52	6.22
Critical Hdwy Stg 1	-	-	-	-	-	-	6.12	5.52	-	6.38	5.52	-
Critical Hdwy Stg 2	-	-	-	-	-	-	6.12	5.52	-	6.38	5.52	-
Follow-up Hdwy	2.218	-	-	2.218	-	-	3.518	4.018	3.318	3.752	4.018	3.318
Pot Cap-1 Maneuver	795	-	-	1011	-	-	115	137	529	99	138	367
Stage 1	-	-	-	-	-	-	511	509	-	321	377	-
Stage 2	-	-	-	-	-	-	355	376	-	460	508	-
Platoon blocked, %	-	-	-	-	-	-	-	-	-	-	-	-
Mov Cap-1 Maneuver	795	-	-	1011	-	-	113	135	529	93	136	367
Mov Cap-2 Maneuver	-	-	-	-	-	-	113	135	-	93	136	-
Stage 1	-	-	-	-	-	-	510	508	-	320	372	-
Stage 2	-	-	-	-	-	-	349	371	-	437	507	-

Approach	EB			WB			NB			SB		
HCM Control Delay, s	0			0.1			20.2			43		
HCM LOS							C			E		

Minor Lane/Major Mvmt	NBLn1	EBL	EBT	EBR	WBL	WBT	WBR	SBLn1	SBLn2
Capacity (veh/h)	271	795	-	-	1011	-	-	93	367
HCM Lane V/C Ratio	0.127	0.003	-	-	0.007	-	-	0.079	0.003
HCM Control Delay (s)	20.2	9.5	-	-	8.6	0	-	47	14.8
HCM Lane LOS	C	A	-	-	A	A	-	E	B
HCM 95th %tile Q(veh)	0.4	0	-	-	0	-	-	0.3	0

Intersection

Int Delay, s/veh 1.5

Movement NBL NBR NET NER SWL SWT

Lane Configurations						
Traffic Vol, veh/h	8	113	558	2	29	806
Future Vol, veh/h	8	113	558	2	29	806
Conflicting Peds, #/hr	0	0	0	0	0	0
Sign Control	Stop	Stop	Free	Free	Free	Free
RT Channelized	-	None	-	None	-	None
Storage Length	50	0	-	-	-	-
Veh in Median Storage, #	0	-	0	-	-	0
Grade, %	0	-	0	-	-	0
Peak Hour Factor	90	90	90	90	90	90
Heavy Vehicles, %	2	2	2	2	2	2
Mvmt Flow	9	126	620	2	32	896

Major/Minor Minor1 Major1 Major2

Conflicting Flow All	1581	621	0	0	622	0
Stage 1	621	-	-	-	-	-
Stage 2	960	-	-	-	-	-
Critical Hdwy	6.42	6.22	-	-	4.12	-
Critical Hdwy Stg 1	5.42	-	-	-	-	-
Critical Hdwy Stg 2	5.42	-	-	-	-	-
Follow-up Hdwy	3.518	3.318	-	-	2.218	-
Pot Cap-1 Maneuver	120	487	-	-	959	-
Stage 1	536	-	-	-	-	-
Stage 2	372	-	-	-	-	-
Platoon blocked, %			-	-		
Mov Cap-1 Maneuver	112	487	-	-	959	-
Mov Cap-2 Maneuver	112	-	-	-	-	-
Stage 1	536	-	-	-	-	-
Stage 2	347	-	-	-	-	-

Approach NB NE SW

HCM Control Delay, s	16.6	0	0.3
HCM LOS	C		

Minor Lane/Major Mvmt NET NER NBLn1 NBLn2 SWL SWT

Capacity (veh/h)	-	-	112	487	959	-
HCM Lane V/C Ratio	-	-	0.079	0.258	0.034	-
HCM Control Delay (s)	-	-	39.9	14.9	8.9	0
HCM Lane LOS	-	-	E	B	A	A
HCM 95th %tile Q(veh)	-	-	0.3	1	0.1	-

HCM 2010 TWSC
 4: Estes Drive Extension & Airport Drive

12/13/2017

Intersection						
Int Delay, s/veh	13.7					
Movement	NWL	NWR	NET	NER	SWL	SWT
Lane Configurations						
Traffic Vol, veh/h	118	40	607	66	6	716
Future Vol, veh/h	118	40	607	66	6	716
Conflicting Peds, #/hr	0	0	0	0	0	0
Sign Control	Stop	Stop	Free	Free	Free	Free
RT Channelized	-	None	-	None	-	None
Storage Length	0	-	-	-	-	-
Veh in Median Storage, #	0	-	0	-	-	0
Grade, %	0	-	0	-	-	0
Peak Hour Factor	93	93	93	93	93	93
Heavy Vehicles, %	5	4	2	6	2	2
Mvmt Flow	127	43	653	71	6	770

Major/Minor	Minor1	Major1	Major2		
Conflicting Flow All	1471	688	0	0	724
Stage 1	688	-	-	-	-
Stage 2	783	-	-	-	-
Critical Hdwy	6.45	6.24	-	-	4.12
Critical Hdwy Stg 1	5.45	-	-	-	-
Critical Hdwy Stg 2	5.45	-	-	-	-
Follow-up Hdwy	3.545	3.336	-	-	2.218
Pot Cap-1 Maneuver	138	443	-	-	879
Stage 1	493	-	-	-	-
Stage 2	445	-	-	-	-
Platoon blocked, %					
Mov Cap-1 Maneuver	136	443	-	-	879
Mov Cap-2 Maneuver	136	-	-	-	-
Stage 1	493	-	-	-	-
Stage 2	440	-	-	-	-

Approach	NW	NE	SW
HCM Control Delay, s	134.3	0	0.1
HCM LOS	F		

Minor Lane/Major Mvmt	NET	NERNWLn1	SWL	SWT
Capacity (veh/h)	-	-	165	879
HCM Lane V/C Ratio	-	-	1.03	0.007
HCM Control Delay (s)	-	-	134.3	9.1
HCM Lane LOS	-	-	F	A
HCM 95th %tile Q(veh)	-	-	8.3	0

Intersection						
Int Delay, s/veh	2.3					
Movement	EBL	EBR	NBL	NBT	SBT	SBR
Lane Configurations						
Traffic Vol, veh/h	37	76	53	1302	853	6
Future Vol, veh/h	37	76	53	1302	853	6
Conflicting Peds, #/hr	4	0	2	0	0	2
Sign Control	Stop	Stop	Free	Free	Free	Free
RT Channelized	-	None	-	None	-	None
Storage Length	125	0	0	-	-	-
Veh in Median Storage, #	0	-	-	0	0	-
Grade, %	0	-	-	0	0	-
Peak Hour Factor	94	94	94	94	94	94
Heavy Vehicles, %	6	6	7	2	2	2
Mvmt Flow	39	81	56	1385	907	6

Major/Minor	Minor2	Major1	Major2			
Conflicting Flow All	1722	459	916	0	-	0
Stage 1	913	-	-	-	-	-
Stage 2	809	-	-	-	-	-
Critical Hdwy	6.92	7.02	4.24	-	-	-
Critical Hdwy Stg 1	5.92	-	-	-	-	-
Critical Hdwy Stg 2	5.92	-	-	-	-	-
Follow-up Hdwy	3.56	3.36	2.27	-	-	-
Pot Cap-1 Maneuver	77	538	710	-	-	-
Stage 1	342	-	-	-	-	-
Stage 2	388	-	-	-	-	-
Platoon blocked, %				-	-	-
Mov Cap-1 Maneuver	71	537	710	-	-	-
Mov Cap-2 Maneuver	71	-	-	-	-	-
Stage 1	341	-	-	-	-	-
Stage 2	357	-	-	-	-	-

Approach	EB	NB	SB
HCM Control Delay, s	43.4	0.4	0
HCM LOS	E		

Minor Lane/Major Mvmt	NBL	NBT	EBLn1	EBLn2	SBT	SBR
Capacity (veh/h)	710	-	71	537	-	-
HCM Lane V/C Ratio	0.079	-	0.554	0.151	-	-
HCM Control Delay (s)	10.5	-	106.1	12.9	-	-
HCM Lane LOS	B	-	F	B	-	-
HCM 95th %tile Q(veh)	0.3	-	2.3	0.5	-	-

Appendix G – Signal Warrant Analysis

Warrants Summary												
Information												
Analyst	CRS					Intersection	Estes Dr Ext & Airport Dr					
Agency/Co	HNTB North Carolina, PC					Jurisdiction	Chapel Hill, NC					
Date Performed	12/21/2017					Units	U.S. Customary					
Project ID	CH Municipal Services Campus					Time Period Analyzed	2021 With Site Scenario					
East/West Street	Estes Drive Extension					North/South Street	Airport Dr					
File Name	Estes & Airport.xhy					Major Street	East-West					
Project Description <i>CH Municipal Services Campus</i>												
General						Roadway Network						
Major Street Speed (mph)	35	<input type="checkbox"/>	Population < 10,000				Two Major Routes			<input type="checkbox"/>		
Nearest Signal (ft)	0	<input type="checkbox"/>	Coordinated Signal System				Weekend Count			<input type="checkbox"/>		
Crashes (per year)	0	<input type="checkbox"/>	Adequate Trials of Alternatives				5-yr Growth Factor			0		
Geometry and Traffic	EB			WB			NB			SB		
	LT	TH	RT	LT	TH	RT	LT	TH	RT	LT	TH	RT
Number of lanes, N	0	1	0	0	1	0	0	0	0	0	0	0
Lane usage	TR			LT			LR					
Vehicle Volume Averages (vph)	0	152	18	2	133	0	17	0	6	0	0	0
Peds (ped/h) / Gaps (gaps/h)	--	0 / 0	--	--	0 / 0	--	--	0 / 0	--	--	0 / 0	--
Delay (s/veh) / (veh-hr)	--	0 / 0	--	--	0.0 / 0	--	--	16.4 / 0.6	--	--	0 / 0	--
Warrant 1: Eight-Hour Vehicular Volume												<input type="checkbox"/>
1 A. Minimum Vehicular Volumes (Both major approaches --and-- higher minor approach) --or--												<input type="checkbox"/>
1 B. Interruption of Continuous Traffic (Both major approaches --and-- higher minor approach) --or--												<input type="checkbox"/>
1 (80%) Vehicular --and-- Interruption Volumes (Both major approaches --and-- higher minor approach)												<input type="checkbox"/>
Warrant 2: Four-Hour Vehicular Volume												<input type="checkbox"/>
2 A. Four-Hour Vehicular Volumes (Both major approaches --and-- higher minor approach)												<input type="checkbox"/>
Warrant 3: Peak Hour												<input checked="" type="checkbox"/>
3 A. Peak-Hour Conditions (Minor delay --and-- minor volume --and-- total volume) --or--												<input checked="" type="checkbox"/>
3 B. Peak- Hour Vehicular Volumes (Both major approaches --and-- higher minor approach)												<input checked="" type="checkbox"/>
Warrant 4: Pedestrian Volume												<input type="checkbox"/>
4 A. Four Hour Volumes --or--												<input type="checkbox"/>
4 B. One-Hour Volumes												<input type="checkbox"/>
Warrant 5: School Crossing												<input type="checkbox"/>
5. Student Volumes --and--												<input type="checkbox"/>
5. Gaps Same Period												<input type="checkbox"/>
Warrant 6: Coordinated Signal System												<input type="checkbox"/>
6. Degree of Platooning (Predominant direction or both directions)												<input type="checkbox"/>
Warrant 7: Crash Experience												<input type="checkbox"/>
7 A. Adequate trials of alternatives, observance and enforcement failed --and--												<input type="checkbox"/>
7 B. Reported crashes susceptible to correction by signal (12-month period) --and--												<input type="checkbox"/>

7 C. (80%) Volumes for Warrants 1A, 1B --or-- 4 are satisfied	<input type="checkbox"/>
Warrant 8: Roadway Network	<input type="checkbox"/>
8 A. Weekday Volume (Peak hour total --and-- projected warrants 1, 2 or 3) --or--	<input type="checkbox"/>
8 B. Weekend Volume (Five hours total)	<input type="checkbox"/>
Warrant 9: Grade Crossing	<input type="checkbox"/>
9 A. Grade Crossing within 140 ft --and--	<input type="checkbox"/>
9 B. Peak-Hour Vehicular Volumes	<input type="checkbox"/>

Warrants Volume

Information			
Analyst	CRS	Intersection	Estes Dr Ext & Airport Dr
Agency/Co	HNTB North Carolina, PC	Jurisdiction	Chapel Hill, NC
Date Performed	12/21/2017	Units	U.S. Customary
Project ID	CH Municipal Services Campus	Time Period Analyzed	2021 With Site Scenario
East/West Street	Estes Drive Extension	North/South Street	Airport Dr
File Name	Estes & Airport.xhy	Major Street	East-West

Project Description *CH Municipal Services Campus*

Warrant 1

Condition A—Minimum Vehicular Volume										Condition B—Interruption of Continuous Traffic									
Number of lanes for moving traffic on each approach		Vehicles per hour on major street (total of both approaches)				Vehicles per hour on higher-volume minor-street approach (one direction only)				Number of lanes for moving traffic on each approach		Vehicles per hour on major street (total of both approaches)				Vehicles per hour on higher-volume minor-street approach (one direction only)			
Major Street	Minor Street	100%	80%	70%	56%	100%	80%	70%	56%	Major Street	Minor Street	100%	80%	70%	56%	100%	80%	70%	56%
1	1	500	400	350	280	150	120	106	84	1	1	750	600	525	420	75	60	53	42
2 or more	1	600	480	420	336	150	120	106	84	2 or more	1	900	720	630	504	75	60	53	42
2 or more	2 or more	600	480	420	336	200	160	140	112	2 or more	2 or more	900	720	630	504	100	80	70	56
1	2 or more	500	400	350	280	200	160	140	112	1	2 or more	750	600	525	420	100	80	70	56

Warrant 2

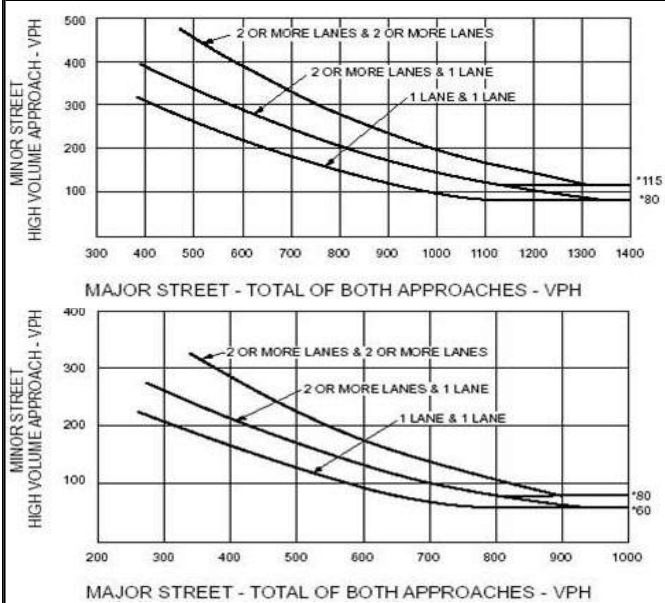

Warrant 3

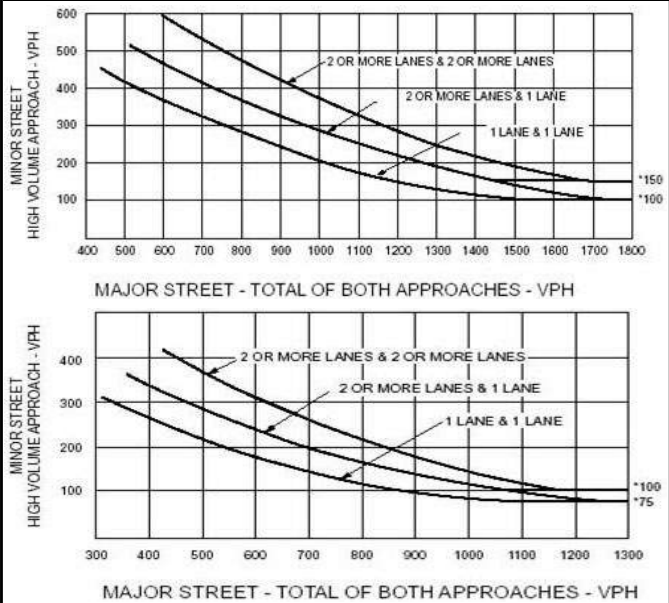

Volume Summary

Major Street Lanes 1			Minor Street Lanes 1			Speed		Population		
Hours	Major Volume	Minor Volume	Total Volume	1A (100%)	1A (80%)	1B (100%)	1B (80%)	2 (100%)	3A (100%)	3B (100%)
07-08	1316	73	1389	No	No	No	Yes	No	No	No
08-09	0	0	0	No	No	No	No	No	No	No
09-10	0	0	0	No	No	No	No	No	No	No
10-11	0	0	0	No	No	No	No	No	No	No
11-12	0	0	0	No	No	No	No	No	No	No
12-13	974	58	1032	No	No	No	No	No	No	No
13-14	0	0	0	No	No	No	No	No	No	No
14-15	0	0	0	No	No	No	No	No	No	No
15-16	0	0	0	No	No	No	No	No	No	No
16-17	0	0	0	No	No	No	No	No	No	No
17-18	1395	158	1553	Yes	Yes	Yes	Yes	Yes	Yes	Yes
18-19	0	0	0	No	No	No	No	No	No	No
Totals	3685	289	3974	1	1	1	2	1	1	1

Warrants Summary												
Information												
Analyst	CRS					Intersection	NC 86 & Airport Dr					
Agency/Co	HNTB North Carolina, PC					Jurisdiction	Chapel Hill, NC					
Date Performed	12/21/2017					Units	U.S. Customary					
Project ID	CH Municipal Services Campus					Time Period Analyzed	2021 With Site Scenario					
East/West Street	Airport Drive					North/South Street	NC 86 (MLK Jr Blvd)					
File Name	NC 86 & Airport.xhy					Major Street	North-South					
Project Description <i>CH Municipal Services Campus</i>												
General						Roadway Network						
Major Street Speed (mph)	35	<input type="checkbox"/>	Population < 10,000				Two Major Routes			<input type="checkbox"/>		
Nearest Signal (ft)	0	<input type="checkbox"/>	Coordinated Signal System				Weekend Count			<input type="checkbox"/>		
Crashes (per year)	0	<input type="checkbox"/>	Adequate Trials of Alternatives				5-yr Growth Factor			0		
Geometry and Traffic	EB			WB			NB			SB		
	LT	TH	RT	LT	TH	RT	LT	TH	RT	LT	TH	RT
Number of lanes, N	1	0	1	0	0	0	1	2	0	0	2	0
Lane usage	L		R				L	T			TR	
Vehicle Volume Averages (vph)	5	0	21	0	0	0	21	210	0	0	219	14
Peds (ped/h) / Gaps (gaps/h)	--	0 / 0	--	--	0 / 0	--	--	0 / 0	--	--	0 / 0	--
Delay (s/veh) / (veh-hr)	--	6.7 / 0.2	--	--	0 / 0	--	--	0.3 / 0.1	--	--	0 / 0	--
Warrant 1: Eight-Hour Vehicular Volume												<input type="checkbox"/>
1 A. Minimum Vehicular Volumes (Both major approaches --and-- higher minor approach) --or--												<input type="checkbox"/>
1 B. Interruption of Continuous Traffic (Both major approaches --and-- higher minor approach) --or--												<input type="checkbox"/>
1 (80%) Vehicular --and-- Interruption Volumes (Both major approaches --and-- higher minor approach)												<input type="checkbox"/>
Warrant 2: Four-Hour Vehicular Volume												<input type="checkbox"/>
2 A. Four-Hour Vehicular Volumes (Both major approaches --and-- higher minor approach)												<input type="checkbox"/>
Warrant 3: Peak Hour												<input type="checkbox"/>
3 A. Peak-Hour Conditions (Minor delay --and-- minor volume --and-- total volume) --or--												<input type="checkbox"/>
3 B. Peak- Hour Vehicular Volumes (Both major approaches --and-- higher minor approach)												<input type="checkbox"/>
Warrant 4: Pedestrian Volume												<input type="checkbox"/>
4 A. Four Hour Volumes --or--												<input type="checkbox"/>
4 B. One-Hour Volumes												<input type="checkbox"/>
Warrant 5: School Crossing												<input type="checkbox"/>
5. Student Volumes --and--												<input type="checkbox"/>
5. Gaps Same Period												<input type="checkbox"/>
Warrant 6: Coordinated Signal System												<input type="checkbox"/>
6. Degree of Platooning (Predominant direction or both directions)												<input type="checkbox"/>
Warrant 7: Crash Experience												<input type="checkbox"/>
7 A. Adequate trials of alternatives, observance and enforcement failed --and--												<input type="checkbox"/>
7 B. Reported crashes susceptible to correction by signal (12-month period) --and--												<input type="checkbox"/>

7 C. (80%) Volumes for Warrants 1A, 1B --or-- 4 are satisfied	<input type="checkbox"/>
Warrant 8: Roadway Network	<input type="checkbox"/>
8 A. Weekday Volume (Peak hour total --and-- projected warrants 1, 2 or 3) --or--	<input type="checkbox"/>
8 B. Weekend Volume (Five hours total)	<input type="checkbox"/>
Warrant 9: Grade Crossing	<input type="checkbox"/>
9 A. Grade Crossing within 140 ft --and--	<input type="checkbox"/>
9 B. Peak-Hour Vehicular Volumes	<input type="checkbox"/>

Warrants Volume

Information

Analyst: CRS Agency/Co: HNTB North Carolina, PC Date Performed: 12/21/2017 Project ID: CH Municipal Services Campus East/West Street: Airport Drive File Name: NC 86 & Airport.xhy	Intersection: NC 86 & Airport Dr Jurisdiction: Chapel Hill, NC Units: U.S. Customary Time Period Analyzed: 2021 With Site Scenario North/South Street: NC 86 (MLK Jr Blvd) Major Street: North-South
---	---

Project Description *CH Municipal Services Campus*

Warrant 1

Condition A—Minimum Vehicular Volume

Number of lanes for moving traffic on each approach		Vehicles per hour on major street (total of both approaches)				Vehicles per hour on higher-volume minor-street approach (one direction only)			
		100%	80%	70%	56%	100%	80%	70%	56%
Major Street	Minor Street								
1	1	500	400	350	280	150	120	105	84
2 or more	1	600	480	420	336	150	120	105	84
2 or more	2 or more	600	480	420	336	200	160	140	112
1	2 or more	500	400	350	280	200	160	140	112

Condition B—Interruption of Continuous Traffic

Number of lanes for moving traffic on each approach		Vehicles per hour on major street (total of both approaches)				Vehicles per hour on higher-volume minor-street approach (one direction only)			
		100%	80%	70%	56%	100%	80%	70%	56%
Major Street	Minor Street								
1	1	750	600	525	420	75	60	53	42
2 or more	1	900	720	630	504	75	60	53	42
2 or more	2 or more	900	720	630	504	100	80	70	56
1	2 or more	750	600	525	420	100	80	70	56

Warrant 2

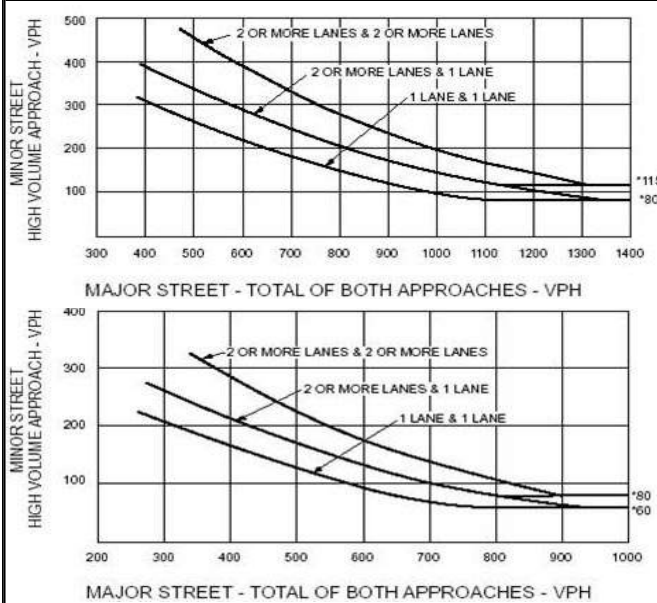

Warrant 3

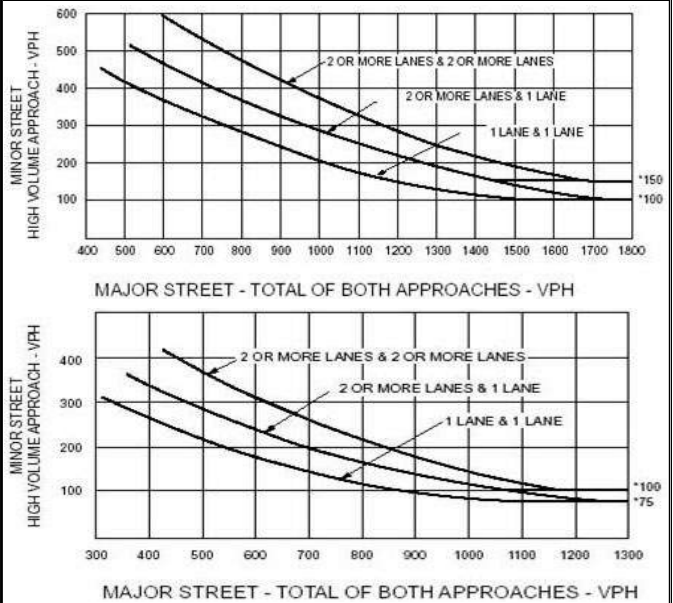

Volume Summary

Hours	Major Street Lanes 2+			Minor Street Lanes 2+		Speed		Population		
	Major Volume	Minor Volume	Total Volume	1A (100%)	1A (80%)	1B (100%)	1B (80%)	2 (100%)	3A (100%)	3B (100%)
07-08	1948	102	2050	No	No	Yes	Yes	No	No	No
08-09	0	0	0	No	No	No	No	No	No	No
09-10	0	0	0	No	No	No	No	No	No	No
10-11	0	0	0	No	No	No	No	No	No	No
11-12	0	0	0	No	No	No	No	No	No	No
12-13	1423	98	1521	No	No	No	Yes	No	No	No
13-14	0	0	0	No	No	No	No	No	No	No
14-15	0	0	0	No	No	No	No	No	No	No
15-16	0	0	0	No	No	No	No	No	No	No
16-17	0	0	0	No	No	No	No	No	No	No
17-18	2214	113	2327	No	No	Yes	Yes	No	No	No
18-19	0	0	0	No	No	No	No	No	No	No
Totals	5585	313	5898	0	0	2	3	0	0	0

Appendix H – Crash Data

**North Carolina Department of Transportation
Traffic Engineering Accident Analysis System
Strip Analysis Report**

Study Criteria Summary

County: ORANGE **City:** All and Rural
Date: 11/1/2012 **to** 10/31/2017 **Study:** ESTESDREXTSTRIP
Location: SR 1780 (Estes Dr Ext) from SR 1843 (Seawell School Rd) to NC 86 (Martin Luther King Jr. Blvd)

Report Details

Acc No	Crash ID	Milepost	Date	Accident Type	Total Damage	Injuries				Condition			Road		Trfc Ctl	
						F	A	B	C	R	L	W	Ch	Ci	Dv	Op
1	103707110	0.950	03/13/2013 08:15	RAN OFF ROAD - RIGHT	\$ 1500	0	0	0	0	1	1	1	1	0	3	1
Unit	1 : 1	Alchl/Drgs:	0	Speed:	35 MPH Dir: N	Veh Mnvr/Ped Actn:				8	Obj Strk:		42			

2	104012507	0.950	03/01/2014 06:35	RAN OFF ROAD - RIGHT	\$ 3000	1	0	0	0	1	3	2	7	0	13	1
Unit	1 : 20	Alchl/Drgs:	1	Speed:	55 MPH Dir: SW	Veh Mnvr/Ped Actn:				4	Obj Strk:		64			

3	103632486	0.964	12/06/2012 17:20	ANIMAL	\$ 2000	0	0	0	0	1	5	2	3	0	0	
Unit	1 : 1	Alchl/Drgs:	0	Speed:	35 MPH Dir: E	Veh Mnvr/Ped Actn:				4	Obj Strk:		17			

4	104364723	1.070	04/28/2015 19:15	ANIMAL	\$ 500	0	0	0	0	1	1	1	7	0	13	2
Unit	1 : 1	Alchl/Drgs:	0	Speed:	35 MPH Dir: N	Veh Mnvr/Ped Actn:				4	Obj Strk:		17			

5	103714748	1.250	03/24/2013 18:31	RAN OFF ROAD - LEFT	\$ 8000	0	0	0	0	2	4	2	5	0		
Unit	1 : 1	Alchl/Drgs:	1	Speed:	35 MPH Dir: E	Veh Mnvr/Ped Actn:				4	Obj Strk:		58			

6	103954240	1.461	12/15/2013 17:38	ANIMAL	\$ 1000	0	0	0	0	1	4	1	1	0	0	
Unit	1 : 1	Alchl/Drgs:	0	Speed:	30 MPH Dir: S	Veh Mnvr/Ped Actn:				4	Obj Strk:		17			

7	103998877	1.467	01/21/2014 16:57	RAN OFF ROAD - RIGHT	\$ 8000	0	0	0	0	1	2	2	3	0	0	2
Unit	1 : 2	Alchl/Drgs:	0	Speed:	45 MPH Dir: E	Veh Mnvr/Ped Actn:				4	Obj Strk:		34			

8	103628509	1.476	12/10/2012 07:03	REAR END, SLOW OR STOP	\$ 4400	0	0	0	1	2	1	2	1	1		
Unit	1 : 1	Alchl/Drgs:	0	Speed:	45 MPH Dir: W	Veh Mnvr/Ped Actn:				4	Obj Strk:					
Unit	2 : 1	Alchl/Drgs:	0	Speed:	0 MPH Dir: W	Veh Mnvr/Ped Actn:				11	Obj Strk:					

9	104599113	1.500	12/14/2015 20:37	RAN OFF ROAD - RIGHT	\$ 4000	0	0	1	0	1	4	1	3	0	13	1
Unit	1 : 1	Alchl/Drgs:	0	Speed:	50 MPH Dir: W	Veh Mnvr/Ped Actn:				4	Obj Strk:		33			

10	104685929	1.677	03/17/2016 07:54	REAR END, SLOW OR STOP	\$ 2800	0	0	0	0	1	1	1	3	0	3	1
Unit	1 : 2	Alchl/Drgs:	0	Speed:	30 MPH Dir: E	Veh Mnvr/Ped Actn:				1	Obj Strk:					

**North Carolina Department of Transportation
Traffic Engineering Accident Analysis System
Strip Analysis Report**

Acc No	Crash ID	Milepost	Date	Accident Type	Total Damage	Injuries				Condition			Road		Trfc Ctl	
						F	A	B	C	R	L	W	Ch	Ci	Dv	Op
Unit	2 : 1	Alchl/Drgs:	0	Speed:	30 MPH	Dir:	E	Veh Mnvr/Ped Actn:				4	Obj Strk:			
11	104977435	1.692	12/19/2016 20:43	RAN OFF ROAD - LEFT	\$ 10000	0	0	1	0	1	4	1	5	0	0	
Unit	1 : 2	Alchl/Drgs:	0	Speed:	40 MPH	Dir:	S	Veh Mnvr/Ped Actn:				4	Obj Strk: 17			
12	104924595	1.724	10/24/2016 14:53	REAR END, SLOW OR STOP	\$ 1000	0	0	0	0	1	1	1	1	0	3	1
Unit	1 : 1	Alchl/Drgs:	1	Speed:	0 MPH	Dir:	E	Veh Mnvr/Ped Actn:				11	Obj Strk:			
Unit	2 : 4	Alchl/Drgs:	0	Speed:	0 MPH	Dir:	E	Veh Mnvr/Ped Actn:				11	Obj Strk:			
13	103647661	1.730	12/20/2012 22:43	OTHER COLLISION WITH VEHICLE	\$ 10000	0	0	0	3	2	4	3	1	7	3	2
Unit	1 : 1	Alchl/Drgs:	0	Speed:	10 MPH	Dir:	W	Veh Mnvr/Ped Actn:				4	Obj Strk:			
Unit	2 : 1	Alchl/Drgs:	0	Speed:	35 MPH	Dir:	S	Veh Mnvr/Ped Actn:				4	Obj Strk:			
14	103654207	1.730	12/21/2012 17:20	REAR END, SLOW OR STOP	\$ 2000	0	0	0	0	2	1	3	1	0	3	1
Unit	1 : 7	Alchl/Drgs:	0	Speed:	5 MPH	Dir:	E	Veh Mnvr/Ped Actn:				4	Obj Strk:			
Unit	2 : 1	Alchl/Drgs:	0	Speed:	0 MPH	Dir:	E	Veh Mnvr/Ped Actn:				11	Obj Strk:			
15	103659727	1.730	01/01/2013 17:26	LEFT TURN, DIFFERENT ROADWAYS	\$ 2500	0	0	0	1	2	2	3	1	0	3	1
Unit	1 : 4	Alchl/Drgs:	0	Speed:	35 MPH	Dir:	NE	Veh Mnvr/Ped Actn:				8	Obj Strk:			
Unit	2 : 1	Alchl/Drgs:	0	Speed:	0 MPH	Dir:	S	Veh Mnvr/Ped Actn:				1	Obj Strk:			
Unit	3 : 4	Alchl/Drgs:	0	Speed:	15 MPH	Dir:	SE	Veh Mnvr/Ped Actn:				8	Obj Strk:			
16	103678294	1.730	02/08/2013 12:12	LEFT TURN, SAME ROADWAY	\$ 10000	0	0	0	0	1	1	2	1	0	3	1
Unit	1 : 1	Alchl/Drgs:	0	Speed:	20 MPH	Dir:	E	Veh Mnvr/Ped Actn:				4	Obj Strk:			
Unit	2 : 1	Alchl/Drgs:	0	Speed:	20 MPH	Dir:	W	Veh Mnvr/Ped Actn:				8	Obj Strk:			
17	103761905	1.730	05/20/2013 15:56	LEFT TURN, SAME ROADWAY	\$ 8500	0	0	1	0	2	1	3	3	0	3	1
Unit	1 : 1	Alchl/Drgs:	0	Speed:	30 MPH	Dir:	S	Veh Mnvr/Ped Actn:				4	Obj Strk:			
Unit	2 : 1	Alchl/Drgs:	0	Speed:	15 MPH	Dir:	S	Veh Mnvr/Ped Actn:				8	Obj Strk:			
18	103787091	1.730	06/16/2013 18:23	LEFT TURN, SAME ROADWAY	\$ 6000	0	0	0	0	1	1	1	1	0	3	1
Unit	1 : 2	Alchl/Drgs:	0	Speed:	35 MPH	Dir:	S	Veh Mnvr/Ped Actn:				4	Obj Strk:			
Unit	2 : 17	Alchl/Drgs:	0	Speed:	15 MPH	Dir:	E	Veh Mnvr/Ped Actn:				8	Obj Strk:			
19	103892317	1.730	10/21/2013 19:13	SIDESWIPE, OPPOSITE DIRECTION	\$ 3500	0	0	0	0	1	2	1	1	0	3	1
Unit	1 : 1	Alchl/Drgs:	0	Speed:	10 MPH	Dir:	W	Veh Mnvr/Ped Actn:				8	Obj Strk:			
Unit	2 : 1	Alchl/Drgs:	0	Speed:	25 MPH	Dir:	E	Veh Mnvr/Ped Actn:				4	Obj Strk:			

**North Carolina Department of Transportation
Traffic Engineering Accident Analysis System
Strip Analysis Report**

Acc No	Crash ID	Milepost	Date	Accident Type	Total Damage	Injuries				Condition			Road		Trfc Ctl	
						F	A	B	C	R	L	W	Ch	Ci	Dv	Op
20	103961747	1.730	12/09/2013 18:08	SIDESWIPE, SAME DIRECTION	\$ 1800	0	0	0	0	2	4	3	1	0	3	2
Unit	1 : 1	Alchl/Drugs:	0	Speed: 20 MPH Dir: N		Veh Mnvr/Ped Actn:				7	Obj Strk:					
Unit	2 : 4	Alchl/Drugs:	0	Speed: 20 MPH Dir: N		Veh Mnvr/Ped Actn:				8	Obj Strk:					

21	104005855	1.730	02/01/2014 12:32	LEFT TURN, DIFFERENT ROADWAYS	\$ 7000	0	0	0	0	1	1	2	1	0	3	1
Unit	1 : 1	Alchl/Drugs:	0	Speed: 35 MPH Dir: W		Veh Mnvr/Ped Actn:				4	Obj Strk:					
Unit	2 : 1	Alchl/Drugs:	0	Speed: 15 MPH Dir: E		Veh Mnvr/Ped Actn:				8	Obj Strk:					

22	104002496	1.730	02/14/2014 14:52	RIGHT TURN, DIFFERENT ROADWAYS	\$ 1550	0	0	0	0	1	1	1	1	0	3	1
Unit	1 : 1	Alchl/Drugs:	0	Speed: 30 MPH Dir: S		Veh Mnvr/Ped Actn:				4	Obj Strk:					
Unit	2 : 1	Alchl/Drugs:	0	Speed: 10 MPH Dir: E		Veh Mnvr/Ped Actn:				7	Obj Strk:					

23	104068211	1.730	05/16/2014 15:42	ANGLE	\$ 2800	0	0	0	0	1	1	1	1	0	3	1
Unit	1 : 1	Alchl/Drugs:	0	Speed: 5 MPH Dir: SE		Veh Mnvr/Ped Actn:				8	Obj Strk:					
Unit	2 : 2	Alchl/Drugs:	0	Speed: 15 MPH Dir: N		Veh Mnvr/Ped Actn:				4	Obj Strk:					

24	104582812	1.730	11/22/2015 01:42	ANGLE	\$ 12000	0	0	0	0	1	4	1	1	0	3	1
Unit	1 : 4	Alchl/Drugs:	0	Speed: 40 MPH Dir: S		Veh Mnvr/Ped Actn:				4	Obj Strk:					
Unit	2 : 5	Alchl/Drugs:	0	Speed: 10 MPH Dir: E		Veh Mnvr/Ped Actn:				8	Obj Strk:					

25	105064389	1.730	04/03/2017 20:46	LEFT TURN, SAME ROADWAY	\$ 6700	0	0	0	0	2	4	2	3	0	3	1
Unit	1 : 4	Alchl/Drugs:	0	Speed: 30 MPH Dir: W		Veh Mnvr/Ped Actn:				4	Obj Strk:					
Unit	2 : 1	Alchl/Drugs:	0	Speed: 30 MPH Dir: E		Veh Mnvr/Ped Actn:				8	Obj Strk:					
Unit	3 : 4	Alchl/Drugs:	0	Speed: 35 MPH Dir: S		Veh Mnvr/Ped Actn:				1	Obj Strk:					

Legend for Report Details:
 Acc No - Accident Number
 Injuries: F - Fatal, A - Class A, B - Class B, C - Class C
 Condition: R - Road Surface, L - Ambient Light, W - Weather
 Rd Ch - Road Character
 Rd Ci - Roadway Contributing Circumstances
 Trfc Ctl - Traffic Control: Dv - Device, Op - Operating
 Alchl/Drugs - Alcohol Drugs Suspected
 Veh Mnvr/Ped Actn - Vehicle Maneuver/Pedestrian Action
 Obj Strk - Object Struck

**North Carolina Department of Transportation
Traffic Engineering Accident Analysis System
Strip Analysis Report**

Summary Statistics

High Level Crash Summary

Crash Type	Number of Crashes	Percent of Total
Total Crashes	25	100.00
Fatal Crashes	1	4.00
Non-Fatal Injury Crashes	6	24.00
Total Injury Crashes	7	28.00
Property Damage Only Crashes	18	72.00
Night Crashes	9	36.00
Wet Crashes	8	32.00
Alcohol/Drugs Involvement Crashes	3	12.00

Crash Severity Summary

Crash Type	Number of Crashes	Percent of Total
Total Crashes	25	100.00
Fatal Crashes	1	4.00
Class A Crashes	0	0.00
Class B Crashes	3	12.00
Class C Crashes	3	12.00
Property Damage Only Crashes	18	72.00

Vehicle Exposure Statistics

Annual ADT = 12400

Total Length = 0.78 (Miles) 1.255 (Kilometers)

Total Vehicle Exposure = 17.66 (MVMT) 28.42 (MVKMT)

Crash Rate	Crashes Per 100 Million Vehicle Miles	Crashes Per 100 Million Vehicle Kilometers
Total Crash Rate	141.55	87.96
Fatal Crash Rate	5.66	3.52
Non Fatal Crash Rate	33.97	21.11
Night Crash Rate	50.96	31.66
Wet Crash Rate	45.30	28.15
EPDO Rate	822.15	510.86

**North Carolina Department of Transportation
Traffic Engineering Accident Analysis System
Strip Analysis Report**

Miscellaneous Statistics

Severity Index =	5.81
EPDO Crash Index =	145.20
Estimated Property Damage Total = \$	120550.00

Accident Type Summary

Accident Type	Number of Crashes	Percent of Total
ANGLE	2	8.00
ANIMAL	3	12.00
LEFT TURN, DIFFERENT ROADWAYS	2	8.00
LEFT TURN, SAME ROADWAY	4	16.00
OTHER COLLISION WITH VEHICLE	1	4.00
RAN OFF ROAD - LEFT	2	8.00
RAN OFF ROAD - RIGHT	4	16.00
REAR END, SLOW OR STOP	4	16.00
RIGHT TURN, DIFFERENT ROADWAYS	1	4.00
SIDESWIPE, OPPOSITE DIRECTION	1	4.00
SIDESWIPE, SAME DIRECTION	1	4.00

Injury Summary

Injury Type	Number of Injuries	Percent of Total
Fatal Injuries	1	11.11
Class A Injuries	0	0.00
Class B Injuries	3	33.33
Class C Injuries	5	55.56
Total Non-Fatal Injuries	8	88.89
Total Injuries	9	100.00

**North Carolina Department of Transportation
Traffic Engineering Accident Analysis System
Strip Analysis Report**

Monthly Summary

Month	Number of Crashes	Percent of Total
Jan	2	8.00
Feb	3	12.00
Mar	4	16.00
Apr	2	8.00
May	2	8.00
Jun	1	4.00
Jul	0	0.00
Aug	0	0.00
Sep	0	0.00
Oct	2	8.00
Nov	1	4.00
Dec	8	32.00

Daily Summary

Day	Number of Crashes	Percent of Total
Mon	8	32.00
Tue	3	12.00
Wed	1	4.00
Thu	3	12.00
Fri	4	16.00
Sat	2	8.00
Sun	4	16.00

**North Carolina Department of Transportation
Traffic Engineering Accident Analysis System
Strip Analysis Report**

Hourly Summary

Hour	Number of Crashes	Percent of Total
0000-0059	0	0.00
0100-0159	1	4.00
0200-0259	0	0.00
0300-0359	0	0.00
0400-0459	0	0.00
0500-0559	0	0.00
0600-0659	1	4.00
0700-0759	2	8.00
0800-0859	1	4.00
0900-0959	0	0.00
1000-1059	0	0.00
1100-1159	0	0.00
1200-1259	2	8.00
1300-1359	0	0.00
1400-1459	2	8.00
1500-1559	2	8.00
1600-1659	1	4.00
1700-1759	4	16.00
1800-1859	3	12.00
1900-1959	2	8.00
2000-2059	3	12.00
2100-2159	0	0.00
2200-2259	1	4.00
2300-2359	0	0.00

**North Carolina Department of Transportation
Traffic Engineering Accident Analysis System
Strip Analysis Report**

Light and Road Conditions Summary

Condition	Dry	Wet	Other	Total
Day	9	3	0	12
Dark	5	4	0	9
Other	3	1	0	4
Total	17	8	0	25

Object Struck Summary

Object Type	Times Struck	Percent of Total
ANIMAL	4	44.44
DITCH	1	11.11
GUARDRAIL FACE ON SHOULDER	1	11.11
OTHER FIXED OBJECT	1	11.11
TREE	1	11.11
UTILITY POLE	1	11.11

Vehicle Type Summary

Vehicle Type	Number Involved	Percent of Total
MOTORCYCLE	1	2.33
PASSENGER CAR	27	62.79
PICKUP	5	11.63
SCHOOL BUS	1	2.33
SPORT UTILITY	7	16.28
TAXICAB	1	2.33
VAN	1	2.33

North Carolina Department of Transportation
Traffic Engineering Accident Analysis System
Strip Analysis Report

Yearly Totals Summary

Accident Totals

Year	Total Accidents	Fatal Accidents	Injury Accidents	Property Damage Only Accidents
2012	4	0	2	2
2013	9	0	2	7
2014	5	1	0	4
2015	3	0	1	2
2016	3	0	1	2
2017	1	0	0	1
Total	25	1	6	18

Injury Totals

Year	Fatal Injuries	Class A, B, or C Injuries
2012	0	4
2013	0	2
2014	1	0
2015	0	1
2016	0	1
2017	0	0
Total	1	8

Miscellaneous Totals

Year	Property Damage	EPDO Index
2012	\$ 18400	18.80
2013	\$ 42800	23.80
2014	\$ 22350	80.80
2015	\$ 16500	10.40
2016	\$ 13800	10.40
2017	\$ 6700	1.00
Total	\$ 120550	145.20

Type of Accident Totals

Year	Left Turn	Right Turn	Rear End	Run Off Road &			
				Fixed Object	Angle	Side Swipe	Other
2012	0	0	2	0	0	0	2
2013	4	0	0	2	0	2	1
2014	1	1	0	2	1	0	0

**North Carolina Department of Transportation
Traffic Engineering Accident Analysis System
Strip Analysis Report**

Year	Left Turn	Right Turn	Rear End	Run Off Road & Fixed Object	Angle	Side Swipe	Other
2015	0	0	0	1	1	0	1
2016	0	0	2	1	0	0	0
2017	1	0	0	0	0	0	0
Total	6	1	4	6	2	2	4

**North Carolina Department of Transportation
Traffic Engineering Accident Analysis System
Strip Analysis Report**

Strip Diagram

Features	Milepost	Crash IDs
SR 1843 SEWELL SCHOOL	0.95	103707110 104012507
	0.96	103632486
	0.97	
	0.98	
	0.99	
	1.00	
	1.01	
	1.02	
	1.03	
	1.04	
	1.05	
	1.06	
	1.07	104364723
	1.08	
	1.09	
	1.10	
RR LOT ENTRANCE	1.11	
	1.12	
	1.13	
	1.14	
	1.15	
	1.16	
	1.17	
	1.18	
	1.19	
	1.20	
	1.21	
	1.22	
	1.23	
	1.24	
	1.25	103714748
	1.26	
	1.27	
	1.28	
	1.29	
	1.30	
	1.31	
	1.32	
	1.33	
	1.34	
	1.35	
	1.36	
	1.37	
	1.38	

**North Carolina Department of Transportation
Traffic Engineering Accident Analysis System
Strip Analysis Report**

Features	Milepost	Crash IDs
	1.39	
	1.40	
	1.41	
	1.42	
	1.43	
	1.44	
	1.45	
	1.46	103954240
AIRPORT	1.47	103998877
	1.48	103628509
	1.49	
	1.50	104599113
	1.51	
	1.52	
	1.53	
	1.54	
	1.55	
	1.56	
	1.57	
	1.58	
	1.59	
FACILITIES DR	1.60	
	1.61	
	1.62	
	1.63	
	1.64	
	1.65	
	1.66	
	1.67	
	1.68	104685929
	1.69	104977435
	1.70	
	1.71	
	1.72	104924595
NC 86 SR 1750 MARTIN LUTHER KING	1.73	103647661 103654207 103659727 103678294 103761905 103787091 103892317 103961747 104005855 104002496 104068211 104582812 105064389

**North Carolina Department of Transportation
Traffic Engineering Accident Analysis System
Strip Analysis Report**

Study Criteria

Study Name	Log No.	PH No.	TIP No.	K/A Cf.	B/C Cf.	ADT	ADT Route
ESTESDREXTSTRIP				76.8	8.4	12400	40001780

Request Date	Courier Service	Phone No.	Ext.	Fax No.

County			Municipality			Name	Code	Div.	Name	Code	Y-Line Ft.	Begin Date	End Date	Years
ORANGE							68	7	All and Rural		0	11/1/2012	10/31/2017	5.00

Location Text	Requestor
SR 1780 (Estes Dr Ext) from SR 1843 (Seawell School Rd) to NC 86 (Martin Luther King Jr. Blvd)	

Included Accidents	Old MP	New MP	Type
103998877	1.531	1.467	R
104977435	1.294	1.692	R

Excluded Accidents
103683324
103691001
103703630
103716916
103774745
103828029
103939566
104020946
104262198
104355424
104369919
104490927
104628361
104667241
104687062
104741442
104811851
105061198
105070133
105214438

**North Carolina Department of Transportation
Traffic Engineering Accident Analysis System
Strip Analysis Report**

Fiche Roads

Name	Code
SR 1780	40001780
ESTES DR EXT	50009903
SR 1750	40001750
HILLCREST	50014034

Strip Road

Name	Code	Begin MP	End MP	Miles	Kilometers
SR 1780	40001780	0.950	1.730	0.780	1.255
